

---

# ALGEMEEN

## INHOUDSOPGAVE

|   |         |
|---|---------|
| 1. MOTOR- EN TRANSMISSIEMODELLEN .....          | 00A-1-1 |
| 2. MOTORMODEL- EN SERIENUMMER .....             | 00A-2-1 |
| 3. VOORZORGSMAATREGELEN TIJDENS ONDERHOUD ..... | 00A-3-1 |
| 4. AANTREKKOPPELS .....                         | 00A-4-1 |

## 1. MOTOR- EN TRANSMISSIEMODELLEN

## 1990 modellen voor Europa

| Voertuig-model       | Voertuig-model-code | Motor         |          |          |                         |                  | Brandstof-systeem | Versnellingsbak    |              |                      |
|----------------------|---------------------|---------------|----------|----------|-------------------------|------------------|-------------------|--------------------|--------------|----------------------|
|                      |                     | Model (liter) | Balansas | Nokkenas | Hydraulische klepstoter | Turbo-compressor |                   | Model              | Type         | Vierwiel-aandrijving |
| Lancer station-wagon | C12V                | 4G15-1 (1,5)  | –        | Enkel    | –                       | –                | CARB              | F5M21-1<br>F3A21-2 | 5M/T<br>3A/T | –<br>–               |
|                      |                     |               |          |          |                         |                  | MPI               | F5M21-1<br>F3A21-2 | 5M/T<br>3A/T | –<br>–               |
|                      | C14V                | 4D65-1 (1,8)  | X        | Enkel    | –                       | –                | Diesel S-QGS      | F5M22-1            | 5M/T         | –                    |
|                      | C37V                | 4G37-8 (1,8)  | –        | Enkel    | –                       | –                | CARB              | W5M31-1            | 5M/T         | X                    |
| ELEC. CARB           |                     |               |          |          |                         |                  | W5M31-1           | 5M/T               | X            |                      |
| Colt                 | C51V                | 4G13-1 (1,3)  | –        | Enkel    | –                       | –                | CARB              | F4M21-1            | 4M/T         | –                    |
|                      | C51A                | 4G13-1 (1,3)  | –        | Enkel    | –                       | –                | CARB              | F4M21-1<br>F5M21-1 | 4M/T<br>5M/T | –<br>–               |
|                      |                     |               |          |          |                         |                  | ELEC. CARB        | F5M21-1            | 5M/T         | –                    |
|                      | C52A                | 4G15-1 (1,5)  | –        | Enkel    | –                       | –                | CARB              | F5M21-1<br>F3A21-2 | 5M/T<br>3A/T | –<br>–               |
|                      |                     |               |          |          |                         |                  | MPI               | F5M21-1<br>F4A21-2 | 5M/T<br>4A/T | –<br>–               |
|                      | C53A                | 4G61-0 (1,6)  | –        | Dubbel   | X                       | –                | MPI               | F5M22-2            | 5M/T         | –                    |
|                      | C54A                | 4D65-1 (1,8)  | X        | Enkel    | –                       | –                | Diesel S-QGS      | F5M22-1            | 5M/T         | –                    |
| C58A                 | 4G67-0 (1,8)        | X             | Dubbel   | X        | –                       | MPI              | F5M22-2           | 5M/T               | –            |                      |
| Lancer               | C61A                | 4G13-1 (1,3)  | –        | Enkel    | –                       | –                | CARB              | F4M21-1<br>F5M21-1 | 4M/T<br>5M/T | –<br>–               |
|                      |                     |               |          |          |                         |                  | ELEC. CARB        | F5M21-1            | 5M/T         | –                    |
|                      | C62A                | 4G15-1 (1,5)  | –        | Enkel    | –                       | –                | CARB              | F5M21-1<br>F3A21-2 | 5M/T<br>3A/T | –<br>–               |
|                      |                     |               |          |          |                         |                  | MPI               | F5M21-1<br>F4A21-2 | 5M/T<br>4A/T | –                    |
|                      | C63A                | 4G61-0 (1,6)  | –        | Dubbel   | X                       | –                | MPI               | F5M22-2            | 5M/T         | –                    |
| C64A                 | 4D65-1 (1,8)        | X             | Enkel    | –        | –                       | Diesel S-QGS     | F5M22-1           | 5M/T               | –            |                      |

## 1990 modellen voor Europa

| Voertuig-<br>model      | Voertuig<br>model-<br>code | Motor            |          |          |                                 |                           | Brand-<br>stof-<br>systeem | Versnellingsbak    |              |                               |
|-------------------------|----------------------------|------------------|----------|----------|---------------------------------|---------------------------|----------------------------|--------------------|--------------|-------------------------------|
|                         |                            | Model<br>(liter) | Balansas | Nokkenas | Hydrau-<br>lische<br>klepstoter | Turbo-<br>compres-<br>sor |                            | Model              | Type         | Vierwiel-<br>aandrij-<br>ving |
| Lancer                  | C65A                       | 4G16-1<br>(1,2)  | –        | Enkel    | –                               | –                         | CARB                       | F5M21-1            | 5M/T         | –                             |
|                         | C68A                       | 4G67-0<br>(1,8)  | X        | Dubbel   | X                               | –                         | MPI                        | F5M22-2            | 5M/T         | –                             |
|                         | C77A                       | 4G37-8<br>(1,8)  | –        | Enkel    | –                               | –                         | MPI                        | W5M31-2            | 5M/T         | X                             |
| Galant                  | E32A                       | 4G37-7<br>(1,8)  | X        | Enkel    | –                               | –                         | MPI                        | F5M22-1<br>F4A22-2 | 5M/T<br>4A/T | –<br>–                        |
|                         | E39A                       | 4G63-5<br>(2,0)  | X        | Dubbel   | X                               | –                         | MPI                        | W5M31-2            | 5M/T         | X                             |
| Galant<br>Hatch<br>Back | E32A                       | 4G37-7<br>(1,8)  | X        | Enkel    | –                               | –                         | MPI                        | F5M22-1<br>F4A22-2 | 5M/T<br>4A/T | –<br>–                        |
|                         | E39A                       | 4G63-5<br>(2,0)  | X        | Dubbel   | X                               | –                         | MPI                        | W5M31-2            | 5M/T         | X                             |
| Sapporo                 | E16AT                      | 4G64-1<br>(2,4)  | X        | Enkel    | X                               | –                         | MPI                        | F5M31-2<br>F4A22-1 | 5M/T<br>4A/T | –<br>–                        |
| Space<br>Wagon<br>Van   | D05V                       | 4G37-7<br>(1,8)  | X        | Enkel    | –                               | –                         | CARB                       | F5M21-1            | 5M/T         | –                             |
|                         | D09V                       | 4D65-1<br>(1,8)  | X        | Enkel    | –                               | X                         | Diesel<br>S-QGS            | F5M22-1            | 5M/T         | –                             |
|                         | D04W                       | 4G63-3<br>(2,0)  | X        | Enkel    | X                               | –                         | MPI                        | F5M22-1<br>F3A22-2 | 5M/T<br>3A/T | –<br>–                        |
|                         | D05W                       | 4G37-7<br>(1,8)  | X        | Enkel    | –                               | –                         | CARB                       | F5M21-1<br>F3A21-2 | 5M/T<br>3A/T | –<br>–                        |
|                         | D09W                       | 4D65-1<br>(1,8)  | X        | Enkel    | –                               | X                         | Diesel<br>S-QGS            | F5M22-1            | 5M/T         | –                             |
| Space<br>Wagon<br>4WD   | D08W                       | 4G63-3<br>(2,0)  | X        | Enkel    | X                               | –                         | MPI                        | KM182-2            | 5M/T         | X                             |
|                         |                            |                  |          |          |                                 |                           | CARB                       | KM182-2            | 5M/T         | X                             |
| Pajero                  | L042G                      | 4G54-1<br>(2,6)  | X        | Enkel    | X                               | –                         | CARB                       | V5M21-4            | 5M/T         | X                             |
|                         |                            | G54B-1<br>(2,6)  | X        | Enkel    | X                               | –                         | ELEC.<br>CARB              | V5M21-4            | 5M/T         | X                             |
|                         | L047G                      | 4G54-1<br>(2,6)  | X        | Enkel    | X                               | –                         | CARB                       | V5M21-4            | 5M/T         | X                             |
|                         | L049G                      | 4D56-1<br>(2,5)  | X        | Enkel    | –                               | X                         | Diesel                     | V5M21-4            | 5M/T         | X                             |
|                         | L141G                      | 6G72-1<br>(3,0)  | –        | Dubbel   | X                               | –                         | MPI                        | V5MT1-1            | 5M/T         | X                             |

1990 modellen voor Europa

| Voertuig-model | Voertuig-model-code  | Motor         |          |          |                         |                  | Brandstof-systeem | Versnellingsbak    |              |                      |
|----------------|----------------------|---------------|----------|----------|-------------------------|------------------|-------------------|--------------------|--------------|----------------------|
|                |                      | Model (liter) | Balansas | Nokkenas | Hydraulische klepstoter | Turbo-compressor |                   | Model              | Type         | Vierwiel-aandrijving |
| Pajero         | L144G                | 4D56-1 (2,5)  | X        | Enkel    | –                       | X                | Diesel            | V5MT1-1<br>V4AW2-1 | 5M/T<br>4A/T | X<br>X               |
|                | L146G                | 6G72-1 (3,0)  | –        | Dubbel   | X                       | –                | MPI               | V5MT1-1<br>V4AW2-1 | 5M/T<br>4A/T | X<br>X               |
|                | L149G                | 4D56-1 (2,5)  | X        | Enkel    | –                       | X                | Diesel            | V5MT1-1<br>V4AW2-1 | 5M/T<br>4M/T | X<br>X               |
| Starion        | A187A                | G54B-1 (2,6)  | X        | Enkel    | X                       | X                | SPI               | R5M21-4            | 5M/T         | –                    |
| L200           | K11T                 | 4G32-8 (1,6)  | –        | Enkel    | –                       | –                | CARB              | R5M21-1            | 5M/T         | –                    |
|                | K12T                 | 4G63-3 (2,0)  | X        | Enkel    | X                       | –                | CARB              | R5M21-1<br>KM132-H | 5M/T<br>5M/T | –<br>–               |
|                | K14T                 | 4D56-1 (2,5)  | X        | Enkel    | –                       | –                | Diesel            | R5M21-1            | 5M/T         | –                    |
| L200 4WD       | K22T<br>K32T         | 4G63-3 (2,0)  | X        | Enkel    | X                       | –                | CARB              | V5M21-1            | 5M/T         | X                    |
|                | K24T<br>K34T         | 4D56-1 (2,5)  | X        | Enkel    | –                       | –                | Diesel            | V5M21-1            | 5M/T         | X                    |
|                | K33T                 | G54B-1 (2,6)  | X        | Enkel    | X                       | –                | ELEC.<br>CARB     | V5M21-1            | 5M/T         | X                    |
| L300           | P02V<br>P12V         | 4G32-8 (1,6)  | –        | Enkel    | –                       | –                | CARB              | R5M21-2            | 5M/T         | –                    |
|                | L032P                | 4G32-8 (1,6)  | –        | Enkel    | –                       | –                | CARB              | R5M21-3            | 5M/T         | –                    |
|                | P03V<br>P03W         | 4G63-3 (2,0)  | X        | Enkel    | X                       | –                | CARB              | R5M21-2            | 5M/T         | –                    |
|                | P13V                 |               |          |          |                         |                  | ELEC.<br>CARB     | R5M21-2            | 5M/T         | –                    |
|                | P05V<br>P05W<br>P15V | 4D56-1 (2,5)  | X        | Enkel    | –                       | –                | Diesel            | R5M21-2            | 5M/T         | –                    |
|                | L039P                | 4D56-1 (2,5)  | X        | Enkel    | –                       | –                | Diesel<br>S-QGS   | R5M21-3            | 5M/T         | –                    |

## 1990 modellen voor Europa

| Voertuig-<br>model | Voertuig<br>model-<br>code | Motor            |          |          |                                 |                           | Brand-<br>stof-<br>systeem | Versnellingsbak |      |                               |
|--------------------|----------------------------|------------------|----------|----------|---------------------------------|---------------------------|----------------------------|-----------------|------|-------------------------------|
|                    |                            | Model<br>(liter) | Balansas | Nokkenas | Hydrau-<br>lische<br>klepstoter | Turbo-<br>compres-<br>sor |                            | Model           | Type | Vierwiel-<br>aandrij-<br>ving |
| L300<br>4WD        | P23V<br>P23W               | 4G63-3<br>(2,0)  | X        | Enkel    | X                               | –                         | CARB                       | V5M21-2         | 5M/T | X                             |
|                    | P24V<br>P24W               | 4G64-1<br>(2,4)  | X        | Enkel    | X                               | –                         | MPI                        | V5M21-2         | 5M/T | X                             |
|                    | P25V<br>P25W               | 4D56-1<br>(2,5)  | X        | Enkel    | –                               | X                         | Diesel<br>S-QGS            | V5M21-2         | 5M/T | X                             |

## 1990 modellen voor algemene export

| Voertuig-<br>model          | Voertuig<br>model-<br>code | Motor            |          |          |                                 |                           | Brand-<br>stof-<br>systeem | Versnellingsbak               |                      |                               |
|-----------------------------|----------------------------|------------------|----------|----------|---------------------------------|---------------------------|----------------------------|-------------------------------|----------------------|-------------------------------|
|                             |                            | Model<br>(liter) | Balansas | Nokkenas | Hydrau-<br>lische<br>klepstoter | Turbo-<br>compres-<br>sor |                            | Model                         | Type                 | Vierwiel-<br>aandrij-<br>ving |
| Lancer<br>Station-<br>Wagon | C11V                       | 4G13-1<br>(1,3)  | -        | Enkel    | -                               | -                         | CARB                       | F4M21-1<br>F5M21-1            | 4M/T<br>5M/T         | -                             |
|                             | C12V                       | 4G15-1<br>(1,5)  | -        | Enkel    | -                               | -                         | CARB                       | F5M21-1<br>F3A21-2            | 5M/T<br>3A/T         | -                             |
|                             | C37V                       | 4G37-8<br>(1,8)  | -        | Enkel    | -                               | -                         | CARB                       | W5M31-1                       | 5M/T                 | X                             |
| Colt                        | C51A                       | 4G13-1<br>(1,3)  | -        | Enkel    | -                               | -                         | CARB                       | F5M21-1                       | 5M/T                 | -                             |
|                             | C52A                       | 4G15-1<br>(1,5)  | -        | Enkel    | -                               | -                         | CARB                       | F5M21-1<br>F3A21-2            | 5M/T<br>3A/T         | -                             |
|                             | C53A                       | 4G61-0<br>(1,6)  | -        | Dubbel   | X                               | -                         | MPI                        | F5M22-2                       | 5M/T                 | -                             |
|                             | C54A                       | 4D65-1<br>(1,8)  | X        | Enkel    | -                               | -                         | Diesel<br>S-QGS            | F5M21-1                       | 5M/T                 | -                             |
| Lancer                      | C61A                       | 4G13-1<br>(1,3)  | -        | Enkel    | -                               | -                         | CARB                       | F4M21-1<br>F5M21-1<br>F3A21-2 | 4M/T<br>5M/T<br>3A/T | -<br>-<br>-                   |
|                             | C62A                       | 4G15-1<br>(1,5)  | -        | Enkel    | -                               | -                         | CARB                       | F5M21-1<br>F3A21-2            | 5M/T<br>3A/T         | -<br>-                        |
|                             |                            |                  |          |          |                                 |                           | MPI                        | F5M21-1<br>F4A21-2            | 5M/T<br>4A/T         | -<br>-                        |
|                             | C63A                       | 4G61-0<br>(1,6)  | -        | Dubbel   | X                               | -                         | MPI                        | F5M22-2                       | 5M/T                 | -                             |
|                             | C64A                       | 4D65-1<br>(1,8)  | X        | Enkel    | -                               | -                         | Diesel<br>S-QGS            | F5M21-1<br>F5M22-1            | 5M/T<br>5M/T         | -<br>-                        |
| Space<br>Wagon              | D05W                       | 4G37-7<br>(1,8)  | X        | Enkel    | -                               | -                         | CARB                       | F5M21-1<br>F3A21-2            | 5M/T<br>3A/T         | -<br>-                        |
|                             | D04W                       | 4G63-3<br>(2,0)  | X        | Enkel    | -                               | -                         | CARB                       | F5M22-1                       | 5M/T                 | -                             |
| Galant                      | E15A                       | 4G63-3<br>(2,0)  | X        | Enkel    | -                               | -                         | CARB                       | F5M22-1                       | 5M/T                 | -                             |
|                             | E16A                       | 4G64-1<br>(2,4)  | X        | Enkel    | -                               | -                         | MPI                        | F5M31-2<br>F4A22-1            | 5M/T<br>4A/T         | -<br>-                        |
| Galant                      | E32A                       | 4G37-7<br>(1,8)  | X        | Enkel    | -                               | -                         | CARB                       | F5M22-1<br>F4A21-2            | 5M/T<br>4A/T         | -<br>-                        |
|                             | E33A                       | 4G63-3<br>(2,0)  | X        | Enkel    | -                               | -                         | CARB                       | F5M22-1<br>F4A22-2            | 5M/T<br>4A/T         | -<br>-                        |
|                             |                            |                  |          |          |                                 |                           | MPI                        | F5M22-2                       | 5M/T                 | -                             |
|                             |                            | 4G63-5<br>(2,0)  | X        | Dubbel   | X                               | -                         | MPI                        | F5M22-2                       | 5M/T                 | -                             |

## 1990 modellen voor algemene export

| Voertuig-<br>model | Voertuig<br>model-<br>code   | Motor            |          |          |                                 |                           | Brand-<br>stof-<br>systeem | Versnellingsbak    |              |                               |
|--------------------|------------------------------|------------------|----------|----------|---------------------------------|---------------------------|----------------------------|--------------------|--------------|-------------------------------|
|                    |                              | Model<br>(liter) | Balansas | Nokkenas | Hydrau-<br>lische<br>klepstoter | Turbo-<br>compres-<br>sor |                            | Model              | Type         | Vierwiel-<br>aandrij-<br>ving |
| Pajero             | L042G<br>L047G               | 4G54-1<br>(2,6)  | –        | Enkel    | –                               | –                         | CARB                       | V5M21-4<br>V4AW2-1 | 5M/T<br>4A/T | X<br>X                        |
|                    | L044G                        | 4D56-1<br>(2,5)  | X        | Enkel    | –                               | –                         | Diesel                     | V5M21-4            | 5M/T         | X                             |
|                    | L049G                        | 4D56-1<br>(2,5)  | X        | Enkel    | –                               | –                         | Diesel<br>Diesel           | V5M21-4<br>V5M21-4 | 5M/T<br>5M/T | X<br>X                        |
|                    | L146G                        | 6G72-1<br>(3,0)  | –        | Dubbel   | X                               | –                         | MPI                        | V5MT1-1<br>V4AW2-1 | 5M/T<br>4A/T | X<br>X                        |
| Starion            | A183A                        | 4G63-0<br>(2,0)  | X        | Enkel    | –                               | X                         | SPI                        | R5M21-4            | 5M/T         | –                             |
| L200               | K01T<br>K11T                 | 4G32-8<br>(1,6)  | –        | Enkel    | –                               | –                         | CARB                       | R4M21-1            | 4M/T         | –                             |
|                    | K02T<br>K12T                 | 4G63-4<br>(2,0)  | –        | Enkel    | –                               | –                         | CARB                       | R5M21-1            | 5M/T         | –                             |
|                    | K14T                         | 4D56-1<br>(2,5)  | X        | Enkel    | –                               | –                         | Diesel                     | R5M21-1            | 5M/T         | –                             |
| L200<br>4WD        | K22T<br>K32T                 | 4G63-4<br>(2,0)  | –        | Enkel    | –                               | –                         | CARB                       | V5M21-1            | 5M/T         | X                             |
|                    | K24T<br>K34T                 | 4D56-1<br>(2,5)  | X        | Enkel    | –                               | –                         | Diesel                     | V5M21-1            | 5M/T         | X                             |
| L300               | P01V<br>P01W                 | 4G33-8<br>(1,4)  | –        | Enkel    | –                               | –                         | CARB                       | R4M21-2            | 4M/T         | –                             |
|                    | P02V<br>P12V<br>P12W         | 4G32-8<br>(1,6)  | –        | Enkel    | –                               | –                         | CARB                       | R4M21-2            | 4M/T         | –                             |
|                    | P02W                         | 4G32-8<br>(1,6)  | –        | Enkel    | –                               | –                         | CARB                       | R5M21-2            | 5M/T         | –                             |
|                    | P03W<br>P13W                 | 4G63-4<br>(2,0)  | –        | Enkel    | –                               | –                         | CARB                       | R5M21-2<br>R4AW2-2 | 5M/T<br>4A/T | –<br>–                        |
|                    | P05V<br>P05W<br>P15V<br>P15W | 4D56-1<br>(2,5)  | –        | Enkel    | –                               | –                         | Diesel                     | R5M21-2            | 5M/T         | –                             |
| L300<br>4WD        | P23W                         | 4G63-4<br>(2,0)  | –        | Enkel    | –                               | –                         | CARB                       | V5M21-2            | 5M/T         | X                             |

1990 modellen voor Australië

| Voertuig-model | Voertuig-model-code  | Motor         |          |          |                         |                  | Brandstof-systeem | Versnellingsbak    |              |                      |
|----------------|----------------------|---------------|----------|----------|-------------------------|------------------|-------------------|--------------------|--------------|----------------------|
|                |                      | Model (liter) | Balansas | Nokkenas | Hydraulische klepstoter | Turbo-compressor |                   | Model              | Type         | Vierwiel-aandrijving |
| Lancer         | C52A                 | 4G15-1 (1,5)  | –        | Enkel    | –                       | –                | MPI               | F5M21-1<br>F4A21-2 | 5M/T<br>4A/T | –<br>–               |
|                | C62A                 | 4G15-1 (1,5)  | –        | Enkel    | –                       | –                | CARB              | F5M21-1<br>F3A21-2 | 5M/T<br>3A/T | –<br>–               |
|                |                      |               |          |          |                         |                  | MPI               | F5M21-1<br>F4A21-2 | 5M/T<br>4A/T | –<br>–               |
| Space Wagon    | D04W                 | 4G63-3 (2,0)  | X        | Enkel    | X                       | –                | CARB              | F5M22-1<br>F3A22-2 | 5M/T<br>3A/T | –<br>–               |
| Pajero         | L042G<br>L047G       | 4G54-1 (2,6)  | X        | Enkel    | X                       | –                | CARB              | V5M21-4            | 5M/T         | X                    |
|                | L049G                | 4D56-1 (2,5)  | X        | Enkel    | –                       | X                | Diesel            | V5M21-4            | 5M/T         | X                    |
|                | L149G                | 4D56-1 (2,5)  | X        | Enkel    | –                       | X                | Diesel            | V5MT1-1            | 5M/T         | X                    |
|                | L146G                | 6G72-1 (3,0)  | –        | Dubbel   | X                       | –                | MPI               | V5MT1-1<br>V4AW2-1 | 5M/T<br>4A/T | X<br>X               |
| L200           | K13T                 | 4G54-1 (2,6)  | X        | Enkel    | X                       | –                | CARB              | R5M21-1            | 5M/T         | –                    |
|                | K14T                 | 4D56-1 (2,5)  | X        | Enkel    | –                       | –                | Diesel            | R5M21-1            | 5M/T         | –                    |
| L200 4WD       | K33T                 | 4G54-1 (2,6)  | X        | Enkel    | X                       | –                | CARB              | V5M21-1            | 5M/T         | X                    |
|                | K34T                 | 4D56-1 (2,6)  | X        | Enkel    | –                       | –                | Diesel            | V5M21-1            | 5M/T         | X                    |
| L300           | P03V<br>P03W<br>P13V | 4G63-3 (2,0)  | X        | Enkel    | X                       | –                | CARB              | R5M21-2<br>R4AW2-2 | 5M/T<br>4A/T | –<br>–               |
|                | P04W                 | 4G64-1 (2,4)  | X        | Enkel    | X                       | –                | MPI               | R5M21-2<br>R4AW2-2 | 5M/T<br>4A/T | –<br>–               |
|                | P05V<br>P15V         | 4D56-1 (2,5)  | X        | Enkel    | –                       | –                | Diesel            | R5M21-2            | 5M/T         | –                    |
| L300 4WD       | P24V<br>P24W         | 4G64-1 (2,4)  | X        | Enkel    | X                       | –                | MPI               | V5M21-2            | 5M/T         | X                    |



## 1991 modellen voor Europa

| Voertuig-<br>model          | Voertuig<br>model-<br>code | Motor            |          |          |                                 |                           | Brand-<br>stof-<br>systeem | Vernellingsbak |         |                               |
|-----------------------------|----------------------------|------------------|----------|----------|---------------------------------|---------------------------|----------------------------|----------------|---------|-------------------------------|
|                             |                            | Model<br>(liter) | Balansas | Nokkenas | Hydrau-<br>lische<br>klepstoter | Turbo-<br>compres-<br>sor |                            | Model          | Type    | Vierwiel-<br>aandrij-<br>ving |
| Lancer<br>Station-<br>Wagon | C12V                       | 4G15-2<br>(1,5)  | -        | Enkel    | -                               | -                         | CARB                       | F5M21-1        | 5M/T    | -                             |
|                             |                            |                  |          |          |                                 |                           |                            | F3A21-2        | 3A/T    | -                             |
|                             | MPI                        | F5M21-1          | 5M/T     | -        |                                 |                           |                            |                |         |                               |
|                             | C14V                       | 4D65-1<br>(1,8)  | X        | Enkel    | -                               | -                         | Diesel<br>S-QGS            | F5M22-1        | 5M/T    | -                             |
| C37V                        | 4G37-8<br>(1,8)            | -                | Enkel    | -        | -                               | CARB                      | W5M31-1                    | 5M/T           | X       |                               |
|                             |                            |                  |          |          |                                 |                           | MPI                        | W5M31-1        | 5M/T    | X                             |
| Colt                        | C51V                       | 4G13-2<br>(1,3)  | -        | Enkel    | -                               | -                         | CARB                       | F5M21-1        | 5M/T    | -                             |
|                             | C51A                       | 4G13-2<br>(1,3)  | -        | Enkel    | -                               | -                         | CARB                       | F5M21-1        | 5M/T    | -                             |
|                             |                            |                  |          |          |                                 |                           |                            | ELEC.<br>CARB  | F5M21-1 | 5M/T                          |
|                             | C52A                       | 4G15-2<br>(1,5)  | -        | Enkel    | -                               | -                         | CARB                       | F5M21-1        | 5M/T    | -                             |
|                             |                            |                  |          |          |                                 |                           |                            | F3A21-2        | 3A/T    | -                             |
|                             | MPI                        | F5M21-1          | 5M/T     | -        |                                 |                           |                            |                |         |                               |
|                             | F4A21-2                    | 4A/T             | -        |          |                                 |                           |                            |                |         |                               |
| C54A                        | 4D65-1<br>(1,8)            | X                | Enkel    | -        | -                               | Diesel<br>S-QGS           | F5M22-1                    | 5M/T           | -       |                               |
| C58A                        | 4G67-0<br>(1,8)            | X                | Dubbel   | X        | -                               | MPI                       | F5M22-2                    | 5M/T           | -       |                               |
| C87A                        | 4G37-8<br>(1,8)            | -                | Enkel    | -        | -                               | MPI                       | W5M31-2                    | 5M/T           | X       |                               |
| Lancer                      | C61A                       | 4G13-2<br>(1,3)  | -        | Enkel    | -                               | -                         | CARB                       | F5M21-1        | 5M/T    | -                             |
|                             |                            |                  |          |          |                                 |                           |                            | ELEC.<br>CARB  | F5M21-1 | 5M/T                          |
|                             | C62A                       | 4G15-2<br>(1,5)  | -        | Enkel    | -                               | -                         | CARB                       | F5M21-1        | 5M/T    | -                             |
|                             |                            |                  |          |          |                                 |                           |                            | F3A21-2        | 3A/T    | -                             |
|                             | MPI                        | F5M21-1          | 5M/T     | -        |                                 |                           |                            |                |         |                               |
|                             | F4A21-2                    | 4A/T             | -        |          |                                 |                           |                            |                |         |                               |
| C64A                        | 4D65-1<br>(1,8)            | X                | Enkel    | -        | -                               | Diesel<br>S-QGS           | F5M22-1                    | 5M/T           | -       |                               |
| C65A                        | 4G16-1<br>(1,2)            | -                | Enkel    | -        | -                               | CARB                      | F5M21-1                    | 5M/T           | -       |                               |
| C68A                        | 4G67-0<br>(1,8)            | X                | Dubbel   | X        | -                               | CARB                      | F5M22-2                    | 5M/T           | -       |                               |

## 1991 modellen voor Europa

| Voertuig-model  | Voertuig-model-code | Motor         |          |          |                         |                  | Brandstof-systeem | Versnellingsbak    |              |                      |
|-----------------|---------------------|---------------|----------|----------|-------------------------|------------------|-------------------|--------------------|--------------|----------------------|
|                 |                     | Model (liter) | Balansas | Nokkenas | Hydraulische klepstoter | Turbo-compressor |                   | Model              | Type         | Vierwiel-aandrijving |
| Lancer          | C77A                | 4G37-8 (1,8)  | -        | Enkel    | -                       | -                | MPI               | W5M31-2            | 5M/T         | X                    |
| Galant          | E31A                | 4G32-8 (1,6)  | -        | Enkel    | -                       | -                | CARB              | F5M21-1            | 5M/T         | -                    |
|                 | E32A                | 4G37-7 (1,8)  | X        | Enkel    | -                       | -                | CARB              | F5M22-1<br>F4A21-2 | 5M/T<br>4A/T | -<br>-               |
|                 |                     |               |          |          |                         |                  | MPI               | F5M22-1<br>F4A22-2 | 5M/T<br>4A/T | -<br>-               |
|                 | E33A                | 4G63-3 (2,0)  | X        | Enkel    | X                       | -                | MPI               | F5M22-1<br>F4A22-2 | 5M/T<br>4A/T | -<br>-               |
|                 |                     | 4G63-5 (2,0)  | X        | Dubbel   | X                       | -                | MPI               | F5M22-2            | 5M/T         | -                    |
|                 | E34A                | 4D65-1 (1,8)  | X        | Enkel    | -                       | X                | Diesel S-QGS      | F5M31-1<br>F4A21-2 | 5M/T<br>4A/T | -<br>-               |
|                 | E38A                | 4G63-3 (2,0)  | X        | Enkel    | X                       | -                | MPI               | W5M31-2            | 5M/T         | X                    |
|                 | E39A                | 4G63-3 (2,0)  | X        | Enkel    | X                       | -                | MPI               | W5M31-2            | 5M/T         | X                    |
| 4G63-5 (2,0)    |                     | X             | Dubbel   | X        | -                       | MPI              | W5M31-2           | 5M/T               | X            |                      |
| Space Wagon Van | D05V                | 4G37-7 (1,8)  | X        | Enkel    | -                       | -                | CARB              | F5M21-1            | 5M/T         | -                    |
|                 | D09V                | 4D65-1 (1,8)  | X        | Enkel    | -                       | X                | Diesel S-QGS      | F5M22-1            | 5M/T         | -                    |
|                 | D04W                | 4G63-3 (2,0)  | X        | Enkel    | X                       | -                | MPI               | F5M22-1<br>F3A22-2 | 5M/T<br>3A/T | -<br>-               |
|                 | D05W                | 4G37-7 (1,8)  | X        | Enkel    | -                       | -                | CARB              | F5M21-1<br>F3A21-2 | 5M/T<br>3A/T | -<br>-               |
|                 | D09W                | 4D65-1 (1,8)  | X        | Enkel    | -                       | X                | Diesel S-QGS      | F5M22-1            | 5M/T         | -                    |
| Space Wagon 4WD | D08W                | 4G63-3 (2,0)  | X        | Enkel    | X                       | -                | CARB              | KM182-2            | 5M/T         | X                    |
|                 |                     |               |          |          |                         |                  | MPI               | KM182-2            | 5M/T         | X                    |
| Pajero          | V21C                | 4G64-1 (2,4)  | X        | Enkel    | X                       | -                | MPI               | V5M21-5            | 5M/T         | X                    |
|                 | V23C                | 6G72-1 (3,0)  | -        | Dubbel   | X                       | -                | MPI               | V4AW2-3            | 4A/T         | X                    |
|                 | V24C                | 4D56-1 (2,5)  | X        | Enkel    | -                       | X                | Diesel            | V5MT1-3            | 5M/T         | X                    |

## 1991 modellen voor Europa

| Voertuig-model | Voertuig-model-code | Motor           |          |          |                         |                  | Brandstofsysteem | Vernellingsbak     |              |                      |
|----------------|---------------------|-----------------|----------|----------|-------------------------|------------------|------------------|--------------------|--------------|----------------------|
|                |                     | Model (liter)   | Balansas | Nokkenas | Hydraulische klepstoter | Turbo-compressor |                  | Model              | Type         | Vierwiel-aandrijving |
| Pajero         | V24V<br>V44V        | 4D56-1<br>(2,5) | X        | Enkel    | –                       | X                | Diesel           | V5MT1-3            | 5M/T         | X                    |
|                | V21W                | 4G64-1<br>(2,4) | X        | Enkel    | X                       | –                | MPI              | V5M21-5            | 5M/T         | X                    |
|                | V23W                | 6G72-1<br>(3,0) | –        | Dubbel   | X                       | –                | MPI              | V4AW2-3            | 4A/T         | X                    |
|                | V24W                | 4D56-1<br>(2,5) | X        | Enkel    | –                       | X                | Diesel           | V5MT1-3            | 5M/T         | X                    |
|                | V41W                | 4G64-1<br>(2,4) | X        | Enkel    | X                       | –                | MPI              | V5M21-5            | 5M/T         | X                    |
|                | V43W                | 6G72-1<br>(3,0) | –        | Dubbel   | X                       | –                | MPI              | V5MT1-3<br>V4AW2-3 | 5M/T<br>4A/T | X<br>X               |
|                | V44W                | 4D56-1<br>(2,5) | X        | Enkel    | –                       | X                | Diesel           | V5MT1-3<br>V4AW2-3 | 5M/T<br>4A/T | X<br>X               |
| L200           | K11T                | 4G32-8<br>(1,6) | –        | Enkel    | –                       | –                | CARB             | R5M21-1            | 5M/T         | –                    |
|                | K12T                | 4G63-3<br>(2,0) | X        | Enkel    | X                       | –                | CARB             | R5M21-1            | 5M/T         | –                    |
|                | K14T                | 4D56-1<br>(2,5) | X        | Enkel    | –                       | –                | Diesel           | R5M21-1            | 5M/T         | –                    |
| L200<br>4WD    | K22T<br>K32T        | 4G63-3<br>(2,0) | X        | Enkel    | X                       | –                | CARB             | V5M21-1            | 5M/T         | X                    |
|                | K24T<br>K34T        | 4D56-1<br>(2,5) | X        | Enkel    | –                       | –                | Diesel           | V5M21-1            | 5M/T         | X                    |
|                | K33T                | G54B-1<br>(2,6) | X        | Enkel    | X                       | –                | ELEC.<br>CARB    | V5M21-1            | 5M/T         | X                    |
| L300           | P02V<br>P12V        | 4G32-8<br>(1,6) | –        | Enkel    | –                       | –                | CARB             | R5M21-2            | 5M/T         | –                    |
|                | L032P               | 4G32-8<br>(1,6) | –        | Enkel    | –                       | –                | CARB             | R5M21-3            | 5M/T         | –                    |
|                | P03W                | 4G63-3<br>(2,0) | X        | Enkel    | X                       | –                | CARB             | R5M21-2            | 5M/T         | –                    |
|                |                     |                 |          |          |                         |                  |                  | ELEC.<br>CARB      | R5M21-2      | 5M/T                 |
|                | P03V                | 4G63-3<br>(2,0) | X        | Enkel    | X                       | –                | ELEC.<br>CARB    | R5M21-2            | 5M/T         | –                    |
|                | P13V                | 4G63-3<br>(2,0) | X        | Enkel    | X                       | –                | CARB             | R5M21-2            | 5M/T         | –                    |
|                |                     |                 |          |          |                         |                  |                  | ELEC.<br>CARB      | R5M21-2      | 5M/T                 |
| P04W           | 4G64-1<br>(2,4)     | X               | Enkel    | X        | –                       | MPI              | R5M21-2          | 5M/T               | –            |                      |

## 1991 modellen voor Europa

| Voertuig-<br>model | Voertuig<br>model-<br>code | Motor            |          |          |                                 |                           | Brand-<br>stof-<br>systeem | Versnellingsbak    |              |                               |
|--------------------|----------------------------|------------------|----------|----------|---------------------------------|---------------------------|----------------------------|--------------------|--------------|-------------------------------|
|                    |                            | Model<br>(liter) | Balansas | Nokkenas | Hydrau-<br>lische<br>klepstoter | Turbo-<br>compres-<br>sor |                            | Model              | Type         | Vierwiel-<br>aandrij-<br>ving |
| L300               | P05V<br>P05W<br>P15V       | 4D56-1<br>(2,5)  | X        | Enkel    | –                               | –                         | Diesel                     | R5M21-2            | 5M/T         | –                             |
|                    | L039P                      | 4D56-1<br>(2,5)  | –        | Enkel    | –                               | –                         | Diesel                     | R5M21-3            | 5M/T         | –                             |
|                    |                            |                  |          |          |                                 |                           | Diesel<br>S-QGS            | R5M21-3            | 5M/T         | –                             |
| L300<br>4WD        | P23V<br>P23W               | 4G63-3<br>(2,0)  | X        | Enkel    | X                               | –                         | CARB                       | V5M21-2            | 5M/T         | X                             |
|                    | P24V<br>P24W               | 4G64-1<br>(2,4)  | X        | Enkel    | X                               | –                         | ELEC.<br>CARB              | V5M21-2            | 5M/T         | X                             |
|                    | P25V<br>P25W               | 4D56-1<br>(2,5)  | X        | Enkel    | –                               | X                         | Diesel<br>S-QGS            | V5M21-2            | 5M/T         | X                             |
| Sigma              | F16A                       | 6G72-1<br>(3,0)  | –        | Dubbel   | X                               | –                         | MPI                        | F5M33-2<br>F4A33-1 | 5M/T<br>4A/T | –<br>–                        |
|                    |                            | 6G72-4<br>(3,0)  | –        | Vier     | X                               | –                         | MPI                        | F5M33-2<br>F4A33-1 | 5M/T<br>4A/T | –<br>–                        |
| Eclipse            | D22A                       | 4G63-5<br>(2,0)  | X        | Dubbel   | X                               | –                         | MPI                        | F5M31-2            | 5M/T         | –                             |
|                    | D27A                       | 4G63-5<br>(2,0)  | X        | Dubbel   | X                               | –                         | MPI                        | W5M31-2            | 5M/T         | X                             |

## 1991 modellen voor algemene export

| Voertuig-model              | Voertuig model-code | Motor<br>Model<br>(liter) | Motor    |          |                                 |                           | Brand-<br>stof-<br>systeem | Versnellingsbak               |                      |                               |
|-----------------------------|---------------------|---------------------------|----------|----------|---------------------------------|---------------------------|----------------------------|-------------------------------|----------------------|-------------------------------|
|                             |                     |                           | Balansas | Nokkenas | Hydrau-<br>lische<br>klepstoter | Turbo-<br>compres-<br>sor |                            | Model                         | Type                 | Vierwiel-<br>aandrij-<br>ving |
| Lancer<br>Station-<br>Wagon | C11V                | 4G13-2<br>(1,3)           | –        | Enkel    | –                               | –                         | CARB                       | F4M21-1<br>F5M21-1            | 4M/T<br>5M/T         | –<br>–                        |
|                             | C12V                | 4G15-2<br>(1,5)           | –        | Enkel    | –                               | –                         | CARB                       | F5M21-1<br>F3A21-2            | 5M/T<br>3A/T         | –<br>–                        |
|                             | C37V                | 4G37-8<br>(1,8)           | –        | Enkel    | –                               | –                         | CARB                       | W5M31-1                       | 5M/T                 | X                             |
| Colt                        | C51A                | 4G13-2<br>(1,3)           | –        | Enkel    | –                               | –                         | CARB                       | F5M21-1                       | 5M/T                 | –                             |
|                             | C52A                | 4G15-2<br>(1,5)           | –        | Enkel    | –                               | –                         | CARB                       | F5M21-1<br>F3A21-2            | 5M/T<br>3A/T         | –<br>–                        |
|                             | C54A                | 4D65-1<br>(1,8)           | X        | Enkel    | –                               | –                         | Diesel<br>S-QGS            | F5M21-1                       | 5M/T                 | –                             |
|                             | C58A                | 4G67-0<br>(1,8)           | X        | Dubbel   | X                               | –                         | MPI                        | F5M22-2                       | 5M/T                 | –                             |
| Lancer                      | C61A                | 4G13-2<br>(1,3)           | –        | Enkel    | –                               | –                         | CARB                       | F4M21-1<br>F5M21-1<br>F3A21-2 | 4M/T<br>5M/T<br>3A/T | –<br>–<br>–                   |
|                             | C62A                | 4G15-2<br>(1,5)           | –        | Enkel    | –                               | –                         | CARB                       | F5M21-1<br>F3A21-2            | 5M/T<br>3A/T         | –<br>–                        |
|                             |                     |                           |          |          |                                 |                           | MPI                        | F5M21-1<br>F4A21-2            | 5M/T<br>4A/T         | –<br>–                        |
|                             | C64A                | 4D65-1<br>(1,8)           | X        | Enkel    | –                               | –                         | Diesel<br>S-QGS            | F5M21-1<br>F5M22-1            | 5M/T<br>5M/T         | –<br>–                        |
|                             | C68A                | 4G67-0<br>(1,8)           | X        | Dubbel   | X                               | –                         | MPI                        | F5M22-2                       | 5M/T                 | –                             |
| Space<br>Wagon              | D05W                | 4G37-7<br>(1,8)           | X        | Enkel    | –                               | –                         | CARB                       | F5M21-1<br>F3A21-2            | 5M/T<br>3A/T         | –                             |
|                             | D04W                | 4G63-3<br>(2,0)           | X        | Enkel    | –                               | –                         | CARB                       | F5M22-1                       | 5M/T                 | –                             |
| Galant                      | E15A                | 4G63-3<br>(2,0)           | X        | Enkel    | –                               | –                         | CARB                       | F5M22-1                       | 5M/T                 | –                             |
| Galant                      | E31A                | 4G32-8<br>(1,6)           | –        | Enkel    | –                               | –                         | CARB                       | F5M21-1<br>F4A21-2            | 5M/T<br>4A/T         | –<br>–                        |
|                             | E32A                | 4G37-7<br>(1,8)           | X        | Enkel    | –                               | –                         | CARB                       | F5M22-1<br>F4A21-2            | 5M/T<br>4A/T         | –<br>–                        |
|                             | E33A                | 4G63-3<br>(2,0)           | X        | Enkel    | –                               | –                         | CARB                       | F5M22-1<br>F4A22-2            | 5M/T<br>4A/T         | –<br>–                        |
|                             |                     |                           |          |          |                                 |                           | MPI                        | F5M22-1<br>F4A22-2            | 5M/T<br>4A/T         | –<br>–                        |
|                             |                     | 4G63-5<br>(2,0)           | X        | Dubbel   | X                               | –                         | MPI                        | F5M22-2<br>F4A22-2            | 5M/T<br>4A/T         | –<br>–                        |

## 1991 modellen voor algemene export

| Voertuig-<br>model | Voertuig-<br>model-<br>code  | Motor            |          |          |                                 |                           | Brand-<br>stof-<br>systeem | Versnellingsbak    |              |                               |
|--------------------|------------------------------|------------------|----------|----------|---------------------------------|---------------------------|----------------------------|--------------------|--------------|-------------------------------|
|                    |                              | Model<br>(liter) | Balansas | Nokkenas | Hydrau-<br>lische<br>klepstoter | Turbo-<br>compres-<br>sor |                            | Model              | Type         | Vierwiel-<br>aandrij-<br>ving |
| Galant             | E39A                         | 4G63-5<br>(2,0)  | X        | Dubbel   | X                               | X                         | MPI                        | W5M33-2            | 5M/T         | X                             |
| Pajero             | L042G                        | 4G54-1<br>(2,6)  | –        | Enkel    | –                               | –                         | CARB                       | V5M21-4            | 5M/T         | X                             |
|                    | L044G                        | 4D56-1<br>(2,5)  | X        | Enkel    | –                               | –                         | Diesel                     | V5M21-4            | 5M/T         | X                             |
|                    | L047G                        | 4G54-1<br>(2,6)  | –        | Enkel    | –                               | –                         | CARB                       | V5M21-4<br>V4AW2-1 | 5M/T<br>4A/T | X<br>X                        |
|                    | L049G                        | 4D56-1<br>(2,5)  | X        | Enkel    | –                               | –                         | Diesel<br>Diesel           | V5M21-4<br>V5M21-4 | 5M/T<br>5M/T | X<br>X                        |
|                    | L146G                        | 6G72-1<br>(3,0)  | –        | Dubbel   | X                               | –                         | MPI                        | V5MT1-1<br>V4AW2-1 | 5M/T<br>4A/T | X<br>X                        |
|                    | V12C<br>V12V<br>V12W<br>V32V | 4G54-1<br>(2,6)  | –        | Enkel    | –                               | –                         | CARB                       | V5M21-5            | 5M/T         | X                             |
|                    | V14C<br>V14V<br>V34V         | 4D56-1<br>(2,5)  | X        | Enkel    | –                               | –                         | Diesel                     | V5M21-5            | 5M/T         | X                             |
|                    | V23W<br>V43W                 | 6G72-1<br>(3,0)  | –        | Dubbel   | X                               | –                         | MPI                        | V5MT1-3            | 5M/T         | X                             |
|                    | V24W<br>V44W                 | 4D56-1<br>(2,5)  | X        | Enkel    | –                               | X                         | Diesel                     | V5MT1-3            | 5M/T         | X                             |
|                    | V32W                         | 4G54-1<br>(2,6)  | –        | Enkel    | –                               | –                         | CARB                       | V5M21-3<br>V4AW2-3 | 5M/T<br>4A/T | X<br>X                        |
| L200               | K01T<br>K11T                 | 4G32-8<br>(1,6)  | –        | Enkel    | –                               | –                         | CARB                       | R4M21-1            | 4M/T         | –                             |
|                    | K02T<br>K12T                 | 4G63-4<br>(2,0)  | –        | Enkel    | –                               | –                         | CARB                       | R5M21-1            | 5M/T         | –                             |
|                    | K03T<br>K13T                 | 4G54-1<br>(2,6)  | –        | Enkel    | –                               | –                         | CARB                       | R5M21-1            | 5M/T         | –                             |
|                    | K14T                         | 4D56-1<br>(2,5)  | X        | Enkel    | –                               | –                         | Diesel                     | R5M21-1            | 5M/T         | –                             |
| L200<br>4WD        | K22T<br>K32T                 | 4G63-4<br>(2,0)  | –        | Enkel    | –                               | –                         | CARB                       | V5M21-1            | 5M/T         | X                             |
|                    | K24T<br>K34T                 | 4D56-1<br>(2,5)  | X        | Enkel    | –                               | –                         | Diesel                     | V5M21-1            | 5M/T         | X                             |

## 1991 modellen voor algemene export

| Voertuig-<br>model | Voertuig<br>model-<br>code | Motor            |          |          |                                 |                           | Brand-<br>stof-<br>systeem | Versnellingsbak    |              |                               |
|--------------------|----------------------------|------------------|----------|----------|---------------------------------|---------------------------|----------------------------|--------------------|--------------|-------------------------------|
|                    |                            | Model<br>(liter) | Balansas | Nokkenas | Hydrau-<br>lische<br>klepstoter | Turbo-<br>compres-<br>sor |                            | Model              | Type         | Vierwiel-<br>aandrij-<br>ving |
| L300               | P01V<br>P01W               | 4G33-8<br>(1,4)  | –        | Enkel    | –                               | –                         | CARB                       | R4M21-2            | 4M/T         | –                             |
|                    | P02V<br>P12V<br>P12W       | 4G32-8<br>(1,6)  | –        | Enkel    | –                               | –                         | CARB                       | R4M21-2            | 4M/T         | –                             |
|                    | P03V<br>P13V<br>P13W       | 4G63-4<br>(2,0)  | –        | Enkel    | –                               | –                         | CARB                       | R5M21-2            | 5M/T         | –                             |
|                    | P03W                       | 4G63-4<br>(2,0)  | –        | Enkel    | –                               | –                         | CARB                       | R5M21-2<br>R4AW2-2 | 5M/T<br>4A/T | –                             |
|                    | P05V<br>P15V<br>P15W       | 4D56-1<br>(2,5)  | X        | Enkel    | –                               | –                         | Diesel                     | R5M21-2            | 5M/T         | –                             |
|                    | P05W                       | 4D56-1<br>(2,5)  | X        | Enkel    | –                               | –                         | Diesel                     | R5M21-2<br>R4AW2-2 | 5M/T<br>4A/T | –                             |
| L300<br>4WD        | P23W                       | 4G63-4<br>(2,0)  | –        | Enkel    | –                               | –                         | CARB                       | V5M21-2            | 5M/T         | X                             |

1991 modellen voor Australië

| Voertuig-model | Voertuig-model-code | Motor         |          |          |                         |                  | Brandstof-systeem | Versnellingsbak    |              |                      |
|----------------|---------------------|---------------|----------|----------|-------------------------|------------------|-------------------|--------------------|--------------|----------------------|
|                |                     | Model (liter) | Balansas | Nokkenas | Hydraulische klepstoter | Turbo-compressor |                   | Model              | Type         | Vierwiel-aandrijving |
| Lancer         | C52A                | 4G15-2 (1,5)  | –        | Enkel    | –                       | –                | MPI               | F5M21-1<br>F4A21-2 | 5M/T<br>4A/T | –<br>–               |
|                | C53A<br>C63A        | 4G61-0 (1,6)  | –        | Dubbel   | X                       | –                | MPI               | F5M22-2            | 5M/T         | –                    |
|                | C62A                | 4G15-2 (1,5)  | –        | Enkel    | –                       | –                | CARB              | F5M21-1<br>F3A21-2 | 5M/T<br>3A/T | –<br>–               |
|                |                     |               |          |          |                         |                  | MPI               | F5M21-1<br>F4A21-2 | 5M/T<br>4A/T | –<br>–               |
| Galant         | E33A                | 4G63-3 (2,0)  | X        | Enkel    | X                       | –                | MPI               | F5M22-1<br>F4A22-2 | 5M/T<br>4A/T | –<br>–               |
|                |                     | 4G63-5 (2,0)  | X        | Dubbel   | X                       | –                | MPI               | F5M22-2<br>F4A22-2 | 5M/T<br>4A/T | –<br>–               |
|                | E39A                | 4G63-5 (2,0)  | X        | Dubbel   | X                       | X                | MPI               | W5M33-2            | 5M/T         | X                    |
| Space Wagon    | D04W                | 4G63-3 (2,0)  | X        | Enkel    | X                       | –                | CARB              | F5M22-1<br>F3A22-2 | 5M/T<br>3A/T | –<br>–               |
| Pajero         | V12W<br>V32W        | 4G54-1 (2,6)  | X        | Enkel    | X                       | –                | CARB              | V5M21-5            | 5M/T         | X                    |
|                | V23W                | 6G72-1 (3,0)  | –        | Dubbel   | X                       | –                | MPI               | V5MT1-3            | 5M/T         | X                    |
|                | V43W                | 6G72-1 (3,0)  | –        | Dubbel   | X                       | –                | MPI               | V5MT1-3<br>V4AW2-3 | 5M/T<br>4A/T | X<br>X               |
|                | V44W                | 4D56-1 (2,5)  | X        | Enkel    | –                       | X                | Diesel            | V5MT1-3            | 5M/T         | X                    |
| L200           | K13T                | 4G54-1 (2,6)  | X        | Enkel    | X                       | –                | CARB              | R5M21-1            | 5M/T         | –                    |
|                | K14T                | 4D56-1 (2,5)  | X        | Enkel    | –                       | –                | Diesel            | R5M21-1            | 5M/T         | –                    |
| L200 4WD       | K33T                | 4G54-1 (2,6)  | X        | Enkel    | X                       | –                | CARB              | V5M21-1            | 5M/T         | X                    |
|                | K34T                | 4D56-1 (2,5)  | X        | Enkel    | –                       | X                | Diesel            | V5M21-1            | 5M/T         | X                    |
|                | K36T                | 6G72-1 (3,0)  | –        | Dubbel   | X                       | –                | MPI               | V5MT1-2            | 5M/T         | X                    |
| L300           | P03V<br>P03W        | 4G63-3 (2,0)  | X        | Enkel    | X                       | –                | CARB              | R5M21-2<br>R4AW2-2 | 5M/T<br>4A/T | –<br>–               |
|                | P05V<br>P15V        | 4D56-1 (2,5)  | X        | Enkel    | –                       | –                | Diesel S-QGS      | R5M21-2<br>R4AW2-2 | 5M/T<br>4A/T | –<br>–               |



## 1991 modellen voor Australië

| Voertuig-<br>model | Voertuig<br>model-<br>code | Motor            |          |          |                                 |                           | Brand-<br>stof-<br>systeem | Versnellingsbak    |              |                               |
|--------------------|----------------------------|------------------|----------|----------|---------------------------------|---------------------------|----------------------------|--------------------|--------------|-------------------------------|
|                    |                            | Model<br>(liter) | Balansas | Nokkenas | Hydrau-<br>lische<br>klepstoter | Turbo-<br>compres-<br>sor |                            | Model              | Type         | Vierwiel-<br>aandrij-<br>ving |
| L300               | P04W                       | 4G64-1<br>(2,4)  | X        | Enkel    | X                               | –                         | MPI                        | R5M21-2<br>R4AW2-2 | 5M/T<br>4A/T | –<br>–                        |
| L300<br>4WD        | P24V<br>P24W               | 4G64-1<br>(2,4)  | X        | Enkel    | X                               | –                         | MPI                        | V5M21-2            | 5M/T         | X                             |
| Sigma              | F06A                       | 4G54-1<br>(2,6)  | X        | Enkel    | X                               | –                         | CARB                       | F5M31-2<br>F4A23-2 | 5M/T<br>4A/T | –<br>–                        |
|                    |                            |                  |          |          |                                 |                           | MPI                        | F5M31-2<br>F4A33-1 | 5M/T<br>4A/T | –<br>–                        |
|                    | F07A                       | 6G72-1<br>(3,0)  | –        | Dubbel   | X                               | –                         | MPI                        | F4A33-1            | 4A/T         | –                             |

1992 modellen voor Europa

| Voertuig-model | Voertuig-model-code | Motor         |          |          |                         |                  | Brandstofsysteem | Versnellingsbak    |              |                      |
|----------------|---------------------|---------------|----------|----------|-------------------------|------------------|------------------|--------------------|--------------|----------------------|
|                |                     | Model (liter) | Balansas | Nokkenas | Hydraulische klepstoter | Turbo-compressor |                  | Model              | Type         | Vierwiel-aandrijving |
| Colt           | CA1A                | 4G13-2 (1,3)  | –        | Enkel    | –                       | –                | MPI              | F5M21-1            | 5M/T         | –                    |
|                | CA4A                | 4G92-0 (1,6)  | –        | Enkel    | –                       | –                | MPI              | F5M22-2<br>F4A22-2 | 5M/T<br>4A/T | –<br>–               |
|                | CA5A                | 4G93-1 (1,8)  | –        | Dubbel   | X                       | –                | MPI              | F5M22-2            | 5M/T         | –                    |
|                | CC4A                | 4G92-0 (1,6)  | –        | Enkel    | –                       | –                | MPI              | W5M31-2            | 5M/T         | X                    |
| Space Runner   | N11W                | 4G93-0 (1,8)  | –        | Enkel    | –                       | –                | MPI              | F5M22-1<br>F4A22-2 | 5M/T<br>4A/T | –<br>–               |
|                | N21W                | 4G93-0 (1,8)  | –        | Enkel    | –                       | –                | MPI              | W5M31-2            | 5M/T         | X                    |
| Space Wagon    | N31W                | 4G93-0 (1,8)  | –        | Enkel    | –                       | –                | MPI              | F5M22-1<br>F4A22-2 | 5M/T<br>4A/T | –<br>–               |
|                | N35W                | 4D65-1 (1,8)  | X        | Enkel    | –                       | X                | Diesel           | F5M31-1            | 5M/T         | –                    |
|                | N41W                | 4G93-0 (1,8)  | –        | Enkel    | –                       | –                | MPI              | W5M31-2<br>W4A32-1 | 5M/T<br>4A/T | X<br>X               |
| Galant         | E31A                | 4G32-8 (1,6)  | –        | Enkel    | –                       | –                | CARB             | F5M21-1            | 5M/T         | –                    |
|                | E32A                | 4G37-7 (1,8)  | X        | Enkel    | –                       | –                | CARB             | F5M22-1<br>F4A21-2 | 5M/T<br>4A/T | –<br>–               |
|                |                     |               |          |          |                         |                  | MPI              | F5M22-1<br>F4A22-2 | 5M/T<br>4A/T | –<br>–               |
|                | E33A                | 4G63-3 (2,0)  | X        | Enkel    | X                       | –                | MPI              | F5M22-1<br>F4A22-2 | 5M/T<br>4A/T | –<br>–               |
|                |                     | 4G63-5 (2,0)  | X        | Dubbel   | X                       | –                | MPI              | F5M22-2            | 5M/T         | –                    |
|                | E34A                | 4D65-1 (1,8)  | X        | Enkel    | –                       | X                | Diesel S-QGS     | F5M31-1<br>F4A21-2 | 5M/T<br>4A/T | –<br>–               |
|                | E38A                | 4G63-3 (2,0)  | X        | Enkel    | X                       | –                | MPI              | W5M31-2            | 5M/T         | X                    |
|                | E39A                | 4G63-3 (2,0)  | X        | Enkel    | X                       | –                | MPI              | W5M31-2            | 5M/T         | X                    |
|                |                     | 4G63-5 (2,0)  | X        | Dubbel   | X                       | –                | MPI              | W5M31-2            | 5M/T         | X                    |

## 1992 modellen voor Europa

| Voertuig-<br>model | Voertuig<br>model-<br>code | Motor<br>Model<br>(liter) | Motor    |          |                                 |                           | Brand-<br>stof-<br>systeem | Vernellingsbak     |              |                               |
|--------------------|----------------------------|---------------------------|----------|----------|---------------------------------|---------------------------|----------------------------|--------------------|--------------|-------------------------------|
|                    |                            |                           | Balansas | Nokkenas | Hydrau-<br>lische<br>klepstoter | Turbo-<br>compres-<br>sor |                            | Model              | Type         | Vierwiel-<br>aandrij-<br>ving |
| L200               | K11T                       | 4G32-8<br>(1,6)           | –        | Enkel    | –                               | –                         | CARB                       | R5M21-1            | 5M/T         | –                             |
|                    | K12T                       | 4G63-3<br>(2,0)           | X        | Enkel    | X                               | –                         | CARB                       | R5M21-1            | 5M/T         | –                             |
|                    | K14T                       | 4D56-1<br>(2,5)           | X        | Enkel    | –                               | –                         | Diesel                     | R5M21-1            | 5M/T         | –                             |
| L200<br>4WD        | K22T<br>K32T               | 4G63-3<br>(2,0)           | X        | Enkel    | X                               | –                         | CARB                       | V5M21-1            | 5M/T         | X                             |
|                    | K24T<br>K34T               | 4D56-1<br>(2,5)           | X        | Enkel    | –                               | –                         | Diesel                     | V5M21-1            | 5M/T         | X                             |
|                    | K33T                       | G54B-1<br>(2,6)           | X        | Enkel    | X                               | –                         | ELEC.<br>CARB              | V5M21-1            | 5M/T         | X                             |
| L300               | P02V<br>P12V               | 4G32-8<br>(1,6)           | –        | Enkel    | –                               | –                         | CARB                       | R5M21-2            | 5M/T         | –                             |
|                    | L032P                      | 4G32-8<br>(1,6)           | –        | Enkel    | –                               | –                         | CARB                       | R5M21-3            | 5M/T         | –                             |
|                    | P03W                       | 4G63-3<br>(2,0)           | X        | Enkel    | X                               | –                         | CARB                       | R5M21-2<br>R4AW2-2 | 5M/T<br>4A/T | –<br>–                        |
|                    |                            |                           |          |          |                                 |                           | ELEC.<br>CARB              | R5M21-2            | 5M/T         | –                             |
|                    | P03V                       | 4G63-3<br>(2,0)           | X        | Enkel    | X                               | –                         | ELEC.<br>CARB              | R5M21-2            | 5M/T         | –                             |
|                    | P13V                       | 4G63-3<br>(2,0)           | X        | Enkel    | X                               | –                         | CARB                       | R5M21-2            | 5M/T         | –                             |
|                    |                            |                           |          |          |                                 |                           | ELEC.<br>CARB              | R5M21-2            | 5M/T         | –                             |
|                    | P04V<br>P04W<br>P14V       | 4G64-1<br>(2,4)           | X        | Enkel    | X                               | –                         | MPI                        | R5M21-2            | 5M/T         | –                             |
|                    | P05V<br>P05W<br>P15V       | 4D56-1<br>(2,5)           | X        | Enkel    | –                               | –                         | Diesel                     | R5M21-2            | 5M/T         | –                             |
|                    | L039P                      | 4D56-1<br>(2,5)           | X        | Enkel    | –                               | –                         | Diesel                     | R5M21-3            | 5M/T         | –                             |
| Diesel<br>S-QGS    |                            |                           |          |          |                                 |                           | R5M21-3                    | 5M/T               | –            |                               |

## 1992 modellen voor Europa

| Voertuig-<br>model | Voertuig<br>model-<br>code | Motor<br>Model<br>(liter) | Motor    |               |                                 |                           | Brand-<br>stof-<br>systeem | Versnellingsbak    |              |                               |
|--------------------|----------------------------|---------------------------|----------|---------------|---------------------------------|---------------------------|----------------------------|--------------------|--------------|-------------------------------|
|                    |                            |                           | Balansas | Nokkenas      | Hydrau-<br>lische<br>klepstoter | Turbo-<br>compres-<br>sor |                            | Model              | Type         | Vierwiel-<br>aandrij-<br>ving |
| L300<br>4WD        | P23V<br>P23W               | 4G63-3<br>(2,0)           | X        | Enkel         | X                               | –                         | ELEC.<br>CARB              | V5M21-2            | 5M/T         | X                             |
|                    | P24V<br>P24W               | 4G64-1<br>(2,4)           | X        | Enkel         | X                               | –                         | MPI                        | V5M21-2            | 5M/T         | X                             |
|                    | P25V<br>P25W<br>P45V       | 4D56-1<br>(2,5)           | X        | Enkel         | –                               | X                         | Diesel<br>S-QGS            | V5M21-2            | 5M/T         | X                             |
| Sigma              | F16A                       | 6G72-1<br>(3,0)           | –        | Dubbel        | X                               | –                         | MPI                        | F5M33-2<br>F4A33-1 | 5M/T<br>4A/T | –<br>–                        |
|                    |                            | 6G72-4<br>(3,0)           | –        | Dubbel<br>x 2 | X                               | –                         | MPI                        | F5M33-2<br>F4A33-1 | 5M/T<br>4A/T | –<br>–                        |

## 1992 modellen voor algemene export

| Voertuig-model | Voertuig-model-code | Motor         |          |          |                         |                  | Brandstof-systeem | Versnellingsbak    |              |                      |
|----------------|---------------------|---------------|----------|----------|-------------------------|------------------|-------------------|--------------------|--------------|----------------------|
|                |                     | Model (liter) | Balansas | Nokkenas | Hydraulische klepstoter | Turbo-compressor |                   | Model              | Type         | Vierwiel-aandrijving |
| Colt           | CA1A                | 4G13-2 (1,3)  | –        | Enkel    | –                       | –                | CARB              | F5M21-1            | 5M/T         | –                    |
|                | CB1A                | 4G13-2 (1,3)  | –        | Enkel    | –                       | –                | CARB              | F5M21-1<br>F3A21-2 | 5M/T<br>3A/T | –<br>–               |
|                |                     |               |          |          |                         |                  | ELEC.<br>CARB     | F5M21-1<br>F3A21-2 | 5M/T<br>3A/T | –<br>–               |
|                |                     |               |          |          |                         |                  | MPI               | F5M21-1            | 5M/T         | –                    |
|                | CA2A<br>CB2A        | 4G15-2 (1,5)  | –        | Enkel    | –                       | –                | CARB              | F5M21-1<br>F3A21-2 | 5M/T<br>3A/T | –<br>–               |
|                | CA4A<br>CB4A        | 4G92-0 (1,6)  | –        | Enkel    | –                       | –                | MPI               | F5M22-2<br>F4A22-2 | 5M/T<br>4A/T | –<br>–               |
| CA5A<br>CB5A   | 4G93-1 (1,8)        | –             | Dubbel   | X        | –                       | MPI              | F5M22-2           | 5M/T               | –            |                      |
| Space Runner   | N11W                | 4G93-0 (1,8)  | –        | Enkel    | –                       | –                | CARB              | F5M22-1<br>F4A22-2 | 5M/T<br>4A/T | –<br>–               |
|                |                     |               |          |          |                         |                  | MPI               | F5M22-1<br>F4A22-2 | 5M/T<br>4A/T | –<br>–               |
| Space Wagon    | N31W                | 4G93-0 (1,8)  | –        | Enkel    | –                       | –                | CARB              | F5M22-1<br>F4A22-2 | 5M/T<br>4A/T | –<br>–               |
|                |                     |               |          |          |                         |                  | MPI               | F5M22-1<br>F4A22-2 | 5M/T<br>4A/T | –<br>–               |
| Galant         | E31A                | 4G32-8 (1,6)  | –        | Enkel    | –                       | –                | CARB              | F5M21-1<br>F4A21-2 | 5M/T<br>4A/T | –<br>–               |
|                | E32A                | 4G37-7 (1,8)  | X        | Enkel    | –                       | –                | CARB              | F5M22-1<br>F4A21-2 | 5M/T<br>4A/T | –<br>–               |
|                |                     |               |          |          |                         |                  | MPI               | F5M22-1<br>F4A22-2 | 5M/T<br>4A/T | –<br>–               |
|                | E33A                | 4G63-3 (2,0)  | X        | Enkel    | –                       | –                | CARB              | F5M22-1<br>F4A22-2 | 5M/T<br>4A/T | –<br>–               |
|                |                     | 4G63-3 (2,0)  | X        | Enkel    | X                       | –                | MPI               | F5M22-1<br>F4A22-2 | 5M/T<br>4A/T | –<br>–               |
|                |                     | 4G63-5 (2,0)  | X        | Dubbel   | X                       | –                | MPI               | F5M22-2<br>F4A22-2 | 5M/T<br>4A/T | –<br>–               |
| E39A           | 4G63-5 (2,0)        | X             | Dubbel   | X        | X                       | MPI              | W5M33-2           | 5M/T               | X            |                      |

1992 modellen voor algemene export

| Voertuig-model | Voertuig-model-code          | Motor           |          |          |                         |                  | Brandstof-systeem | Versnellingsbak    |              |                      |
|----------------|------------------------------|-----------------|----------|----------|-------------------------|------------------|-------------------|--------------------|--------------|----------------------|
|                |                              | Model (liter)   | Balansas | Nokkenas | Hydraulische klepstoter | Turbo-compressor |                   | Model              | Type         | Vierwiel-aandrijving |
| Pajero         | V12C<br>V12V<br>V12W<br>V32V | 4G54-1<br>(2,6) | –        | Enkel    | –                       | –                | CARB              | V5M21-5            | 5M/T         | X                    |
|                | V14C<br>V14V<br>V34V         | 4D56-1<br>(2,5) | X        | Enkel    | –                       | –                | Diesel            | V5M21-5            | 5M/T         | X                    |
|                | V23W                         | 6G72-1<br>(3,0) | –        | Dubbel   | X                       | –                | MPI               | V5MT1-3            | 5M/T         | X                    |
|                | V24W<br>V44W                 | 4D56-1<br>(2,5) | X        | Enkel    | –                       | X                | Diesel            | V5MT1-3            | 5M/T         | X                    |
|                | V32W                         | 4G54-1<br>(2,6) | –        | Enkel    | –                       | –                | CARB              | V5MT1-3<br>V4AW2-3 | 5M/T<br>4A/T | X<br>X               |
|                | V43W                         | 6G72-1<br>(3,0) | –        | Dubbel   | X                       | –                | MPI               | V5MT1-3            | 5M/T         | X                    |
| L200           | K01T<br>K11T                 | 4G32-8<br>(1,6) | –        | Enkel    | –                       | –                | CARB              | R4M21-1            | 4M/T         | –                    |
|                | K02T<br>K12T                 | 4G63-4<br>(2,0) | –        | Enkel    | –                       | –                | CARB              | R5M21-1            | 5M/T         | –                    |
|                | K03T<br>K13T                 | 4G54-1<br>(2,6) | –        | Enkel    | –                       | –                | CARB              | R5M21-1            | 5M/T         | –                    |
|                | K14T                         | 4D56-1<br>(2,5) | X        | Enkel    | –                       | –                | Diesel            | R5M21-1            | 5M/T         | –                    |
| L200<br>4WD    | K22T<br>K32T                 | 4G63-4<br>(2,0) | –        | Enkel    | –                       | –                | CARB              | V5M21-1            | 5M/T         | X                    |
|                | K24T<br>K34T                 | 4D56-1<br>(2,5) | X        | Enkel    | –                       | –                | Diesel            | V5M21-1            | 5M/T         | X                    |
| L300           | P01V<br>P01W                 | 4G33-8<br>(1,4) | –        | Enkel    | –                       | –                | CARB              | R4M21-2            | 4M/T         | –                    |
|                | P02V<br>P12V<br>P12W         | 4G32-8<br>(1,6) | –        | Enkel    | –                       | –                | CARB              | R4M21-2            | 4M/T         | –                    |
|                | P03V<br>P13V<br>P13W         | 4G63-4<br>(2,0) | –        | Enkel    | –                       | –                | CARB              | R5M21-2            | 5M/T         | –                    |
|                | P03W                         | 4G63-4<br>(2,0) | –        | Enkel    | –                       | –                | CARB              | R5M21-2<br>R4AW2-2 | 5M/T<br>4A/T | –<br>–               |

## 1992 modellen voor algemene export

| Voertuig-model | Voertuig-model-code  | Motor           |          |               |                         |                  | Brandstof-systeem | Versnellingsbak    |              |                      |
|----------------|----------------------|-----------------|----------|---------------|-------------------------|------------------|-------------------|--------------------|--------------|----------------------|
|                |                      | Model (liter)   | Balansas | Nokkenas      | Hydraulische klepstoter | Turbo-compressor |                   | Model              | Type         | Vierwiel-aandrijving |
| L300           | P05V<br>P15V<br>P15W | 4D56-1<br>(2,5) | X        | Enkel         | –                       | –                | Diesel            | R5M21-2            | 5M/T         | –                    |
|                | P05W                 | 4D56-1<br>(2,5) | X        | Enkel         | –                       | –                | Diesel            | R5M21-2<br>R4AW2-2 | 5M/T<br>4A/T | –<br>–               |
| L300<br>4WD    | P23W                 | 4G63-4<br>(2,0) | –        | Enkel         | –                       | –                | CARB              | V5M21-2            | 5M/T         | X                    |
| Sigma          | F16A                 | 6G72-1<br>(3,0) | –        | Dubbel        | X                       | –                | MPI               | F5M33-2<br>F4A33-1 | 5M/T<br>4A/T | –<br>–               |
|                |                      | 6G72-4<br>(3,0) | –        | Dubbel<br>x 2 | X                       | –                | MPI               | F5M33-2<br>F4A33-1 | 5M/T<br>4A/T | –<br>–               |
| Diamante       | F26A                 | 6G72-4<br>(3,0) | –        | Dubbel<br>x 2 | X                       | –                | MPI               | W4A33-1            | 4A/T         | X                    |

## 1992 modellen voor Australië

| Voertuig-model | Voertuig-model-code | Motor         |          |          |                         |                  | Brandstof-systeem | Versnellingsbak    |              |                      |
|----------------|---------------------|---------------|----------|----------|-------------------------|------------------|-------------------|--------------------|--------------|----------------------|
|                |                     | Model (liter) | Balansas | Nokkenas | Hydraulische klepstoter | Turbo-compressor |                   | Model              | Type         | Vierwiel-aandrijving |
| Space Wagon    | N31W                | 4G64-1 (2,4)  | X        | Enkel    | X                       | –                | MPI               | F5M31-2<br>F4A23-2 | 5M/T<br>4A/T | –<br>–               |
| Galant         | E33A                | 4G63-3 (2,0)  | X        | Enkel    | X                       | –                | MPI               | F5M22-1<br>F4A22-2 | 5M/T<br>4A/T | –<br>–               |
|                |                     | 4G63-5 (2,0)  | X        | Dubbel   | X                       | –                | MPI               | F5M22-2<br>F4A22-2 | 5M/T<br>4A/T | –<br>–               |
|                | E39A                | 4G63-5 (2,0)  | X        | Dubbel   | X                       | X                | MPI               | W5M33-2            | 5M/T         | X                    |
| L200           | K13T                | 4G54-1 (2,6)  | X        | Enkel    | X                       | –                | CARB              | R5M21-1            | 5M/T         | –                    |
|                | K14T                | 4D56-1 (2,5)  | X        | Enkel    | –                       | –                | Diesel            | R5M21-1            | 5M/T         | –                    |
| L200 4WD       | K33T                | 4G54-1 (2,6)  | X        | Enkel    | X                       | –                | CARB              | V5M21-1            | 5M/T         | X                    |
|                | K34T                | 4D56-1 (2,5)  | X        | Enkel    | –                       | X                | Diesel            | V5M21-1            | 5M/T         | X                    |
|                | K36T                | 6G72-1 (3,0)  | –        | Dubbel   | X                       | –                | MPI               | V5MT1-2            | 5M/T         | X                    |
| L300           | P03V<br>P03W        | 4G63-3 (2,0)  | X        | Enkel    | X                       | –                | CARB              | R5M21-2<br>R4AW2-2 | 5M/T<br>4A/T | –<br>–               |
|                | P04W<br>P14V        | 4G64-1 (2,4)  | X        | Enkel    | X                       | –                | MPI               | R5M21-2<br>R4AW2-2 | 5M/T<br>4A/T | –<br>–               |
|                | P05V<br>P15V        | 4D56-1 (2,5)  | X        | Enkel    | –                       | –                | Diesel<br>S-QGS   | R5M21-2<br>R4AW2-2 | 5M/T<br>4A/T | –<br>–               |
| L300 4WD       | P24V<br>P24W        | 4G64-1 (2,4)  | X        | Enkel    | X                       | –                | MPI               | V5M21-2            | 5M/T         | X                    |



## 1993 modellen voor Europa

| Voertuig-model | Voertuig model-code | Motor         |          |          |                         |                  | Brandstof-systeem | Versnellingsbak    |              |                      |
|----------------|---------------------|---------------|----------|----------|-------------------------|------------------|-------------------|--------------------|--------------|----------------------|
|                |                     | Model (liter) | Balansas | Nokkenas | Hydraulische klepstoter | Turbo-compressor |                   | Model              | Type         | Vierwiel-aandrijving |
| Lancer         | CB1A                | 4G13-2 (1,3)  | –        | Enkel    | –                       | –                | MPI               | F5M21-1            | 5M/T         | –                    |
|                | CB4A<br>CB4W        | 4G92-0 (1,6)  | –        | Enkel    | –                       | –                | MPI               | F5M22-2<br>F4A22-2 | 5M/T<br>4A/T | –                    |
|                | CB5A                | 4G93-1 (1,8)  | –        | Dubbel   | X                       | –                | MPI               | F5M22-2            | 5M/T         | –                    |
|                | CB8A<br>CB8W        | 4D68-0 (2,0)  | X        | Enkel    | –                       | –                | Diesel S-QGS      | F5M22-1            | 5M/T         | –                    |
|                | CD4A<br>CD4W        | 4G92-0 (1,6)  | –        | Enkel    | –                       | –                | MPI               | W5M31-2            | 5M/T         | X                    |
|                | C61A                | 4G13-2 (1,3)  | –        | Enkel    | –                       | –                | CARB              | F5M21-1            | 5M/T         | –                    |
|                | C62A                | 4G15-2 (1,5)  | –        | Enkel    | –                       | –                | CARB              | F5M21-1<br>F3A21-2 | 5M/T<br>3A/T | –<br>–               |
|                | C66A                | 4G92-0 (1,6)  | –        | Enkel    | –                       | –                | MPI               | F5M22-2<br>F4A21-2 | 5M/T<br>4A/T | –<br>–               |
|                | C67A                | 4D68-0 (2,0)  | X        | Enkel    | –                       | –                | Diesel S-QGS      | F5M22-1            | 5M/T         | –                    |
|                | C69A                | 4G93-1 (1,8)  | –        | Dubbel   | X                       | –                | MPI               | F5M22-2            | 5M/T         | –                    |
|                | C76A                | 4G92-0 (1,6)  | –        | Enkel    | –                       | –                | MPI               | W5M31-2            | 5M/T         | X                    |
| Space Runner   | N11W                | 4G93-0 (1,8)  | –        | Enkel    | –                       | –                | MPI               | F5M22-1<br>F4A22-2 | 5M/T<br>4A/T | –<br>–               |
|                | N18W                | 4D68-0 (2,0)  | X        | Enkel    | –                       | X                | Diesel S-QGS      | F5M31-1            | 5M/T         | –                    |
|                | N21W                | 4G93-0 (1,8)  | –        | Enkel    | –                       | –                | MPI               | W5M31-2            | 5M/T         | X                    |
| Space Wagon    | N33W                | 4G63-6 (2,0)  | X        | Enkel    | X                       | –                | MPI               | F5M22-1<br>F4A22-2 | 5M/T<br>4A/T | –<br>–               |
|                | N34W                | 4G64-2 (2,4)  | X        | Enkel    | X                       | –                | MPI               | F5M31-2<br>F4A23-2 | 5M/T<br>4A/T | –<br>–               |
|                | N38W                | 4D68-0 (2,0)  | X        | Enkel    | –                       | X                | Diesel S-QGS      | F5M31-1            | 5M/T         | –                    |
|                | N43W                | 4G63-6 (2,0)  | X        | Enkel    | X                       | –                | MPI               | W5M31-2<br>F4A32-1 | 5M/T<br>4A/T | X<br>X               |

## 1993 modellen voor Europa

| Voertuig-model     | Voertuig-model-code  | Motor           |          |          |                         |                  | Brandstof-systeem | Versnellingsbak    |              |                      |
|--------------------|----------------------|-----------------|----------|----------|-------------------------|------------------|-------------------|--------------------|--------------|----------------------|
|                    |                      | Model (liter)   | Balansas | Nokkenas | Hydraulische klepstoter | Turbo-compressor |                   | Model              | Type         | Vierwiel-aandrijving |
| Galant             | E52A                 | 4G93-0<br>(1,8) | –        | Enkel    | –                       | –                | MPI               | F5M22-2<br>F4A22-2 | 5M/T<br>4A/T | –<br>–               |
|                    | E54A                 | 6A12-0<br>(2,0) | –        | Vier     | X                       | –                | MPI               | F5M31-2<br>F4A23-2 | 5M/T<br>4A/T | –<br>–               |
|                    | E55A                 | 4G63-6<br>(2,0) | X        | Enkel    | X                       | –                | MPI               | F5M22-2<br>F4A22-2 | 5M/T<br>4A/T | –<br>–               |
|                    | E57A                 | 4D68-0<br>(2,0) | X        | Enkel    | –                       | X                | Diesel<br>S-QGS   | F5M31-1            | 5M/T         | –                    |
|                    | E64A                 | 6A12-0<br>(2,0) | –        | Vier     | X                       | –                | MPI               | F5M31-2<br>F4A23-2 | 5M/T<br>4A/T | –<br>–               |
|                    | E75A                 | 4G63-6<br>(2,0) | X        | Enkel    | X                       | –                | MPI               | W5M31-2            | 5M/T         | X                    |
|                    | E88A                 | 6G73-1<br>(2,5) | –        | Vier     | X                       | –                | MPI               | W5M33-2            | 5M/T         | X                    |
| Pajero/<br>Montero | V21C<br>V21W<br>V41W | 4G64-3<br>(2,4) | X        | Enkel    | X                       | –                | MPI               | V5M21-5            | 5M/T         | X                    |
|                    | V23C                 | 6G72-1<br>(3,0) | –        | Dubbel   | X                       | –                | MPI               | V4AW2-3            | 4A/T         | X                    |
|                    | V23W<br>V43W         | 6G72-1<br>(3,0) | –        | Dubbel   | X                       | –                | MPI               | V5MT1-3<br>V4AW2-3 | 5M/T<br>4A/T | X<br>X               |
|                    | V24C<br>V24W         | 4D56-1<br>(2,5) | X        | Enkel    | –                       | X                | Diesel            | V5MT1-3            | 5M/T         | X                    |
|                    | V44W                 | 4D56-1<br>(2,5) | X        | Enkel    | –                       | X                | Diesel            | V5MT1-3<br>V4AW2-3 | 5M/T<br>4A/T | X<br>X               |
| L200               | K11T                 | 4G32-8<br>(1,6) | –        | Enkel    | –                       | –                | CARB              | R5M21-1            | 5M/T         | –                    |
|                    | K12T                 | 4G63-9<br>(2,0) | X        | Enkel    | X                       | –                | CARB              | R5M21-1            | 5M/T         | –                    |
|                    | K14T                 | 4D56-1<br>(2,5) | X        | Enkel    | –                       | –                | Diesel            | R5M21-1            | 5M/T         | –                    |
| L200<br>4WD        | K22T<br>K32T         | 4G63-9<br>(2,0) | X        | Enkel    | X                       | –                | CARB              | V5M21-1            | 5M/T         | X                    |
|                    | K24T<br>K34T         | 4D56-1<br>(2,5) | X        | Enkel    | –                       | X                | Diesel            | V5M21-1            | 5M/T         | X                    |
|                    | K33T                 | G54B-1<br>(2,6) | X        | Enkel    | X                       | –                | CARB              | V5M21-1            | 5M/T         | X                    |
| L300               | P02V<br>P12V         | 4G32-8<br>(1,6) | –        | Enkel    | –                       | –                | CARB              | R5M21-2            | 5M/T         | –                    |
|                    | P03V                 | 4G63-9<br>(2,0) | X        | Enkel    | X                       | –                | ELEC.<br>CARB     | R5M21-2            | 5M/T         | –                    |

## 1993 modellen voor Europa

| Voertuig-<br>model   | Voertuig<br>model-<br>code | Motor            |          |          |                                 |                           | Brand-<br>stof-<br>systeem | Versnellingsbak      |                 |                               |        |   |      |                 |         |      |   |
|----------------------|----------------------------|------------------|----------|----------|---------------------------------|---------------------------|----------------------------|----------------------|-----------------|-------------------------------|--------|---|------|-----------------|---------|------|---|
|                      |                            | Model<br>(liter) | Balansas | Nokkenas | Hydrau-<br>lische<br>klepstoter | Turbo-<br>compres-<br>sor |                            | Model                | Type            | Vierwiel-<br>aandrij-<br>ving |        |   |      |                 |         |      |   |
| L300                 | P03W                       | 4G63-9<br>(2,0)  | X        | Enkel    | X                               | –                         | CARB                       | R5M21-2              | 5M/T            | –                             |        |   |      |                 |         |      |   |
|                      |                            |                  |          |          |                                 |                           |                            | R4AW2-2              | 4A/T            | –                             |        |   |      |                 |         |      |   |
|                      | P13V                       | 4G63-9<br>(2,0)  | X        | Enkel    | X                               | –                         | CARB                       | R5M21-2              | 5M/T            | –                             |        |   |      |                 |         |      |   |
|                      |                            |                  |          |          |                                 |                           |                            | ELEC.<br>CARB        | R5M21-2         | 5M/T                          | –      |   |      |                 |         |      |   |
|                      | P04V<br>P04W<br>P14V       | 4G64-3<br>(2,4)  | X        | Enkel    | X                               | –                         | MPI                        | R5M21-2              | 5M/T            | –                             |        |   |      |                 |         |      |   |
|                      |                            |                  |          |          |                                 |                           |                            | ELEC.<br>CARB        | R5M21-2         | 5M/T                          | –      |   |      |                 |         |      |   |
| P05V<br>P05W<br>P15V | 4D56-1<br>(2,5)            | X                | Enkel    | –        | –                               | Diesel                    | R5M21-2                    | 5M/T                 | –               |                               |        |   |      |                 |         |      |   |
|                      |                            |                  |          |          |                                 |                           | L032P                      | 4G32-8<br>(1,6)      | –               | Enkel                         | –      | – | CARB | R5M21-3         | 5M/T    | –    |   |
| L039P                | 4D56-1<br>(2,5)            | X                | Enkel    | –        | –                               | Diesel                    | R5M21-3                    | 5M/T                 | –               |                               |        |   |      |                 |         |      |   |
|                      |                            |                  |          |          |                                 |                           | Diesel<br>S-QGS            | R5M21-3              | 5M/T            | –                             |        |   |      |                 |         |      |   |
| L300<br>4WD          | P24V<br>P24W               | 4G64-3<br>(2,4)  | X        | Enkel    | X                               | –                         | MPI                        | V5M21-2              | 5M/T            | X                             |        |   |      |                 |         |      |   |
|                      |                            |                  |          |          |                                 |                           |                            | P25V<br>P25W<br>P45W | 4D56-1<br>(2,5) | X                             | Enkel  | – | X    | Diesel<br>S-QGS | V5M21-2 | 5M/T | X |
| Sigma                | F16A                       | 6G72-1           | –        | Dubbel   | X                               | –                         | MPI                        | F5M33-2              | 5M/T            | –                             |        |   |      |                 |         |      |   |
|                      |                            |                  |          |          |                                 |                           |                            | F4A33-1              | 4A/T            | –                             |        |   |      |                 |         |      |   |
| 3000GT               | Z16A                       | 6G72-4           | –        | Vier     | X                               | X                         | MPI                        | F5M33-2              | 5M/T            | –                             |        |   |      |                 |         |      |   |
|                      |                            |                  |          |          |                                 |                           |                            | F4A33-1              | 4A/T            | –                             |        |   |      |                 |         |      |   |
| Eclipse              | D22A                       | 4G63-7           | X        | Dubbel   | X                               | –                         | MPI                        | F5M31-2              | 5M/T            | –                             |        |   |      |                 |         |      |   |
|                      |                            |                  |          |          |                                 |                           |                            | D27A                 | 4G63-7          | X                             | Dubbel | X | –    | MPI             | W5M33-2 | 5M/T | X |
| Colt                 | CA1A                       | 4G13-2<br>(1,3)  | –        | Enkel    | –                               | –                         | CARB                       | F5M21-1              | 5M/T            | –                             |        |   |      |                 |         |      |   |
|                      |                            |                  |          |          |                                 |                           |                            | CA2A                 | 4G15-2<br>(1,5) | –                             | Enkel  | – | –    | CARB            | F5M21-1 | 5M/T | – |
|                      |                            |                  |          |          |                                 |                           |                            | F3A21-2              | 3A/T            | –                             |        |   |      |                 |         |      |   |
| Lancer               | CA5A                       | 4G93-1<br>(1,8)  | –        | Dubbel   | X                               | –                         | MPI                        | F5M22-2              | 5M/T            | –                             |        |   |      |                 |         |      |   |
|                      |                            |                  |          |          |                                 |                           |                            | CB1A                 | 4G13-2<br>(1,3) | –                             | Enkel  | – | –    | CARB            | F5M21-1 | 5M/T | – |
| CB1W                 | 4G13-2<br>(1,3)            | –                | Enkel    | –        | –                               | CARB                      | F5M21-1                    |                      |                 |                               |        |   |      |                 | 5M/T    | –    |   |
|                      |                            |                  |          |          |                                 |                           | F3A21-2                    | 3A/T                 | –               |                               |        |   |      |                 |         |      |   |

1993 modellen voor algemene export

| Voertuig-model     | Voertuig model-code | Motor           |          |          |                         |                  | Brandstof-systeem | Versnellingsbak |         |                      |   |
|--------------------|---------------------|-----------------|----------|----------|-------------------------|------------------|-------------------|-----------------|---------|----------------------|---|
|                    |                     | Model (liter)   | Balansas | Nokkenas | Hydraulische klepstoter | Turbo-compressor |                   | Model           | Type    | Vierwiel-aandrijving |   |
| Lancer             | CB2A                | 4G15-2<br>(1,5) | -        | Enkel    | -                       | -                | CARB              | F5M21-1         | 5M/T    | -                    |   |
|                    | CB2W                |                 |          |          |                         |                  |                   | F3A21-2         | 3A/T    | -                    |   |
|                    | CB4W                | 4G92-0<br>(1,6) | -        | Enkel    | -                       | -                | MPI               | F5M22-2         | 5M/T    | -                    |   |
| Space Runner       | N11W                | 4G93-0<br>(1,8) | -        | Enkel    | -                       | -                | CARB              | F5M22-1         | 5M/T    | -                    |   |
|                    |                     |                 |          |          |                         |                  |                   | F4A22-2         | 4A/T    | -                    |   |
|                    |                     |                 |          |          |                         |                  | MPI               | F5M22-1         | 5M/T    | -                    |   |
|                    |                     |                 |          |          |                         |                  |                   | F4A22-2         | 4A/T    | -                    |   |
| Space Wagon        | N31W                | 4G93-0<br>(1,8) | -        | Enkel    | -                       | -                | CARB              | F5M22-1         | 5M/T    | -                    |   |
|                    |                     |                 |          |          |                         |                  |                   | F4A22-2         | 4A/T    | -                    |   |
|                    |                     |                 |          |          |                         |                  | MPI               | F5M22-1         | 5M/T    | -                    |   |
|                    |                     |                 |          |          |                         |                  |                   | F4A22-2         | 4A/T    | -                    |   |
| Galant             | E52A                | 4G93-0<br>(1,8) | -        | Enkel    | -                       | -                | CARB              | F5M22-2         | 5M/T    | -                    |   |
|                    |                     |                 |          |          |                         |                  |                   | F4A22-2         | 4A/T    | -                    |   |
|                    |                     |                 |          |          |                         |                  |                   | MPI             | F5M22-2 | 5M/T                 | - |
|                    |                     |                 |          |          |                         |                  |                   |                 | F4A22-2 | 4A/T                 | - |
|                    | E54A                | 6A12-0<br>(2,0) | -        | Dubbel   | X                       | -                | MPI               | F5M31-2         | 5M/T    | -                    |   |
|                    |                     |                 |          |          |                         |                  |                   | F5A23-2         | 4A/T    | -                    |   |
|                    | E55A                | 4G63-6<br>(2,0) | X        | Enkel    | X                       | -                | CARB              | F5M22-2         | 5M/T    | -                    |   |
|                    |                     |                 |          |          |                         |                  |                   | F4A22-2         | 4A/T    | -                    |   |
|                    |                     |                 |          |          |                         |                  | MPI               | F4A22-2         | 4A/T    | -                    |   |
| Pajero/<br>Montero | V12C                | 4G54-1<br>(2,6) | -        | Enkel    | -                       | -                | CARB              | V5M21-5         | 5M/T    | X                    |   |
|                    | V12V                |                 |          |          |                         |                  |                   | V4AW2-3         | 4A/T    | X                    |   |
|                    | V12W                |                 |          |          |                         |                  |                   |                 |         |                      |   |
|                    | V32V                |                 |          |          |                         |                  |                   |                 |         |                      |   |
|                    | V32W                | 4G54-1<br>(2,6) | -        | Enkel    | -                       | -                | CARB              | V5M21-5         | 5M/T    | X                    |   |

## 1993 modellen voor algemene export

| Voertuig-<br>model | Voertuig<br>model-<br>code | Motor            |          |          |                                 |                           | Brand-<br>stof-<br>systeem | Versnellingsbak    |              |                               |
|--------------------|----------------------------|------------------|----------|----------|---------------------------------|---------------------------|----------------------------|--------------------|--------------|-------------------------------|
|                    |                            | Model<br>(liter) | Balansas | Nokkenas | Hydrau-<br>lische<br>klepstoter | Turbo-<br>compres-<br>sor |                            | Model              | Type         | Vierwiel-<br>aandrij-<br>ving |
| Pajero/<br>Montero | V23W<br>V43W               | 6G72-1<br>(3,0)  | –        | Dubbel   | X                               | –                         | MPI                        | V5MT1-3<br>V4AW2-3 | 5M/T<br>4A/T | X<br>X                        |
|                    | V14C<br>V14V<br>V34V       | 4D56-1<br>(2,5)  | X        | Enkel    | –                               | –                         | Diesel                     | V5M21-5            | 5M/T         | X                             |
|                    | V34V                       | 4D56-1<br>(2,5)  | X        | Enkel    | –                               | X                         | Diesel                     | V5M21-5            | 5M/T         | X                             |
|                    | V24W<br>V34W               | 4D56-1<br>(2,5)  | X        | Enkel    | –                               | X                         | Diesel                     | V5MT1-3            | 5M/T         | X                             |
|                    | V44W                       | 4D56-1<br>(2,5)  | X        | Enkel    | –                               | X                         | Diesel                     | V5MT1-3<br>V4AW2-3 | 5M/T<br>4A/T | X<br>X                        |
| L200               | K01T<br>K11T               | 4G32-8<br>(1,6)  | –        | Enkel    | –                               | –                         | CARB                       | R4M21-1            | 4M/T         | –                             |
|                    | K02T<br>K12T               | 4G63-8<br>(2,0)  | –        | Enkel    | –                               | –                         | CARB                       | R5M21-1            | 5M/T         | –                             |
|                    | K03T<br>K13T               | 4G54-1<br>(2,6)  | –        | Enkel    | –                               | –                         | CARB                       | R5M21-1            | 5M/T         | –                             |
|                    | K14T                       | 4D56-1<br>(2,5)  | X        | Enkel    | –                               | –                         | Diesel                     | R5M21-1            | 5M/T         | –                             |
| L200<br>4WD        | K22T<br>K32T               | 4G63-8<br>(2,0)  | –        | Enkel    | –                               | –                         | CARB                       | V5M21-1            | 5M/T         | X                             |
|                    | K24T<br>K34T               | 4D56-1<br>(2,5)  | X        | Enkel    | –                               | –                         | Diesel                     | V5M21-1            | 5M/T         | X                             |
| L300               | P01V                       | 4G33-8<br>(1,4)  | –        | Enkel    | –                               | –                         | CARB                       | R4M21-2            | 4M/T         | –                             |
|                    |                            | G33B-8<br>(1,4)  | –        | Enkel    | –                               | –                         | CARB                       | R4M21-2            | 4M/T         | –                             |
|                    | P01W                       | 4G33-8<br>(1,4)  | –        | Enkel    | –                               | –                         | CARB                       | R4M21-2            | 4M/T         | –                             |
|                    | P12V<br>P12W               | 4G32-8<br>(1,6)  | –        | Enkel    | –                               | –                         | CARB                       | R4M21-2            | 4M/T         | –                             |
|                    | P03V<br>P13V<br>P13W       | 4G63-8<br>(2,0)  | –        | Enkel    | –                               | –                         | CARB                       | R5M21-2            | 5M/T         | –                             |
|                    | P03W                       | 4G63-8<br>(2,0)  | –        | Enkel    | –                               | –                         | CARB                       | R5M21-2<br>R4AW2-2 | 5M/T<br>4A/T | –<br>–                        |
|                    | P04W                       | 4G64-3<br>(2,4)  | X        | Enkel    | X                               | –                         | MPI                        | R4AW2-2            | 4A/T         | –                             |

## 1993 modellen voor algemene export

| Voertuig-model | Voertuig-model-code  | Motor           |          |          |                         |                  | Brandstof-systeem | Versnellingsbak    |              |                      |
|----------------|----------------------|-----------------|----------|----------|-------------------------|------------------|-------------------|--------------------|--------------|----------------------|
|                |                      | Model (liter)   | Balansas | Nokkenas | Hydraulische klepstoter | Turbo-compressor |                   | Model              | Type         | Vierwiel-aandrijving |
| L300           | P05V<br>P15V<br>P15W | 4D56-1<br>(2,5) | X        | Enkel    | –                       | –                | Diesel            | R5M21-2            | 5M/T         | –                    |
|                | P05W                 | 4D56-1<br>(2,5) | X        | Enkel    | –                       | –                | Diesel            | R5M21-2            | 5M/T         | –                    |
| L300<br>4WD    | P23W                 | 4G63-8<br>(2,0) | –        | Enkel    | –                       | –                | CARB              | V5M21-2            | 5M/T         | X                    |
|                | P24W                 | 4G64-3<br>(2,4) | X        | Enkel    | X                       | –                | MPI               | V5M21-2            | 5M/T         | X                    |
| Sigma          | F16A                 | 6G72-1<br>(3,0) | –        | Dubbel   | X                       | –                | MPI               | F5M33-2<br>F4A33-1 | 5M/T<br>4A/T | –<br>–               |
|                |                      | 6G72-4<br>(3,0) | –        | Vier     | X                       | –                | MPI               | F5M33-2<br>F4A33-1 | 5M/T<br>4A/T | –<br>–               |
| Diamante       | F26A                 | 6G72-4<br>(3,0) | –        | Vier     | X                       | –                | MPI               | W4A33-1            | 4A/T         | X                    |
| 3000GT         | Z16A                 | 6G72-4<br>(3,0) | –        | Vier     | X                       | X                | MPI               | W5MG1-2            | 5M/T         | X                    |

## 1993 modellen voor Australië

| Voertuig-model     | Voertuig-model-code  | Motor           |          |          |                         |                  | Brandstof-systeem | Versnellingsbak    |              |                      |
|--------------------|----------------------|-----------------|----------|----------|-------------------------|------------------|-------------------|--------------------|--------------|----------------------|
|                    |                      | Model (liter)   | Balansas | Nokkenas | Hydraulische klepstoter | Turbo-compressor |                   | Model              | Type         | Vierwiel-aandrijving |
| Lancer             | CA2A<br>CB2A         | 4G15-2<br>(1,5) | –        | Enkel    | –                       | –                | CARB              | F5M21-1<br>F3A21-2 | 5M/T<br>3A/T | –<br>–               |
|                    | CA5A<br>CB5A<br>CB5W | 4G93-0<br>(1,8) | –        | Enkel    | –                       | –                | MPI               | F5M22-2<br>F4A22-2 | 5M/T<br>4A/T | –<br>–               |
|                    | CD5A                 | 4G93-1<br>(1,8) | –        | Dubbel   | X                       | X                | MPI               | W5M33-2            | 5M/T         | X                    |
|                    | C62A                 | 4G15-2<br>(1,5) | –        | Enkel    | –                       | –                | CARB              | F5M21-1<br>F3A21-2 | 5M/T<br>3A/T | –<br>–               |
|                    | C66A                 | 4G92-0<br>(1,6) | –        | Enkel    | –                       | –                | MPI               | F5M22-2<br>F4A21-2 | 5M/T<br>4A/T | –<br>–               |
| Space Wagon        | N34W                 | 4G64-2<br>(2,4) | X        | Enkel    | X                       | –                | MPI               | F5M31-2<br>F4A23-2 | 5M/T<br>4A/T | –<br>–               |
| Galant             | E54A                 | 6A12-0<br>(2,0) | –        | Vier     | X                       | –                | MPI               | F5M31-2<br>F4A23-2 | 5M/T<br>4A/T | –<br>–               |
|                    | E55A                 | 4G63-6<br>(2,0) | X        | Enkel    | X                       | –                | MPI               | F5M22-2<br>F4A22-2 | 5M/T<br>4A/T | –<br>–               |
| Pajero/<br>Montero | V12W<br>V32W         | 4G54-1<br>(2,6) | X        | Enkel    | X                       | –                | CARB              | V5M21-5            | 5M/T         | X                    |
|                    | V23W                 | 6G72-1<br>(3,0) | –        | Enkel    | X                       | –                | MPI               | V5MT1-3            | 5M/T         | X                    |
|                    | V43W                 | 6G72-1<br>(3,0) | –        | Enkel    | X                       | –                | MPI               | V5MT1-3<br>V4AW2-3 | 5M/T<br>3A/T | X<br>X               |
|                    | V34W                 | 4D56-1<br>(2,5) | X        | Enkel    | –                       | X                | Diesel            | V5M21-5            | 5M/T         | X                    |
|                    | V44W                 | 4D56-1<br>(2,5) | X        | Enkel    | –                       | X                | Diesel            | V5MT1-3            | 5M/T         | X                    |
| L200               | K13T                 | 4G54-1<br>(2,6) | X        | Enkel    | X                       | –                | CARB              | R5M21-1            | 5M/T         | –                    |
|                    | K14T                 | 4D56-1<br>(2,5) | X        | Enkel    | –                       | –                | Diesel            | R5M21-1            | 5M/T         | –                    |
| L200<br>4WD        | K33T                 | 4G54-1<br>(2,6) | X        | Enkel    | X                       | –                | CARB              | R5M21-1            | 5M/T         | X                    |
|                    | K34T                 | 4D56-1<br>(2,5) | X        | Enkel    | –                       | X                | Diesel            | R5M21-1            | 5M/T         | X                    |
|                    | K36T                 | 6G72-1<br>(3,0) | –        | Dubbel   | X                       | –                | MPI               | V5MT1-2            | 5M/T         | X                    |

## 1993 modellen voor Australië

| Voertuig-model | Voertuig-model-code | Motor           |          |          |                         |                  | Brandstof-systeem | Versnellingsbak    |              |                      |
|----------------|---------------------|-----------------|----------|----------|-------------------------|------------------|-------------------|--------------------|--------------|----------------------|
|                |                     | Model (liter)   | Balansas | Nokkenas | Hydraulische klepstoter | Turbo-compressor |                   | Model              | Type         | Vierwiel-aandrijving |
| L300           | P03V<br>P03W        | 4G63-9<br>(2,0) | X        | Enkel    | X                       | –                | CARB              | R5M21-2<br>R4AW2-2 | 5M/T<br>4A/T | –<br>–               |
|                | P04W<br>P14V        | 4G64-3<br>(2,4) | X        | Enkel    | X                       | –                | MPI               | R5M21-2<br>R4AW2-2 | 5M/T<br>4A/T | –<br>–               |
|                | P05V<br>P15V        | 4D56-1<br>(2,5) | X        | Enkel    | –                       | –                | Diesel<br>S-QGS   | R5M21-2<br>R4AW2-2 | 5M/T<br>4A/T | –<br>–               |
| L300<br>4WD    | P24V<br>P24W        | 4G64-3<br>(2,4) | X        | Enkel    | X                       | –                | MPI               | V5M21-2            | 5M/T         | X                    |
| 3000GT         | Z16A                | 6G72-4<br>(3,0) | –        | Vier     | X                       | X                | MPI               | W5MG1-1            | 5M/T         | X                    |



## 1994 modellen voor Europa

| Voertuig-<br>model         | Voertuig<br>model-<br>code | Motor            |          |          |                                 |                           | Brand-<br>stof-<br>systeem | Versnellingsbak    |              |                               |
|----------------------------|----------------------------|------------------|----------|----------|---------------------------------|---------------------------|----------------------------|--------------------|--------------|-------------------------------|
|                            |                            | Model<br>(liter) | Balansas | Nokkenas | Hydrau-<br>lische<br>klepstoter | Turbo-<br>compres-<br>sor |                            | Model              | Type         | Vierwiel-<br>aandrij-<br>ving |
| Colt                       | CA1A                       | 4G13-2<br>(1,3)  | –        | Enkel    | –                               | –                         | MPI                        | F5M21-1            | 5M/T         | –                             |
|                            | CA4A                       | 4G92-0<br>(1,6)  | –        | Enkel    | –                               | –                         | MPI                        | F5M22-2<br>F4A22-2 | 5M/T<br>4A/T | –<br>–                        |
|                            | CA5A                       | 4G93-1<br>(1,8)  | –        | Dubbel   | X                               | –                         | MPI                        | F5M22-2            | 5M/T         | –                             |
|                            | CC4A                       | 4G92-0<br>(1,6)  | –        | Enkel    | –                               | –                         | MPI                        | W5M31-2            | 5M/T         | X                             |
| Lancer/<br>Lancer<br>Wagon | CB1A                       | 4G13-2<br>(1,3)  | –        | Enkel    | –                               | –                         | MPI                        | F5M21-1            | 5M/T         | –                             |
|                            | CB4A<br>CB4W               | 4G92-0<br>(1,6)  | –        | Enkel    | –                               | –                         | MPI                        | F5M22-2<br>F4A22-2 | 5M/T<br>4A/T | –<br>–                        |
|                            | CB5A                       | 4G93-1<br>(1,8)  | –        | Dubbel   | X                               | –                         | MPI                        | F5M22-2            | 5M/T         | –                             |
|                            | CB8A<br>CB8W               | 4D68-0<br>(2,0)  | X        | Enkel    | –                               | –                         | Diesel<br>S-RGS            | F5M22-1            | 5M/T         | –                             |
|                            | CD4A<br>CD4W               | 4G92-0<br>(1,6)  | –        | Enkel    | –                               | –                         | MPI                        | W5M31-2            | 5M/T         | X                             |
|                            | C61A                       | 4G13-2<br>(1,3)  | –        | Enkel    | –                               | –                         | MPI                        | F5M21-1            | 5M/T         | –                             |
|                            | C66A                       | 4G92-0<br>(1,6)  | –        | Enkel    | –                               | –                         | MPI                        | F5M22-2<br>F4A21-2 | 5M/T<br>4A/T | –<br>–                        |
|                            | C67A                       | 4D68-0<br>(2,0)  | X        | Enkel    | –                               | –                         | Diesel<br>S-RGS            | F5M22-1            | 5M/T         | –                             |
|                            | C69A                       | 4G93-1<br>(1,8)  | –        | Dubbel   | X                               | –                         | MPI                        | F5M22-2            | 5M/T         | –                             |
|                            | C76A                       | 4G92-0<br>(1,6)  | –        | Enkel    | –                               | –                         | MPI                        | W5M31-2            | 5M/T         | X                             |
| Space<br>Runner            | N11W                       | 4G93-0<br>(1,8)  | –        | Enkel    | –                               | –                         | MPI                        | F5M22-1<br>F4A22-2 | 5M/T<br>4A/T | –<br>–                        |
|                            | N18W                       | 4D68-0<br>(2,0)  | X        | Enkel    | –                               | X                         | Diesel<br>S-RGS            | F5M31-1            | 5M/T         | –                             |
|                            | N21W                       | 4G93-0<br>(1,8)  | –        | Enkel    | –                               | –                         | MPI                        | W5M31-2            | 5M/T         | X                             |

## 1994 modellen voor Europa

| Voertuig-model     | Voertuig-model-code | Motor         |          |          |                         |                  | Brandstof-systeem | Vernellingsbak     |              |                      |
|--------------------|---------------------|---------------|----------|----------|-------------------------|------------------|-------------------|--------------------|--------------|----------------------|
|                    |                     | Model (liter) | Balansas | Nokkenas | Hydraulische klepstoter | Turbo-compressor |                   | Model              | Type         | Vierwiel-aandrijving |
| Space Wagon        | N33W                | 4G63-6 (2,0)  | X        | Enkel    | X                       | –                | MPI               | F5M22-1<br>F4A22-2 | 5M/T<br>4A/T | --<br>--             |
|                    | N34W                | 4G64-2 (2,4)  | X        | Enkel    | X                       | –                | MPI               | F5M22-1<br>F4A23-2 | 5M/T<br>4A/T | --<br>--             |
|                    | N38W                | 4D68-0 (2,0)  | X        | Enkel    | –                       | X                | Diesel S-RGS      | F5M31-1            | 5M/T         | --                   |
|                    | N43W                | 4G63-6 (2,0)  | X        | Enkel    | X                       | –                | MPI               | W5M31-2<br>W4A32-1 | 5M/T<br>4A/T | X<br>X               |
| Galant             | E52A                | 4G93-0 (1,8)  | –        | Enkel    | –                       | –                | MPI               | F5M22-2<br>F4A22-2 | 5M/T<br>4A/T | --<br>--             |
|                    | E54A<br>E64A        | 6A12-0 (2,0)  | –        | Vier     | X                       | –                | MPI               | F5M31-2<br>F4A23-2 | 5M/T<br>4A/T | --<br>--             |
|                    | E55A                | 4G63-6 (2,0)  | X        | Enkel    | X                       | –                | MPI               | F5M22-2<br>F4A22-2 | 5M/T<br>4A/T | --<br>--             |
|                    | E57A                | 4D68-0 (2,0)  | X        | Enkel    | –                       | X                | Diesel S-RGS      | F5M31-1            | 5M/T         | --                   |
|                    | E75A                | 4G63-6 (2,0)  | X        | Enkel    | X                       | –                | MPI               | W5M31-2            | 5M/T         | X                    |
|                    | E88A                | 6G73-1 (2,5)  | –        | Vier     | X                       | –                | MPI               | W5M33-2            | 5M/T         | X                    |
|                    | E99A                | 420B-0 (2,0)  | –        | Dubbel   | X                       | –                | MPI               | F5MC1-1<br>F4AC1-1 | 5M/T<br>4A/T | --<br>--             |
| Pajero/<br>Montero | V21W                | 4G64-3 (2,4)  | X        | Enkel    | X                       | –                | MPI               | V5M21-6            | 5M/T         | X                    |
|                    | V23C                | 6G72-1 (3,0)  | –        | Dubbel   | X                       | –                | MPI               | V4AW2-7            | 4A/T         | X                    |
|                    | V23W<br>V43W        | 6G72-1 (3,0)  | –        | Dubbel   | X                       | –                | MPI               | V5MT1-6<br>V4AW2-7 | 5M/T<br>4A/T | X<br>X               |
|                    | V24C<br>V24W        | 4D56-1 (2,5)  | X        | Enkel    | –                       | X                | Diesel S-RGS      | V5MT1-6            | 5M/T         | X                    |
|                    | V25W<br>V45W        | 6G74-1 (3,5)  | –        | Vier     | X                       | –                | MPI               | V5M31-5<br>V4AW3-7 | 5M/T<br>4A/T | X<br>X               |
|                    | V46W                | 4M40 (2,8)    | X        | Enkel    | –                       | X                | Diesel S-RGS      | V5M31-5<br>V4AW3-7 | 5M/T<br>4A/T | X<br>X               |
| L200               | K11T                | 4G32-8 (1,6)  | –        | Enkel    | –                       | –                | CARB              | R5M21-1            | 5M/T         | --                   |
|                    | K12T                | 4G63-9 (2,0)  | X        | Enkel    | X                       | –                | CARB              | R5M21-1            | 5M/T         | --                   |
|                    | K14T                | 4D56-1 (2,5)  | X        | Enkel    | –                       | –                | Diesel S-RGS      | R5M21-1            | 5M/T         | --                   |
| L200 4WD           | K32T                | 4G63-9 (2,0)  | X        | Enkel    | X                       | –                | CARB              | V5M21-1            | 5M/T         | X                    |

## 1994 modellen voor Europa

| Voertuig-<br>model | Voertuig<br>model-<br>code | Motor            |          |          |                                 |                           | Brand-<br>stof-<br>systeem | Versnellingsbak    |              |                               |
|--------------------|----------------------------|------------------|----------|----------|---------------------------------|---------------------------|----------------------------|--------------------|--------------|-------------------------------|
|                    |                            | Model<br>(liter) | Balansas | Nokkenas | Hydrau-<br>lische<br>klepstoter | Turbo-<br>compres-<br>sor |                            | Model              | Type         | Vierwiel-<br>aandrij-<br>ving |
| L200<br>4WD        | K24T<br>K34T               | 4D56-1<br>(2,5)  | X        | Enkel    | –                               | X                         | Diesel<br>S-RGS            | V5M21-1            | 5M/T         | X                             |
|                    | K34T                       | 4D56-2<br>(2,5)  | X        | Enkel    | –                               | X                         | Diesel<br>S-RGS            | V5M21-1            | 5M/T         | X                             |
|                    | K33T                       | G54B-1<br>(2,6)  | X        | Enkel    | X                               | –                         | ELEC.<br>CARB              | V5M21-1            | 5M/T         | X                             |
| L300               | P02V<br>P12V               | 4G32-8<br>(1,6)  | –        | Enkel    | –                               | –                         | CARB                       | R5M21-2            | 5M/T         | –                             |
|                    | P03V                       | 4G63-9<br>(2,0)  | X        | Enkel    | X                               | –                         | ELEC.<br>CARB              | R5M21-2            | 5M/T         | –                             |
|                    | P03W                       | 4G63-9<br>(2,0)  | X        | Enkel    | X                               | –                         | CARB                       | R5M21-2<br>R4AW2-2 | 5M/T<br>4A/T | –<br>–                        |
|                    |                            |                  |          |          |                                 |                           | ELEC.<br>CARB              | R5M21-2            | 5M/T         | –                             |
|                    | P13V                       | 4G63-9<br>(2,0)  | X        | Enkel    | X                               | –                         | CARB                       | R5M21-2            | 5M/T         | –                             |
|                    |                            |                  |          |          |                                 |                           | ELEC.<br>CARB              | R5M21-2            | 5M/T         | –                             |
|                    | P04V<br>P04W<br>P14V       | 4G64-3<br>(2,4)  | X        | Enkel    | X                               | –                         | MPI                        | R5M21-2            | 5M/T         | –                             |
|                    | P05V<br>P05W<br>P15V       | 4D56-1<br>(2,5)  | X        | Enkel    | –                               | –                         | Diesel<br>S-RGS            | R5M21-2            | 5M/T         | –                             |
|                    | P15V                       | 4D56-2<br>(2,5)  | X        | Enkel    | –                               | –                         | Diesel<br>S-RGS            | R5M21-2            | 5M/T         | –                             |
|                    | L032P                      | 4G32-8<br>(1,6)  | –        | Enkel    | –                               | –                         | CARB                       | R5M21-3            | 5M/T         | –                             |
| L039P              | 4D56-1<br>(2,5)            | X                | Enkel    | –        | –                               | Diesel<br>S-RGS           | R5M21-3                    | 5M/T               | –            |                               |
| L300<br>4WD        | P24V<br>P24W               | 4G64-3<br>(2,4)  | X        | Enkel    | X                               | –                         | MPI                        | V5M21-2            | 5M/T         | X                             |
|                    | P25V<br>P45V<br>P25W       | 4D56-1<br>(2,5)  | X        | Enkel    | –                               | X                         | Diesel<br>S-RGS            | V5M21-2            | 5M/T         | X                             |
|                    |                            | 4D56-2<br>(2,5)  | X        | Enkel    | –                               | X                         | Diesel<br>S-RGS            | V5M21-2            | 5M/T         | X                             |
| 3000GT             | Z16A                       | 6G72-4<br>(3,0)  | –        | Vier     | X                               | X                         | MPI                        | W5MG1-2            | 5M/T         | X                             |
| Eclipse            | D22A                       | 4G63-7<br>(2,0)  | X        | Dubbel   | X                               | –                         | MPI                        | F5M31-2            | 5M/T         | –                             |
|                    | D27A                       | 4G63-7<br>(2,0)  | X        | Dubbel   | X                               | –                         | MPI                        | W5M33-2            | 5M/T         | X                             |

1994 modellen voor algemene export

| Voertuig-model             | Voertuig-model-code | Motor           |          |          |                         |                  | Brandstof-systeem  | Versnellingsbak               |                      |                      |
|----------------------------|---------------------|-----------------|----------|----------|-------------------------|------------------|--------------------|-------------------------------|----------------------|----------------------|
|                            |                     | Model (liter)   | Balansas | Nokkenas | Hydraulische klepstoter | Turbo-compressor |                    | Model                         | Type                 | Vierwiel-aandrijving |
| Lancer/<br>Lancer<br>Wagon | CB1A                | 4G13-2<br>(1,3) | -        | Enkel    | -                       | -                | CARB               | F5M21-1<br>F3A21-2            | 5M/T<br>3A/T         | -<br>-               |
|                            |                     |                 |          |          |                         |                  | ELEC.<br>CARB      | F5M21-1<br>F3A21-2            | 5M/T<br>3A/T         | -<br>-               |
|                            |                     |                 |          |          |                         |                  | MPI                | F5M21-1                       | 5M/T                 | -                    |
|                            | CB2A<br>CB2W        | 4G15-2<br>(1,5) | -        | Enkel    | -                       | -                | CARB               | F5M21-1<br>F3A21-2            | 5M/T<br>3A/T         | -<br>-               |
|                            |                     |                 |          |          |                         |                  | MPI                | F5M22-2<br>F4A21-2<br>F4A22-2 | 5M/T<br>4A/T<br>4A/T | -<br>-<br>-          |
|                            | CB4A                | 4G92-0<br>(1,6) | -        | Enkel    | -                       | -                | MPI                | F5M22-2<br>F4A21-2<br>F4A22-2 | 5M/T<br>4A/T<br>4A/T | -<br>-<br>-          |
|                            | CB8A                | 4D68-0<br>(2,0) | X        | Enkel    | -                       | -                | Diesel<br>S-RGS    | F5M22-1                       | 5M/T                 | -                    |
|                            | CB3A                | 4G91-1<br>(1,5) | -        | Dubbel   | X                       | -                | MPI                | F5M21-1<br>F4A21-2            | 5M/T<br>4A/T         | -<br>-               |
|                            | CB5A                | 4G93-1<br>(1,8) | -        | Dubbel   | X                       | -                | MPI                | F5M22-2                       | 5M/T                 | -                    |
| CB1W                       | 4G13-2<br>(1,3)     | -               | Enkel    | -        | -                       | CARB             | F5M21-1<br>F3A21-2 | 5M/T<br>3A/T                  | -<br>-               |                      |
|                            |                     |                 |          |          |                         | ELEC.<br>CARB    | F5M21-1            | 5M/T                          | -                    |                      |
|                            |                     |                 |          |          |                         | MPI              | F5M22-2            | 5M/T                          | -                    |                      |
| CB4W                       | 4G92-0<br>(1,6)     | -               | Enkel    | -        | -                       | MPI              | F5M22-2            | 5M/T                          | -                    |                      |
| Space<br>Runner            | N11W                | 4G93-0<br>(1,8) | -        | Enkel    | -                       | -                | CARB               | F5M22-1<br>F4A22-2            | 5M/T<br>4A/T         | -<br>-               |
|                            |                     |                 |          |          |                         |                  | MPI                | F5M22-1<br>F4A22-2            | 5M/T<br>4A/T         | -<br>-               |
| Space<br>Wagon             | N31W                | 4G93-0<br>(1,8) | -        | Enkel    | -                       | -                | CARB               | F5M22-1<br>F4A22-2            | 5M/T<br>4A/T         | -<br>-               |
|                            |                     |                 |          |          |                         |                  | MPI                | F5M22-1<br>F4A22-2            | 5M/T<br>4A/T         | -<br>-               |
|                            | N33W                | 4G63-6<br>(2,0) | X        | Enkel    | X                       | -                | MPI                | F5M22-1<br>F4A22-2            | 5M/T<br>4A/T         | -<br>-               |
| Galant                     | E52A                | 4G93-0<br>(1,8) | -        | Enkel    | -                       | -                | CARB               | F5M22-2<br>F4A22-2            | 5M/T<br>4A/T         | -<br>-               |
|                            |                     |                 |          |          |                         |                  | MPI                | F5M22-2<br>F4A22-2            | 5M/T<br>4A/T         | -<br>-               |
|                            | E54A                | 6A12-0<br>(2,0) | -        | Vier     | X                       | -                | MPI                | F5M31-2<br>F4A23-2            | 5M/T<br>4A/T         | -<br>-               |
|                            | E55A                | 4G63-6<br>(2,0) | X        | Enkel    | X                       | -                | CARB               | F5M22-2<br>F4A22-2            | 5M/T<br>4A/T         | -<br>-               |
|                            |                     |                 |          |          |                         |                  | MPI                | F5M22-2<br>F4A22-2            | 5M/T<br>4A/T         | -<br>-               |

## 1994 modellen voor algemene export

| Voertuig-<br>model | Voertuig<br>model-<br>code | Model<br>(liter) | Motor    |          |                                 |                           | Brand-<br>stof-<br>systeem | Versnellingsbak    |              |                               |
|--------------------|----------------------------|------------------|----------|----------|---------------------------------|---------------------------|----------------------------|--------------------|--------------|-------------------------------|
|                    |                            |                  | Balansas | Nokkenas | Hydrau-<br>lische<br>klepstoter | Turbo-<br>compres-<br>sor |                            | Model              | Type         | Vierwiel-<br>aandrij-<br>ving |
| Pajero/<br>Montero | V12C                       | 4G54-1<br>(2,6)  | –        | Enkel    | –                               | –                         | CARB                       | V5M21-5<br>V4AW2-3 | 5M/T<br>4A/T | X<br>X                        |
|                    | V32W                       | 4G54-1<br>(2,6)  | –        | Enkel    | –                               | –                         | CARB                       | V5M21-5            | 5M/T         | X                             |
|                    | V14C<br>V14V               | 4D56-1<br>(2,5)  | X        | Enkel    | –                               | –                         | Diesel<br>S-RGS            | V5M21-6            | 5M/T         | X                             |
|                    | V12V<br>V12W<br>V32V       | 4G54-1<br>(2,6)  | –        | Enkel    | –                               | –                         | CARB                       | V5M21-6            | 5M/T         | X                             |
|                    | V14V<br>V24W               | 4D56-1<br>(2,5)  | X        | Enkel    | –                               | X                         | Diesel<br>S-RGS            | V5M21-6            | 5M/T         | X                             |
|                    | V25W<br>V45W               | 6G74-1<br>(3,5)  | –        | Vier     | X                               | –                         | MPI                        | V5M31-5<br>V4AW3-7 | 5M/T<br>4A/T | X<br>X                        |
|                    | V23W<br>V43W               | 6G72-1<br>(3,0)  | –        | Dubbel   | X                               | –                         | MPI                        | V5MT1-6<br>V4AW2-7 | 5M/T<br>4A/T | X<br>X                        |
|                    | V36V<br>V36W               | 4M40<br>(2,8)    | X        | Enkel    | –                               | –                         | Diesel<br>S-RGS            | V5M21-6            | 5M/T         | X                             |
|                    | V46W                       | 4M40<br>(2,8)    | X        | Enkel    | –                               | X                         | Diesel<br>S-RGS            | V5M31-5<br>V4AW3-7 | 5M/T<br>4A/T | X<br>X                        |
| L200               | K01T<br>K11T               | 4G32-8<br>(1,6)  | –        | Enkel    | –                               | –                         | CARB                       | R4M21-1            | 4M/T         | –                             |
|                    | K02T<br>K12T               | 4G63-8<br>(2,0)  | –        | Enkel    | –                               | –                         | CARB                       | R5M21-1            | 5M/T         | –                             |
|                    | K03T<br>K13T               | 4G54-1<br>(2,6)  | –        | Enkel    | –                               | –                         | CARB                       | R5M21-1            | 5M/T         | –                             |
|                    | K14T                       | 4D56-1<br>(2,5)  | X        | Enkel    | –                               | –                         | Diesel<br>S-RGS            | R5M21-1            | 5M/T         | –                             |
|                    | K15T                       | 4G64-3<br>(2,4)  | X        | Enkel    | X                               | –                         | MPI                        | R5M21-1            | 5M/T         | –                             |
| L200<br>4WD        | K22T<br>K32T               | 4G63-8<br>(2,0)  | –        | Enkel    | –                               | –                         | CARB                       | V5M21-1            | 5M/T         | X                             |
|                    | K24T<br>K34T               | 4D56-1<br>(2,5)  | X        | Enkel    | –                               | –                         | Diesel<br>S-RGS            | V5M21-1            | 5M/T         | X                             |
|                    |                            |                  | X        | Enkel    | –                               | X                         | Diesel<br>S-RGS            | V5M21-1            | 5M/T         | X                             |
|                    | K35T                       | 4G64-3<br>(2,4)  | X        | Enkel    | X                               | –                         | MPI                        | V5M21-1            | 5M/T         | X                             |

## 1994 modellen voor algemene export

| Voertuig-<br>model | Voertuig<br>model-<br>code | Motor            |          |          |                                 |                           | Brand-<br>stof-<br>systeem | Versnellingsbak    |              |                               |
|--------------------|----------------------------|------------------|----------|----------|---------------------------------|---------------------------|----------------------------|--------------------|--------------|-------------------------------|
|                    |                            | Model<br>(liter) | Balansas | Nokkenas | Hydrau-<br>lische<br>klepstoter | Turbo-<br>compres-<br>sor |                            | Model              | Type         | Vierwiel-<br>aandrij-<br>ving |
| L300               | P01V                       | 4G33-8<br>(1,4)  | –        | Enkel    | –                               | –                         | CARB                       | R4M21-2            | 4M/T         | –                             |
|                    |                            | G33B-8<br>(1,4)  | –        | Enkel    | –                               | –                         | CARB                       | R4M21-2            | 4M/T         | –                             |
|                    | P01W                       | 4G33-8<br>(1,4)  | –        | Enkel    | –                               | –                         | CARB                       | R4M21-2            | 4M/T         | –                             |
|                    | P12V<br>P12W               | 4G32-8<br>(1,6)  | –        | Enkel    | –                               | –                         | CARB                       | R4M21-2            | 4M/T         | –                             |
|                    | P03V<br>P13V<br>P13W       | 4G63-8<br>(2,0)  | –        | Enkel    | –                               | –                         | CARB                       | R5M21-2            | 5M/T         | –                             |
|                    | P03W                       | 4G63-8<br>(2,0)  | –        | Enkel    | –                               | –                         | CARB                       | R5M21-2<br>R4AW2-2 | 5M/T<br>4A/T | –<br>–                        |
|                    | P04W                       | 4G64-3<br>(2,4)  | X        | Enkel    | X                               | –                         | MPI                        | R4AW2-2            | 4A/T         | –                             |
|                    | P14V                       | 4G64-3<br>(2,4)  | X        | Enkel    | X                               | –                         | MPI                        | R5M21-2            | 5M/T         | –                             |
|                    | P05V<br>P15V<br>P15W       | 4D56-1<br>(2,5)  | X        | Enkel    | –                               | –                         | Diesel<br>S-RGS            | R5M21-2            | 5M/T         | –                             |
|                    | P05W                       | 4D56-1<br>(2,5)  | X        | Enkel    | –                               | –                         | Diesel<br>S-RGS            | R5M21-2            | 5M/T         | –                             |
| L300<br>4WD        | P23W                       | 4G63-8<br>(2,0)  | –        | Enkel    | –                               | –                         | CARB                       | V5M21-2            | 5M/T         | X                             |
|                    | P24W                       | 4G64-3<br>(2,4)  | X        | Enkel    | X                               | –                         | MPI                        | V5M21-2            | 5M/T         | X                             |
| Sigma              | F16A                       | 6G72-1<br>(3,0)  | –        | Dubbel   | X                               | –                         | MPI                        | F5M33-2<br>F4A33-1 | 5M/T<br>4A/T | –<br>–                        |
|                    |                            | 6G72-4<br>(3,0)  | –        | Vier     | X                               | –                         | MPI                        | F5M33-2<br>F4A33-1 | 5M/T<br>4A/T | –<br>–                        |
| Diamante           | F26A                       | 6G72-4<br>(3,0)  | –        | Vier     | X                               | –                         | MPI                        | W4A33-1            | 4A/T         | X                             |
| 3000GT             | Z16A                       | 6G72-4<br>(3,0)  | –        | Vier     | X                               | X                         | MPI                        | W6MG1-0            | 6M/T         | X                             |

## 1994 modellen voor Australië

| Voertuig-<br>model | Voertuig<br>model-<br>code | Motor            |          |          |                                 |                                | Brand-<br>stof-<br>systeem | Versnellingsbak    |              |                               |
|--------------------|----------------------------|------------------|----------|----------|---------------------------------|--------------------------------|----------------------------|--------------------|--------------|-------------------------------|
|                    |                            | Model<br>(liter) | Balansas | Nokkenas | Hydrau-<br>lische<br>klepstoter | Turbo-<br>com-<br>pres-<br>sor |                            | Model              | Type         | Vierwiel-<br>aandrij-<br>ving |
| Space<br>Wagon     | N34W                       | 4G64-2<br>(2,4)  | X        | Enkel    | X                               | –                              | MPI                        | F5M31-2<br>F4A23-2 | 5M/T<br>4A/T | –<br>–                        |
| Galant             | E54A                       | 6A12-0<br>(2,0)  | –        | Vier     | X                               | –                              | MPI                        | F5M31-2<br>F4A23-2 | 5M/T<br>4A/T | –<br>–                        |
|                    | E55A                       | 4G63-6<br>(2,0)  | X        | Enkel    | X                               | –                              | MPI                        | F5M22-2<br>F4A22-2 | 5M/T<br>4A/T | –<br>–                        |
| Pajero/<br>Montero | V23W<br>V43W               | 6G72-1<br>(3,0)  | –        | Dubbel   | X                               | –                              | MPI                        | V5MT1-6<br>V4AW2-7 | 5M/T<br>4A/T | X<br>X                        |
|                    | V36W                       | 4M40<br>(2,8)    | X        | Enkel    | –                               | –                              | Diesel<br>S-RGS            | V5M21-6            | 5M/T         | X                             |
|                    | V46W                       | 4M40<br>(2,8)    | X        | Enkel    | –                               | X                              | Diesel<br>S-RGS            | V5M31-5            | 5M/T         | X                             |
|                    | V45W                       | 6G74-1<br>(3,5)  | –        | Vier     | X                               | –                              | MPI                        | V4AW3-7            | 4A/T         | X                             |
| L200               | K13T                       | 4G54-1<br>(2,6)  | X        | Enkel    | X                               | –                              | CARB                       | R5M21-1            | 5M/T         | –                             |
|                    | K14T                       | 4D56-1<br>(2,5)  | X        | Enkel    | –                               | –                              | Diesel<br>S-RGS            | R5M21-1            | 5M/T         | –                             |
| L200<br>4WD        | K33T                       | 4G54-1<br>(2,6)  | X        | Enkel    | X                               | –                              | CARB                       | V5M21-1            | 5M/T         | X                             |
|                    | K34T                       | 4D56-1<br>(2,5)  | X        | Enkel    | –                               | X                              | Diesel<br>S-RGS            | V5M21-1            | 5M/T         | X                             |
|                    | K36T                       | 6D72-1<br>(3,0)  | –        | Dubbel   | X                               | –                              | MPI                        | V5MT1-2            | 5M/T         | X                             |
| L300               | P03V<br>P03W               | 4G63-9<br>(2,0)  | X        | Enkel    | X                               | –                              | CARB                       | R5M21-2<br>R4AW2-2 | 5M/T<br>4A/T | –<br>–                        |
|                    | P04W<br>P14V               | 4G64-3<br>(2,4)  | X        | Enkel    | X                               | –                              | MPI                        | R5M21-2<br>R4AW2-2 | 5M/T<br>4A/T | –<br>–                        |
|                    | P05V<br>P15V               | 4D56-1<br>(2,5)  | X        | Enkel    | –                               | –                              | Diesel<br>S-RGS            | R5M21-2<br>R4AW2-2 | 5M/T<br>4A/T | –<br>–                        |
| L300<br>4WD        | P24V<br>P24W               | 4G64-3<br>(2,4)  | X        | Enkel    | X                               | –                              | MPI                        | V5M21-2            | 5M/T         | X                             |
| 3000GT             | Z16A                       | 6G72-4<br>(3,0)  | –        | Vier     | X                               | X                              | MPI                        | W6MG1-0            | 6M/T         | X                             |

1995 modellen voor Europa

| Voertuig-<br>model         | Voertuig<br>model-<br>code | Motor            |          |          |                                 |                          | Brand-<br>stof-<br>systeem | Versnelingsbak     |              |                               |
|----------------------------|----------------------------|------------------|----------|----------|---------------------------------|--------------------------|----------------------------|--------------------|--------------|-------------------------------|
|                            |                            | Model<br>(liter) | Balansas | Nokkenas | Hydrau-<br>lische<br>klepstoter | Turbo<br>compres-<br>sor |                            | Model              | Type         | Vierwiel-<br>aandrij-<br>ving |
| Colt                       | CA1A                       | 4G13-2<br>(1,3)  | -        | Enkel    | -                               | -                        | MPI                        | F5M21-1            | 5M/T         | -                             |
|                            | CA4A                       | 4G92-0<br>(1,6)  | -        | Enkel    | -                               | -                        | MPI                        | F5M22-2<br>F4A22-2 | 5M/T<br>4A/T | -<br>-                        |
|                            | CA5A                       | 4G93-1<br>(1,8)  | -        | Dubbel   | x                               | -                        | MPI                        | F5M22-2            | 5M/T         | -                             |
|                            | CC4A                       | 4G92-0<br>(1,6)  | -        | Enkel    | -                               | -                        | MPI                        | W5M31-2            | 5M/T         | x                             |
| Lancer/<br>Lancer<br>Wagon | CB1A                       | 4G13-2<br>(1,3)  | -        | Enkel    | -                               | -                        | MPI                        | F5M21-1            | 5M/T         | -                             |
|                            | CB4A<br>CB4W               | 4G92-0<br>(1,6)  | -        | Enkel    | -                               | -                        | MPI                        | F5M22-2<br>F4A22-2 | 5M/T<br>4A/T | -<br>-                        |
|                            | CB5A                       | 4G93-1<br>(1,8)  | -        | Dubbel   | x                               | -                        | MPI                        | F5M22-2            | 5M/T         | -                             |
|                            | CB8A<br>CB8W               | 4D68-0<br>(2,0)  | x        | Enkel    | -                               | -                        | Diesel<br>S-RGS            | F5M22-1            | 5M/T         | -                             |
|                            | CD4W                       | 4G92-1<br>(1,6)  | -        | Enkel    | -                               | -                        | MPI                        | W5M31-2            | 5M/T         | x                             |
|                            | C61A                       | 4G13-2<br>(1,3)  | -        | Enkel    | -                               | -                        | MPI                        | F5M21-1            | 5M/T         | -                             |
|                            | C66A                       | 4G92-0<br>(1,6)  | -        | Enkel    | -                               | -                        | MPI                        | F5M22-2<br>F4A21-2 | 5M/T<br>4A/T | -<br>-                        |
|                            | C67A                       | 4D68-0<br>(2,0)  | x        | Enkel    | -                               | -                        | Diesel<br>S-RGS            | F5M22-1            | 5M/T         | -                             |
|                            | C69A                       | 4G93-1<br>(1,8)  | -        | Dubbel   | x                               | -                        | MPI                        | F5M22-2            | 5M/T         | -                             |
| C76A                       | 4G92-0<br>(1,6)            | -                | Enkel    | -        | -                               | MPI                      | W5M31-2                    | 5M/T               | x            |                               |



## 1995 modellen voor Europa

| Voertuig-<br>model | Voertuig-<br>model-<br>code | Motor            |          |          |                                 |                          | Brand-<br>stof-<br>systeem | Versnelingsbak     |              |                               |
|--------------------|-----------------------------|------------------|----------|----------|---------------------------------|--------------------------|----------------------------|--------------------|--------------|-------------------------------|
|                    |                             | Model<br>(liter) | Balansas | Nokkenas | Hydrau-<br>lische<br>klepstoter | Turbo<br>compres-<br>sor |                            | Model              | Type         | Vierwiel-<br>aandrij-<br>ving |
| Space<br>Runner    | N11W                        | 4G93-0<br>(1,8)  | –        | Enkel    | –                               | –                        | MPI                        | F5M22-1<br>F4A22-2 | 5M/T<br>4A/T | –<br>–                        |
|                    | N18W                        | 4D68-0<br>(2,0)  | ×        | Enkel    | –                               | ×                        | Diesel<br>S-RGS            | F5M31-1            | 5M/T         | –                             |
|                    | N21W                        | 4G93-0<br>(1,8)  | –        | Enkel    | –                               | –                        | MPI                        | W5M31-2            | 5M/T         | ×                             |
| Space<br>Wagon     | N33W                        | 4G63-6<br>(2,0)  | ×        | Enkel    | ×                               | –                        | MPI                        | F5M22-1<br>F4A22-2 | 5M/T<br>4A/T | –<br>–                        |
|                    | N34W                        | 4G64-2<br>(2,4)  | ×        | Enkel    | ×                               | –                        | MPI                        | F5M22-1<br>F4A32-2 | 5M/T<br>4A/T | –<br>–                        |
|                    | N38W                        | 4D68-0<br>(2,0)  | ×        | Enkel    | –                               | ×                        | Diesel<br>S-RGS            | F5M31-1            | 5M/T         | –                             |
|                    | N43W                        | 4G63-6<br>(2,0)  | ×        | Enkel    | ×                               | –                        | MPI                        | W5M31-2<br>W4A32-1 | 5M/T<br>4A/T | ×<br>×                        |
| Galant             | E52A                        | 4G93-0<br>(1,8)  | –        | Enkel    | –                               | –                        | MPI                        | F5M22-2<br>F4A22-2 | 5M/T<br>4A/T | –<br>–                        |
|                    | E54A                        | 6A12-0<br>(2,0)  | –        | Vier     | ×                               | –                        | MPI                        | F5M31-2<br>F4A23-2 | 5M/T<br>4A/T | –<br>–                        |
|                    | E55A                        | 4G63-6<br>(2,0)  | ×        | Enkel    | ×                               | –                        | MPI                        | F5M22-2<br>F4A22-2 | 5M/T<br>4A/T | –<br>–                        |
|                    | E57A                        | 4D68-0<br>(2,0)  | ×        | Enkel    | –                               | ×                        | Diesel<br>S-RGS            | F5M31-1            | 5M/T         | –                             |
|                    | E75A                        | 4G63-6<br>(2,0)  | ×        | Enkel    | ×                               | –                        | MPI                        | W5M31-2            | 5M/T         | ×                             |
|                    | E88A                        | 6G73-1<br>(2,5)  | –        | Vier     | ×                               | –                        | MPI                        | W5M33-2            | 5M/T         | ×                             |
| Sigma              | F16A                        | 6G72-1<br>(3,0)  | –        | Dubbel   | ×                               | –                        | MPI                        | F5M33-2<br>F4A33-1 | 5M/T<br>4A/T | –<br>–                        |
|                    | F16A                        | 6G72-4<br>(3,0)  | –        | Vier     | ×                               | –                        | MPI                        | F5M33-2<br>F4A33-1 | 5M/T<br>4A/T | –<br>–                        |

## 1995 modellen voor Europa

| Voertuig-<br>model | Voertuig<br>model-<br>code | Motor            |          |          |                                 |                          | Brand-<br>stof-<br>systeem | Versnelingsbak     |              |                               |   |
|--------------------|----------------------------|------------------|----------|----------|---------------------------------|--------------------------|----------------------------|--------------------|--------------|-------------------------------|---|
|                    |                            | Model<br>(liter) | Balansas | Nokkenas | Hydrau-<br>lische<br>klepstoter | Turbo<br>compres-<br>sor |                            | Model              | Type         | Vierwiel-<br>aandrij-<br>ving |   |
| Pajero/<br>Montero | V23C<br>V23W<br>V43W       | 6G72-1<br>(3,0)  | –        | Dubbel   | ×                               | –                        | MPI                        | V5MT1-6<br>V4AW2-7 | 5M/T<br>4A/T | ×                             | × |
|                    | V24C<br>V24W<br>V44W       | 4D56-2<br>(2,5)  | ×        | Enkel    | –                               | ×                        | Diesel<br>S-RGS            | V5MT1-5            | 5M/T         | ×                             | × |
|                    | V25W<br>V45W               | 6G74-1<br>(3,5)  | –        | Vier     | ×                               | –                        | MPI                        | V5M31-5<br>V4AW3-7 | 5M/T<br>4A/T | ×                             | × |
|                    | V46W                       | 4M40<br>(2,8)    | ×        | Enkel    | –                               | ×                        | Diesel<br>S-RGS            | V5M31-5<br>V4AW3-7 | 5M/T<br>4A/T | ×                             | × |
| L200               | K12T                       | 4G63-9<br>(2,0)  | ×        | Enkel    | ×                               | –                        | CARB                       | R5M21-1            | 5M/T         | –                             | – |
|                    | K14T                       | 4D56-2<br>(2,5)  | ×        | Enkel    | –                               | –                        | Diesel<br>S-RGS            | R5M21-1            | 5M/T         | –                             | – |
|                    | K15T                       | 4G64-3<br>(2,4)  | ×        | Enkel    | ×                               | –                        | MPI                        | R5M21-1            | 5M/T         | –                             | – |
| L200<br>4WD        | K24T<br>K34T               | 4D56-2<br>(2,5)  | ×        | Enkel    | –                               | –                        | Diesel<br>S-RGS            | V5M21-1            | 5M/T         | ×                             | × |
|                    | K35T                       | 4G64-3<br>(2,4)  | ×        | Enkel    | ×                               | –                        | MPI                        | V5M21-1            | 5M/T         | ×                             | × |
|                    | K33T                       | 4G54-1<br>(2,6)  | ×        | Enkel    | ×                               | –                        | ELEC<br>CARB               | V5M21-1            | 5M/T         | ×                             | × |
| L300               | P03V<br>P13V               | 4G63-9<br>(2,0)  | ×        | Enkel    | ×                               | –                        | ELEC<br>CARB               | R5M21-2            | 5M/T         | –                             | – |
|                    | P05V<br>P15V               | 4D56-2<br>(2,5)  | ×        | Enkel    | –                               | –                        | Diesel<br>S-RGS            | R5M21-1            | 5M/T         | –                             | – |
| L300<br>4WD        | P25T<br>P45T               | 4D56-2<br>(2,5)  | ×        | Enkel    | –                               | ×                        | Diesel<br>S-RGS            | V5M21-1            | 5M/T         | ×                             | × |

## 1995 modellen voor Europa

| Voertuig-<br>model | Voertuig<br>model-<br>code | Motor            |          |          |                                 |                          | Brand-<br>stof-<br>systeem | Versnelingsbak     |              |                               |
|--------------------|----------------------------|------------------|----------|----------|---------------------------------|--------------------------|----------------------------|--------------------|--------------|-------------------------------|
|                    |                            | Model<br>(liter) | Balansas | Nokkenas | Hydrau-<br>lische<br>klepstoter | Turbo<br>compres-<br>sor |                            | Model              | Type         | Vierwiel-<br>aandrij-<br>ving |
| L400               | PA3V<br>PB3V               | 4G63-A<br>(2,0)  | ×        | Enkel    | ×                               | –                        | ELEC<br>CARB               | R5M21-7            | 5M/T         | –                             |
|                    | PA3V<br>PB3V               | 4G63-6<br>(2,0)  | ×        | Enkel    | ×                               | –                        | MPI                        | R5M21-7            | 5M/T         | –                             |
|                    | PA5V<br>PB5V               | 4D56-2<br>(2,5)  | ×        | Enkel    | –                               | ×                        | Diesel<br>S-RGS            | R5M21-1            | 5M/T         | –                             |
|                    | PD4V                       | 4G64-2<br>(2,4)  | ×        | Enkel    | ×                               | –                        | MPI                        | V5M21-7            | 5M/T         | ×                             |
|                    | PD5V                       | 4D56-2<br>(2,5)  | ×        | Enkel    | –                               | ×                        | Diesel<br>S-RGS            | V5M21-7            | 5M/T         | ×                             |
|                    | PA3W                       | 4G63-6<br>(2,0)  | ×        | Enkel    | ×                               | –                        | MPI                        | R5M21-7<br>R4AW2-5 | 5M/T<br>4A/T | –<br>–                        |
|                    | PA4W                       | 4G64-2<br>(2,4)  | ×        | Enkel    | ×                               | –                        | MPI                        | R5M21-7<br>R4AW2-5 | 5M/T<br>4A/T | –<br>–                        |
|                    | PA5W                       | 4D56-2<br>(2,5)  | ×        | Enkel    | –                               | ×                        | Diesel<br>S-RGS            | R5M31-7            | 5M/T         | –                             |
|                    | PD4W                       | 4G64-2<br>(2,4)  | ×        | Enkel    | ×                               | –                        | MPI                        | V5M21-7            | 5M/T         | ×                             |
|                    | PD5W                       | 4D56-2<br>(2,5)  | ×        | Enkel    | –                               | ×                        | Diesel<br>S-RGS            | V5M31-7            | 5M/T         | ×                             |
| 3000GT             | Z16A                       | 6G72-4<br>(3,0)  | –        | Vier     | ×                               | ×                        | MPI                        | W5MG1-2            | 5M/T         | ×                             |
| Eclipse            | D22A                       | 4G63-7<br>(2,0)  | ×        | Dubbel   | ×                               | –                        | MPI                        | F5M31-2            | 5M/T         | –                             |
|                    | D27A                       | 4G63-7<br>(2,0)  | ×        | Dubbel   | ×                               | –                        | MPI                        | W5M33-2            | 5M/T         | ×                             |

## 1995 modellen voor algemene export

| Voertuig-<br>model         | Voertuig<br>model-<br>code | Motor            |          |          |                                 |                          | Brand-<br>stof-<br>systeem | Versnelingsbak     |              |                               |
|----------------------------|----------------------------|------------------|----------|----------|---------------------------------|--------------------------|----------------------------|--------------------|--------------|-------------------------------|
|                            |                            | Model<br>(liter) | Balansas | Nokkenas | Hydrau-<br>lische<br>klepstoter | Turbo<br>compres-<br>sor |                            | Model              | Type         | Vierwiel-<br>aandrij-<br>ving |
| Colt                       | CA1A                       | 4G13-2<br>(1,3)  | -        | Enkel    | -                               | -                        | CARB                       | F5M21-1            | 5M/T         | -                             |
|                            | CA2A                       | 4G15-2<br>(1,5)  | -        | Enkel    | -                               | -                        | CARB                       | F5M21-1<br>F3A21-2 | 5M/T<br>3A/T | -<br>-                        |
|                            | CA4A                       | 4G92-0<br>(1,6)  | -        | Enkel    | -                               | -                        | MPI                        | F5M22-2<br>F4A22-2 | 5M/T<br>4A/T | -<br>-                        |
|                            | CA5A                       | 4G93-0<br>(1,8)  | -        | Enkel    | -                               | -                        | MPI                        | F5M22-2<br>F4A22-2 | 5M/T<br>4A/T | -<br>-                        |
|                            | CA5A                       | 4G93-1<br>(1,8)  | -        | Dubbel   | x                               | -                        | MPI                        | F5M22-2            | 5M/T         | -                             |
| Lancer/<br>Lancer<br>Wagon | CB1A                       | 4G13-2<br>(1,3)  | -        | Enkel    | -                               | -                        | CARB                       | F5M21-1            | 5M/T         | -                             |
|                            | CB2A<br>CB2W               | 4G15-2<br>(1,5)  | -        | Enkel    | -                               | -                        | CARB                       | F5M21-1<br>F3A21-2 | 5M/T<br>3A/T | -<br>-                        |
|                            | CB4A<br>CB4W               | 4G92-0<br>(1,6)  | -        | Enkel    | -                               | -                        | MPI                        | F5M22-2<br>F4A22-2 | 5M/T<br>4A/T | -<br>-                        |
|                            | CB5A                       | 4G93-1<br>(1,8)  | -        | Dubbel   | x                               | -                        | MPI                        | F5M22-2            | 5M/T         | -                             |
|                            | CB8A<br>CB8W               | 4D68-0<br>(2,0)  | x        | Enkel    | -                               | -                        | Diesel<br>S-RGS            | F5M22-1            | 5M/T         | -                             |
|                            | C62A                       | 4G15-2<br>(1,5)  | -        | Enkel    | -                               | -                        | CARB                       | F5M21-1            | 5M/T         | -                             |
|                            | C66A                       | 4G92-0<br>(1,6)  | -        | Enkel    | -                               | -                        | MPI                        | F5M22-2<br>F4A21-2 | 5M/T<br>4A/T | -<br>-                        |
| Space<br>Runner            | N11W                       | 4G93-0<br>(1,8)  | -        | Enkel    | -                               | -                        | MPI                        | F5M22-1<br>F4A22-2 | 5M/T<br>4A/T | -<br>-                        |
| Space<br>Wagon             | N31W                       | 4G93-0<br>(1,8)  | -        | Enkel    | -                               | -                        | MPI                        | F5M22-1<br>F4A22-2 | 5M/T<br>4A/T | -<br>-                        |
|                            | N33W                       | 4G63-6<br>(2,0)  | x        | Enkel    | x                               | -                        | MPI                        | F5M22-1<br>F4A22-2 | 5M/T<br>4A/T | -<br>-                        |

## 1995 modellen voor algemene export

| Voertuig-<br>model | Voertuig<br>model-<br>code           | Motor            |          |          |                                 |                          | Brand-<br>stof-<br>systeem | Versnelingsbak     |              |                               |
|--------------------|--------------------------------------|------------------|----------|----------|---------------------------------|--------------------------|----------------------------|--------------------|--------------|-------------------------------|
|                    |                                      | Model<br>(liter) | Balansas | Nokkenas | Hydrau-<br>lische<br>klepstoter | Turbo<br>compres-<br>sor |                            | Model              | Type         | Vierwiel-<br>aandrij-<br>ving |
| Galant             | E52A                                 | 4G93-0<br>(1,8)  | -        | Enkel    | -                               | -                        | MPI<br>CARB                | F5M22-2<br>F4A22-2 | 5M/T<br>4A/T | -<br>-                        |
|                    | E54A                                 | 6A12-0<br>(2,0)  | -        | Vier     | x                               | -                        | MPI                        | F5M31-2<br>F4A23-2 | 5M/T<br>4A/T | -<br>-                        |
|                    | E55A                                 | 4G63-6<br>(2,0)  | x        | Enkel    | x                               | -                        | MPI<br>CARB                | F5M22-2<br>F4A22-2 | 5M/T<br>4A/T | -<br>-                        |
| Sigma              | F16A                                 | 6G72-1<br>(3,0)  | -        | Dubbel   | x                               | -                        | MPI                        | F5M33-2<br>F4A33-1 | 5M/T<br>4A/T | -<br>-                        |
|                    | F16A                                 | 6G72-4<br>(3,0)  | -        | Vier     | x                               | -                        | MPI                        | F5M33-2<br>F4A33-1 | 5M/T<br>4A/T | -<br>-                        |
| Pajero/<br>Montero | V12V<br>V12W<br>V32V<br>V32W         | 4G54-1<br>(2,6)  | -        | Enkel    | -                               | -                        | CARB                       | V5M21-1            | 5M/T         | x                             |
|                    | V13V<br>V23W<br>V33V<br>V33W<br>V43W | 6G72-1<br>(3,0)  | -        | Dubbel   | x                               | -                        | MPI                        | V5MT1-6<br>V4AW2-7 | 5M/T<br>4A/T | x<br>x                        |
|                    | V14C<br>V14V<br>V24W<br>V34V<br>V44W | 4D56-2<br>(2,5)  | x        | Enkel    | -                               | x                        | Diesel<br>S-RGS            | V5MT1-5            | 5M/T         | x                             |
|                    | V25W<br>V45W                         | 6G74-1<br>(3,5)  | -        | Vier     | x                               | -                        | MPI                        | V5M31-5<br>V4AW3-7 | 5M/T<br>4A/T | x<br>x                        |
|                    | V46W                                 | 4M40<br>(2,8)    | x        | Enkel    | -                               | x                        | Diesel<br>S-RGS            | V5M31-5<br>V4AW3-7 | 5M/T<br>4A/T | x<br>x                        |

## 1995 modellen voor algemene export

| Voertuig-<br>model | Voertuig<br>model-<br>code | Motor            |          |          |                                 |                          | Brand-<br>stof-<br>systeem | Versnelingsbak |      |                               |
|--------------------|----------------------------|------------------|----------|----------|---------------------------------|--------------------------|----------------------------|----------------|------|-------------------------------|
|                    |                            | Model<br>(liter) | Balansas | Nokkenas | Hydrau-<br>lische<br>klepstoter | Turbo<br>compres-<br>sor |                            | Model          | Type | Vierwiel-<br>aandrij-<br>ving |
| L200               | K01T<br>K11T               | 4G32-8<br>(1,6)  | -        | Enkel    | -                               | -                        | CARB                       | R4M21-1        | 4M/T | -                             |
|                    | K02T<br>K12T               | 4G63-9<br>(2,0)  | x        | Enkel    | x                               | -                        | CARB                       | R5M21-1        | 5M/T | -                             |
|                    | K03T<br>K13T               | 4G54-1<br>(2,6)  | x        | Enkel    | x                               | -                        | CARB                       | R5M21-1        | 5M/T | -                             |
|                    | K14T                       | 4D56-2<br>(2,5)  | x        | Enkel    | -                               | -                        | Diesel<br>S-RGS            | R5M21-1        | 5M/T | -                             |
|                    | K15T                       | 4G64-3<br>(2,4)  | x        | Enkel    | x                               | -                        | MPI                        | R5M21-1        | 5M/T | -                             |
| L200<br>4WD        | K22T<br>K32T               | 4G63-9<br>(2,0)  | x        | Enkel    | x                               | -                        | CARB                       | V5M21-1        | 5M/T | x                             |
|                    | K24T<br>K34T               | 4D56-1<br>(2,5)  | x        | Enkel    | -                               | -                        | Diesel<br>S-RGS            | V5M21-1        | 5M/T | x                             |
|                    | K35T                       | 4G64-3<br>(2,4)  | x        | Enkel    | x                               | -                        | MPI                        | V5M21-1        | 5M/T | x                             |
| L300               | P03V<br>P13V<br>P13W       | 4G63-9<br>(2,0)  | x        | Enkel    | x                               | -                        | CARB                       | R5M21-2        | 5M/T | -                             |
|                    | P15V<br>P15W               | 4D56-2<br>(2,5)  | x        | Enkel    | -                               | -                        | Diesel<br>S-RGS            | R5M21-1        | 5M/T | -                             |
| L300<br>4WD        | P23W                       | 4G63-9<br>(2,0)  | x        | Enkel    | x                               | -                        | CARB                       | V5M21-2        | 5M/T | x                             |

## 1995 modellen voor algemene export

| Voertuig-<br>model | Voertuig<br>model-<br>code | Motor            |          |          |                                 |                          | Brand-<br>stof-<br>systeem | Versnelingsbak     |              |                               |
|--------------------|----------------------------|------------------|----------|----------|---------------------------------|--------------------------|----------------------------|--------------------|--------------|-------------------------------|
|                    |                            | Model<br>(liter) | Balansas | Nokkenas | Hydrau-<br>lische<br>klepstoter | Turbo<br>compres-<br>sor |                            | Model              | Type         | Vierwiel-<br>aandrij-<br>ving |
| L400               | PA3V<br>PB3V               | 4G63-B<br>(2,0)  | ×        | Enkel    | ×                               | –                        | CARB<br>ELECCARB           | R5M21-7            | 5M/T         | –                             |
|                    | PB4V                       | 4G64-2<br>(2,4)  | ×        | Enkel    | ×                               | –                        | MPI                        | R5M21-7            | 5M/T         | –                             |
|                    | PB5V                       | 4D56-2<br>(2,5)  | ×        | Enkel    | –                               | ×                        | Diesel<br>S-RGS            | R5M21-1            | 5M/T         | –                             |
|                    | PA3W<br>PC3W               | 4G63-6<br>(2,0)  | ×        | Enkel    | ×                               | –                        | CARB                       | R5M21-7<br>R4AW2-5 | 5M/T<br>4A/T | –<br>–                        |
|                    | PA4W                       | 4G64-2<br>(2,4)  | ×        | Enkel    | ×                               | –                        | MPI                        | R4AW2-5            | 4M/T         | –                             |
|                    | PA5W<br>PC5W               | 4D56-2<br>(2,5)  | ×        | Enkel    | –                               | ×                        | Diesel<br>S-RGS            | R5M31-7            | 5M/T         | –                             |
|                    | PD3W                       | 4G63-B<br>(2,0)  | ×        | Enkel    | ×                               | –                        | CARB                       | V5M21-7            | 5M/T         | ×                             |
|                    | PD4W                       | 4G64-2<br>(2,4)  | ×        | Enkel    | ×                               | –                        | MPI                        | V5M21-7            | 5M/T         | ×                             |
| 3000GT             | Z16A                       | 6G72-4<br>(3,0)  | –        | Vier     | ×                               | ×                        | MPI                        | W5MG1-2            | 5M/T         | ×                             |

## 1995 modellen voor Australië

| Voertuig-<br>model         | Voertuig<br>model-<br>code | Motor            |          |          |                                 |                          | Brand-<br>stof-<br>systeem | Versnellingsbak    |              |                               |
|----------------------------|----------------------------|------------------|----------|----------|---------------------------------|--------------------------|----------------------------|--------------------|--------------|-------------------------------|
|                            |                            | Model<br>(liter) | Balansas | Nokkenas | Hydrau-<br>lische<br>klepstoter | Turbo<br>compres-<br>sor |                            | Model              | Type         | Vierwiel-<br>aandrij-<br>ving |
| Lancer/<br>Lancer<br>Wagon | CA2A<br>CB2A               | 4G15-2<br>(1,5)  | -        | Enkel    | -                               | -                        | CARB                       | F5M21-1<br>F3A21-2 | 5M/T<br>3A/T | -<br>-                        |
|                            | CB5W<br>CA5A<br>CB5A       | 4G93-0<br>(1,8)  | -        | Enkel    | x                               | -                        | MPI                        | F5M22-2<br>F4A22-2 | 5M/T<br>4A/T | -<br>-                        |
|                            | CD5A                       | 4G93-1<br>(1,8)  | -        | Dubbel   | x                               | x                        | MPI                        | W5M33-2            | 5M/T         | x                             |
|                            | C62A                       | 4G15-2<br>(1,5)  | -        | Enkel    | -                               | -                        | CARB                       | F5M21-1            | 5M/T         | -                             |
|                            | C66A                       | 4G92-0<br>(1,6)  | -        | Enkel    | -                               | -                        | MPI                        | F5M22-2<br>F4A21-2 | 5M/T         | -                             |
| Space<br>Wagon             | N34W                       | 4G64-2<br>(2,4)  | x        | Enkel    | x                               | -                        | MPI                        | F5M31-2<br>F4A23-2 | 5M/T<br>4A/T | -<br>-                        |
| Galant                     | E54A                       | 6A12-0<br>(2,0)  | -        | Vier     | x                               | -                        | MPI                        | F5M31-2<br>F4A23-2 | 5M/T<br>4A/T | -<br>-                        |
|                            | E55A                       | 4G63-6<br>(2,0)  | x        | Enkel    | x                               | -                        | MPI                        | F5M22-2<br>F4A22-2 | 5M/T<br>4A/T | -<br>-                        |
| Pajero/<br>Montero         | V23W<br>V43W               | 6G72-1<br>(3,0)  | -        | Dubbel   | x                               | -                        | MPI                        | V5MT1-6<br>V4AW2-7 | 5M/T<br>4A/T | x<br>x                        |
|                            | V45W                       | 6G74-1<br>(3,5)  | -        | Vier     | x                               | -                        | MPI                        | V4AW3-7            | 4A/T         | x                             |
|                            | V36W<br>V46W               | 4M40<br>(2,8)    | x        | Enkel    | -                               | x                        | Diesel<br>S-RGS            | V5M31-6            | 5M/T         | x                             |



## 1995 modellen voor Australië

| Voertuig-<br>model | Voertuig-<br>model-<br>code | Motor            |          |          |                                 |                          | Brand-<br>stof-<br>systeem | Versnelingsbak     |              |                               |
|--------------------|-----------------------------|------------------|----------|----------|---------------------------------|--------------------------|----------------------------|--------------------|--------------|-------------------------------|
|                    |                             | Model<br>(liter) | Balansas | Nokkenas | Hydrau-<br>lische<br>klepstoter | Turbo<br>compres-<br>sor |                            | Model              | Type         | Vierwiel-<br>aandrij-<br>ving |
| L200               | K13T                        | 4G54-1<br>(2,6)  | ×        | Enkel    | ×                               | –                        | CARB                       | R5M21-1            | 5M/T         | –                             |
|                    | K14T                        | 4D56-2<br>(2,5)  | ×        | Enkel    | –                               | –                        | Diesel<br>S-RGS            | R5M21-1            | 5M/T         | –                             |
| L200<br>4WD        | K33T                        | 4G54-1<br>(2,6)  | ×        | Enkel    | ×                               | –                        | CARB                       | V5M21-1            | 5M/T         | ×                             |
|                    | K34T                        | 4D56-1<br>(2,5)  | ×        | Enkel    | –                               | –                        | Diesel<br>S-RGS            | V5M21-1            | 5M/T         | ×                             |
|                    | K35T                        | 4G64-3<br>(2,4)  | ×        | Enkel    | ×                               | –                        | MPI                        | V5M21-1            | 5M/T         | ×                             |
| L300               | P03V                        | 4G63-A<br>(2,0)  | ×        | Enkel    | ×                               | –                        | CARB                       | R5M21-2<br>R4AW2-8 | 5M/T<br>4A/T | –<br>–                        |
|                    | P14V                        | 4G64-2<br>(2,4)  | ×        | Enkel    | ×                               | –                        | MPI                        | R5M21-2<br>R4AW2-8 | 5M/T<br>4A/T | –<br>–                        |
|                    | P05V<br>P15V                | 4D56-1<br>(2,5)  | ×        | Enkel    | –                               | –                        | Diesel<br>S-RGS            | R5M21-1<br>R4AW2-8 | 5M/T<br>4A/T | –<br>–                        |
| L300<br>4WD        | P24V                        | 4G64-2<br>(2,4)  | ×        | Enkel    | ×                               | –                        | MPI                        | V5M21-2<br>V4AW2-5 | 5M/T<br>4A/T | ×                             |
| L400               | PA3W                        | 4G63-B<br>(2,0)  | ×        | Enkel    | ×                               | –                        | CARB                       | R5M21-7<br>R4AW2-8 | 5M/T<br>4A/T | –<br>–                        |
|                    | PB4V<br>PB4W                | 4G64-2<br>(2,4)  | ×        | Enkel    | ×                               | –                        | MPI                        | R5M21-7<br>R4AW2-8 | 5M/T<br>4A/T | –<br>–                        |
|                    | PB6W                        | 6G72-8<br>(3,0)  | –        | Dubbel   | ×                               | –                        | MPI                        | R4AW3-5            | 4A/T         | –                             |
| 3000GT             | Z16A                        | 6G72-4<br>(3,0)  | –        | Vier     | ×                               | ×                        | MPI                        | W5MG1-2            | 5M/T         | ×                             |

## 1996 modellen voor Europa

| Voertuig-<br>model | Voertuig<br>model-<br>code | Motor            |          |          |                                 |                          | Brand-<br>stof-<br>systeem | Versnelingsbak     |              |                               |
|--------------------|----------------------------|------------------|----------|----------|---------------------------------|--------------------------|----------------------------|--------------------|--------------|-------------------------------|
|                    |                            | Model<br>(liter) | Balansas | Nokkenas | Hydrau-<br>lische<br>klepstoter | Turbo<br>compres-<br>sor |                            | Model              | Type         | Vierwiel-<br>aandrij-<br>ving |
| Colt               | CJ1A                       | 4G13-3<br>(1,3)  | –        | Enkel    | –                               | –                        | MPI                        | F5M41-1<br>F4A41-1 | 5M/T<br>4A/T | –<br>–                        |
|                    |                            | 4G92-3<br>(1,6)  | –        | Enkel    | –                               | –                        | MPI                        | F5M41-1<br>F4A41-1 | 5M/T<br>4A/T | –<br>–                        |
|                    | 4G92-8<br>(1,6)            | –                | Enkel    | –        | –                               | MPI                      | F5M41-1                    | 5M/T               | –            |                               |
| Lancer             | CB4W                       | 4G92-0<br>(1,6)  | –        | Enkel    | –                               | –                        | MPI                        | F5M22-2<br>F4A22-2 | 5M/T<br>4M/T | –<br>–                        |
|                    | CD4W                       | 4G92-0<br>(1,6)  | –        | Enkel    | –                               | –                        | MPI                        | F5M31-2            | 4M/T         | ×                             |
|                    | CK1A                       | 4G13-3<br>(1,3)  | –        | Enkel    | –                               | –                        | MPI                        | F5M41-1<br>F4A41-1 | 5M/T<br>4A/T | –<br>–                        |
|                    | CK4A                       | 4G92-3<br>(1,6)  | –        | Enkel    | –                               | –                        | MPI                        | F5M41-1<br>F4A41-1 | 5M/T<br>4A/T | –<br>–                        |
| Carisma            | DA1A                       | 4G92-2<br>(1,6)  | –        | Enkel    | –                               | –                        | MPI                        | F5MR1<br>F4A41-1   | 5M/T<br>4A/T | –<br>–                        |
|                    | DA2A                       | 4G93-2<br>(1,8)  | –        | Enkel    | –                               | –                        | MPI                        | F5MR1<br>F4A42-1   | 5M/T<br>4A/T | –<br>–                        |
|                    |                            | 4G93-4<br>(1,8)  | –        | Dubbel   | ×                               | –                        | MPI                        | F5MR1              | 5M/T         | –                             |
| Space<br>Runner    | N11W                       | 4G93-0<br>(1,8)  | –        | Enkel    | –                               | –                        | MPI                        | F5M22-1<br>F4A22-2 | 5M/T<br>4A/T | –<br>–                        |
|                    | N18W                       | 4D68-0<br>(2,0)  | ×        | Enkel    | –                               | ×                        | Diesel<br>S-RGS            | F5M31-1            | 5M/T         | –                             |
|                    | N21W                       | 4G93-0<br>(1,8)  | –        | Enkel    | –                               | –                        | MPI                        | W5M31-2            | 5M/T         | ×                             |
| Space<br>Wagon     | N33W                       | 4G63-6<br>(2,0)  | ×        | Enkel    | ×                               | –                        | MPI                        | F5M22-1<br>F4A22-2 | 5M/T<br>4A/T | –<br>–                        |
|                    |                            | 4G64-2<br>(2,4)  | ×        | Enkel    | ×                               | –                        | MPI                        | F5M22-1<br>F4A23-2 | 5M/T<br>4A/T | –<br>–                        |
|                    | N38W                       | 4D68-0<br>(2,0)  | ×        | Enkel    | –                               | ×                        | Diesel<br>S-RGS            | F5M31-1            | 5M/T         | –                             |

## 1996 modellen voor Europa

| Voertuig-<br>model | Voertuig-<br>model-<br>code | Motor            |          |          |                                 |                          | Brand-<br>stof-<br>systeem | Versnelingsbak     |              |                               |
|--------------------|-----------------------------|------------------|----------|----------|---------------------------------|--------------------------|----------------------------|--------------------|--------------|-------------------------------|
|                    |                             | Model<br>(liter) | Balansas | Nokkenas | Hydrau-<br>lische<br>klepstoter | Turbo<br>compres-<br>sor |                            | Model              | Type         | Vierwiel-<br>aandrij-<br>ving |
| Space<br>Wagon     | N43W                        | 4G63-6<br>(2,0)  | x        | Enkel    | x                               | -                        | MPI                        | W5M31-2            | 5M/T         | x                             |
|                    |                             |                  |          |          |                                 |                          |                            | W4A32-1            | 4A/T         | x                             |
| Galant             | E52A                        | 4G93-0<br>(1,8)  | -        | Enkel    | -                               | -                        | MPI                        | F5M22-2<br>F4A22-2 | 5M/T<br>4A/T | -<br>-                        |
|                    | E54A                        | 6A12-0<br>(2,0)  | -        | Vier     | x                               | -                        | MPI                        | F5M31-2<br>F4A23-2 | 5M/T<br>4A/T | -<br>-                        |
|                    | E55A                        | 4G63-6<br>(2,0)  | x        | Enkel    | x                               | -                        | MPI                        | F5M22-2<br>F4A22-2 | 5M/T<br>4A/T | -<br>-                        |
|                    | E57A                        | 4D68-0<br>(2,0)  | x        | Enkel    | -                               | x                        | Diesel<br>S-RGS            | F5M31-2            | 5M/T         | -                             |
|                    | E75A                        | 4G63-6<br>(2,0)  | x        | Enkel    | x                               | -                        | MPI                        | W5M31-2            | 5M/T         | x                             |
|                    | E88A                        | 6G73-1<br>(2,5)  | -        | Vier     | x                               | -                        | MPI                        | W5M33-2            | 5M/T         | x                             |
| Pajero/<br>Montero | V23C<br>V23W<br>V43W        | 6G72-8<br>(3,0)  | -        | Dubbel   | x                               | -                        | MPI                        | V5MT1-6<br>V4AW3-7 | 5M/T<br>4A/T | x<br>x                        |
|                    | V24C<br>V24W<br>V44W        | 4D56-2<br>(2,5)  | x        | Enkel    | -                               | x                        | Diesel<br>S-RGS            | V5MT1-6            | 5M/T         | x                             |
|                    | V25W<br>V45W                | 6G74-1<br>(3,5)  | -        | Vier     | x                               | -                        | MPI                        | V5M31-5<br>V4AW3-7 | 5M/T<br>4A/T | x<br>x                        |
|                    | V26W<br>V46W                | 4M40<br>(2,8)    | x        | Enkel    | -                               | x                        | Diesel<br>S-RGS            | V5M31-5<br>V4AW3-7 | 5M/T<br>4A/T | x<br>x                        |
| L200               | K14T                        | 4D56-2<br>(2,5)  | x        | Enkel    | -                               | -                        | Diesel<br>S-RGS            | R5M21-1            | 5M/T         | -                             |
|                    | K15T                        | 4G64-3<br>(2,4)  | x        | Enkel    | x                               | -                        | MPI                        | R5M21-1            | 5M/T         | -                             |
| L200<br>4WD        | K24T<br>K34T                | 4D56-2<br>(2,5)  | x        | Enkel    | -                               | x                        | Diesel<br>S-RGS            | V5M21-1            | 5M/T         | x                             |
|                    | K35T                        | 4G64-3<br>(2,4)  | x        | Enkel    | x                               | -                        | MPI                        | V5M21-1            | 5M/T         | x                             |

## 1996 modellen voor Europa

| Voertuig-<br>model | Voertuig<br>model-<br>code | Motor            |          |          |                                 |                          | Brand-<br>stof-<br>systeem | Versnelingsbak     |              |                               |
|--------------------|----------------------------|------------------|----------|----------|---------------------------------|--------------------------|----------------------------|--------------------|--------------|-------------------------------|
|                    |                            | Model<br>(liter) | Balansas | Nokkenas | Hydrau-<br>lische<br>klepstoter | Turbo<br>compres-<br>sor |                            | Model              | Type         | Vierwiel-<br>aandrij-<br>ving |
| L300               | P03V<br>P13V               | 4G63-6<br>(2,0)  | x        | Enkel    | x                               | -                        | MPI                        | R5M21-2            | 5M/T         | -                             |
|                    | P05V<br>P05W<br>P15V       | 4D56-2<br>(2,5)  | x        | Enkel    | -                               | -                        | Diesel<br>S-RGS            | R5M21-2            | 5M/T         | -                             |
|                    | P04W                       | 4G64-3<br>(2,4)  | x        | Enkel    | x                               | -                        | MPI                        | R5M21-2            | 5M/T         | -                             |
|                    | P13T                       | 4G63-6<br>(2,0)  | x        | Enkel    | x                               | -                        | MPI                        | R5M21-8            | 5M/T         | -                             |
|                    | P15T                       | 4D56-2<br>(2,5)  | x        | Enkel    | -                               | x                        | Diesel<br>S-RGS            | R5M21-8            | 5M/T         | -                             |
| L300<br>4WD        | P25V<br>P25W<br>P45V       | 4D56-2<br>(2,5)  | x        | Enkel    | -                               | x                        | Diesel<br>S-RGS            | V5M21-2            | 5M/T         | x                             |
| L400               | PA3V<br>PB3V               | 4G63-6<br>(2,0)  | x        | Enkel    | x                               | -                        | MPI                        | R5M21-7            | 5M/T         | -                             |
|                    | PA5V<br>PB5V               | 4D56-2<br>(2,5)  | x        | Enkel    | -                               | x                        | Diesel<br>S-RGS            | R5M21-7            | 5M/T         | -                             |
|                    | PA3W                       | 4G63-6<br>(2,0)  | x        | Enkel    | x                               | -                        | MPI                        | R5M21-7<br>R4AW2-5 | 5M/T<br>4A/T | -<br>-                        |
|                    | PA4W                       | 4G64-2<br>(2,4)  | x        | Enkel    | x                               | -                        | MPI                        | R5M21-7<br>R4AW2-5 | 5M/T<br>4A/T | -<br>-                        |
|                    | PA5W                       | 4D56-2<br>(2,5)  | x        | Enkel    | -                               | x                        | Diesel<br>S-RGS            | R5M31-7            | 5M/T         | -                             |
|                    | PD4V<br>PD4W               | 4G64-2<br>(2,4)  | x        | Enkel    | x                               | -                        | MPI                        | V5M21-7            | 5M/T         | x                             |
|                    | PD5V                       | 4D56-2<br>(2,5)  | x        | Enkel    | -                               | x                        | Diesel<br>S-RGS            | V5M21-7            | 5M/T         | x                             |
| PD5W               | 4D56-2<br>(2,5)            | x                | Enkel    | -        | x                               | Diesel<br>S-RGS          | V5M31-7                    | 5M/T               | x            |                               |

## 1996 modellen voor Europa

| Voertuig-<br>model | Voertuig<br>model-<br>code | Motor            |          |          |                                 |                          | Brand-<br>stof-<br>systeem | Versnelingsbak |      |                               |
|--------------------|----------------------------|------------------|----------|----------|---------------------------------|--------------------------|----------------------------|----------------|------|-------------------------------|
|                    |                            | Model<br>(liter) | Balansas | Nokkenas | Hydrau-<br>lische<br>klepstoter | Turbo<br>compres-<br>sor |                            | Model          | Type | Vierwiel-<br>aandrij-<br>ving |
| 3000GT             | Z16A                       | 6G72-4<br>(3,0)  | -        | Vier     | x                               | x                        | MPI                        | W6MG1-0        | 6M/T | x                             |
|                    |                            |                  |          |          |                                 |                          |                            | W5MG1-3        | 5M/T | x                             |
| Eclipse            | D32A                       | 4G63-7<br>(2,0)  | x        | Dubbel   | x                               | -                        | MPI                        | F5M31-2        | 5M/T | -                             |

## 1996 modellen voor algemene export

| Voertuig-<br>model         | Voertuig<br>model-<br>code | Motor            |          |          |                                 |                          | Brand-<br>stof-<br>systeem | Versnelingsbak     |              |                               |
|----------------------------|----------------------------|------------------|----------|----------|---------------------------------|--------------------------|----------------------------|--------------------|--------------|-------------------------------|
|                            |                            | Model<br>(liter) | Balansas | Nokkenas | Hydrau-<br>lische<br>klepstoter | Turbo<br>compres-<br>sor |                            | Model              | Type         | Vierwiel-<br>aandrij-<br>ving |
| Colt                       | CA1A                       | 4G13-2<br>(1,3)  | -        | Enkel    | -                               | -                        | CARB                       | F5M21-1            | 5M/T         | -                             |
|                            | CA2A                       | 4G15-2<br>(1,5)  | -        | Enkel    | -                               | -                        | CARB                       | F5M21-1<br>F3A21-2 | 5M/T<br>3A/T | -<br>-                        |
|                            | CA5A                       | 4G93-1<br>(1,8)  | -        | Dubbel   | x                               | -                        | MPI                        | F5M22-2            | 5M/T         | -                             |
|                            | CJ1A                       | 4G13-5<br>(1,3)  | -        | Enkel    | -                               | -                        | CARB                       | F5M41-1            | 5M/T         | -                             |
|                            |                            | 4G13-3<br>(1,3)  | -        | Enkel    | -                               | -                        | MPI                        | F5M41-1            | 5M/T         | -                             |
|                            | CJ2A                       | 4G15-5<br>(1,5)  | -        | Enkel    | -                               | -                        | CARB                       | F5M41-1<br>F4A41-1 | 5M/T<br>4A/T | -<br>-                        |
|                            | CJ4A                       | 4G92-3<br>(1,6)  | -        | Enkel    | -                               | -                        | MPI                        | F5M41-1<br>F4A41-1 | 5M/T<br>4A/T | -<br>-                        |
|                            | CJ5A                       | 4G93-5<br>(1,8)  | -        | Dubbel   | x                               | -                        | MPI                        | F5M42-1            | 5M/T         | -                             |
| Lancer/<br>Lancer<br>Wagon | CB1A                       | 4G13-2<br>(1,3)  | -        | Enkel    | -                               | -                        | CARB                       | F5M21-1            | 5M/T         | -                             |
|                            | CB1W                       | 4G13-2<br>(1,3)  | -        | Enkel    | -                               | -                        | CARB                       | F5M21-1<br>F3A21-2 | 5M/T<br>3A/T | -<br>-                        |
|                            | CB2A<br>CB2W               | 4G15-2<br>(1,5)  | -        | Enkel    | -                               | -                        | CARB                       | F5M21-1<br>F3A21-2 | 5M/T<br>3A/T | -<br>-                        |
|                            | CK1A                       | 4G13-5<br>(1,3)  | -        | Enkel    | -                               | -                        | CARB                       | F5M41-1<br>F4A41-1 | 5M/T<br>4A/T | -<br>-                        |
|                            |                            | 4G13-3<br>(1,3)  | -        | Enkel    | -                               | -                        | MPI                        | F5M41-1<br>F4A41-1 | 5M/T<br>4A/T | -<br>-                        |
|                            | CK2A                       | 4G15-5<br>(1,5)  | -        | Enkel    | -                               | -                        | CARB                       | F5M41-1<br>F4A41-1 | 5M/T<br>4A/T | -<br>-                        |
|                            |                            | 4G15-4<br>(1,5)  | -        | Dubbel   | x                               | -                        | MPI                        | F5M41-1<br>F4A41-1 | 5M/T<br>4A/T | -<br>-                        |

## 1996 modellen voor algemene export

| Voertuig-<br>model         | Voertuig-<br>model-<br>code | Motor            |                 |          |                                 |                          | Brand-<br>stof-<br>systeem | Versnelingsbak     |                    |                               |
|----------------------------|-----------------------------|------------------|-----------------|----------|---------------------------------|--------------------------|----------------------------|--------------------|--------------------|-------------------------------|
|                            |                             | Model<br>(liter) | Balansas        | Nokkenas | Hydrau-<br>lische<br>klepstoter | Turbo<br>compres-<br>sor |                            | Model              | Type               | Vierwiel-<br>aandrij-<br>ving |
| Lancer/<br>Lancer<br>Wagon | CK4A                        | 4G92-3<br>(1,6)  | -               | Enkel    | -                               | -                        | MPI                        | F5M41-1<br>F4A41-1 | 5M/T<br>4A/T       | -<br>-                        |
|                            |                             | 4G92-7<br>(1,6)  | -               | Dubbel   | -                               | -                        | MPI                        | F5M42-1<br>F4A42-1 | 5M/T<br>4A/T       | -<br>-                        |
| Space<br>Runner            | N11W                        | 4G93-0<br>(1,8)  | -               | Enkel    | -                               | -                        | MPI                        | F5M22-1<br>F4A22-2 | 5M/T<br>4A/T       | -<br>-                        |
| Space<br>Wagon             | N31W                        | 4G93-0<br>(1,8)  | -               | Enkel    | -                               | -                        | CARB                       | F5M22-1<br>F4A22-2 | 5M/T<br>4A/T       | -<br>-                        |
|                            | N33W                        | 4G63-6<br>(2,0)  | x               | Enkel    | x                               | -                        | MPI                        | F5M22-1<br>F4A22-2 | 5M/T<br>4A/T       | -<br>-                        |
| Galant                     | E52A                        | 4G93-0<br>(1,8)  | -               | Enkel    | -                               | -                        | CARB                       | F5M22-2<br>F4A22-2 | 5M/T<br>4A/T       | -<br>-                        |
|                            |                             |                  |                 |          |                                 |                          | MPI                        | F5M22-2<br>F4A22-2 | 5M/T<br>4A/T       | -<br>-                        |
|                            | E54A                        | 6A12-0<br>(2,0)  | -               | Vier     | x                               | -                        | MPI                        | F5M31-2<br>F4A23-2 | 5M/T<br>4A/T       | -<br>-                        |
|                            | E55A                        | 4G63-6<br>(2,0)  | x               | Enkel    | x                               | -                        | CARB                       | F5M22-2<br>F4A22-2 | 5M/T<br>4A/T       | -<br>-                        |
|                            |                             |                  |                 |          |                                 |                          | MPI                        | F5M22-2<br>F4A22-2 | 5M/T<br>4A/T       | -<br>-                        |
|                            |                             |                  | 4G63-D<br>(2,0) | x        | Enkel                           | x                        | -                          | CARB               | F5M22-2<br>F4A22-2 | 5M/T<br>4A/T                  |
| Sigma                      | F16A                        | 6G72-1<br>(3,0)  | -               | Dubbel   | x                               | -                        | MPI                        | F5M33-2<br>F4A33-1 | 5M/T<br>4A/T       | -<br>-                        |
|                            |                             | 6G72-4<br>(3,0)  | -               | Vier     | x                               | -                        | MPI                        | F5M33-2<br>F4A33-1 | 5M/T<br>4A/T       | -<br>-                        |
| Pajero/<br>Montero         | V12V<br>V12W<br>V32V        | 4G54-1<br>(2,6)  | -               | Enkel    | -                               | -                        | CARB                       | V5M21-6            | 5M/T               | x                             |
|                            | V32W                        | 4G54-1<br>(2,6)  | -               | Enkel    | -                               | -                        | CARB                       | V5M21-6<br>V4AW2-7 | 5M/T<br>4A/T       | x<br>x                        |
|                            | V13V<br>V33V                | 6G72-1<br>(3,0)  | -               | Dubbel   | x                               | -                        | MPI                        | V5MT1-6            | 5M/T               | x                             |

1996 modellen voor algemene export

| Voertuig-<br>model | Voertuig<br>model-<br>code | Motor            |          |          |                                 |                          | Brand-<br>stof-<br>systeem | Versnelingsbak     |              |                               |
|--------------------|----------------------------|------------------|----------|----------|---------------------------------|--------------------------|----------------------------|--------------------|--------------|-------------------------------|
|                    |                            | Model<br>(liter) | Balansas | Nokkenas | Hydrau-<br>lische<br>klepstoter | Turbo<br>compres-<br>sor |                            | Model              | Type         | Vierwiel-<br>aandrij-<br>ving |
| Pajero/<br>Montero | V23W<br>V43W               | 6G72-1<br>(3,0)  | -        | Dubbel   | x                               | -                        | MPI                        | V5MT1-6<br>V4AW2-7 | 5M/T<br>4A/T | x<br>x                        |
|                    | V14C<br>V14V<br>V34V       | 4D56-2<br>(2,5)  | x        | Enkel    | -                               | -                        | Diesel<br>S-RGS            | V5M21-6            | 5M/T         | x                             |
|                    | V24W                       | 4D56-2<br>(2,5)  | x        | Enkel    | -                               | x                        | Diesel<br>S-RGS            | V5MT1-6            | 5M/T         | x                             |
|                    | V44W                       | 4D56-2<br>(2,5)  | x        | Enkel    | -                               | x                        | Diesel<br>S-RGS            | V5MT1-6<br>V4AW2-7 | 5M/T<br>4A/T | x<br>x                        |
|                    | V25W<br>V45W               | 6G74-1<br>(3,5)  | -        | Vier     | x                               | -                        | MPI                        | V5M31-5<br>V4AW3-7 | 5M/T<br>4A/T | x<br>x                        |
|                    | V36V<br>V36W               | 4M40<br>(2,8)    | x        | Enkel    | -                               | -                        | Diesel<br>S-RGS            | V5M31-5            | 5M/T         | x                             |
|                    | V46W                       | 4M40<br>(2,8)    | x        | Enkel    | -                               | x                        | Diesel<br>S-RGS            | V5M31-5<br>V4AW3-7 | 5M/T<br>4A/T | x<br>x                        |
| L200               | K11T                       | 4G32-8<br>(1,6)  | -        | Enkel    | -                               | -                        | CARB                       | R4M21-1            | 4M/T         | -                             |
|                    | K02T<br>K12T               | 4G63-8<br>(2,0)  | -        | Enkel    | -                               | -                        | CARB                       | R5M21-1            | 5M/T         | -                             |
|                    | K03T<br>K13T               | 4G54-1<br>(2,6)  | -        | Enkel    | -                               | -                        | CARB                       | R5M21-1            | 5M/T         | -                             |
|                    | K14T                       | 4D56-2<br>(2,5)  | x        | Enkel    | -                               | -                        | Diesel<br>S-RGS            | R5M21-1            | 5M/T         | -                             |
|                    | K15T                       | 4G64-3<br>(2,4)  | x        | Enkel    | x                               | -                        | MPI                        | R5M21-1            | 5M/T         | -                             |
| L200<br>4WD        | K24T                       | 4D56-2<br>(2,5)  | x        | Enkel    | -                               | -                        | Diesel<br>S-RGS            | V5M21-1            | 5M/T         | x                             |
|                    | K34T                       | 4D56-2<br>(2,5)  | x        | Enkel    | -                               | -                        | Diesel<br>S-RGS            | V5M21-1            | 5M/T         | x                             |
|                    |                            |                  |          |          |                                 | x                        | Diesel<br>S-RGS            | V5M21-1            | 5M/T         | x                             |



## 1996 modellen voor algemene export

| Voertuig-<br>model | Voertuig<br>model-<br>code | Motor            |          |          |                                 |                          | Brand-<br>stof-<br>systeem | Versnelingsbak     |              |                               |
|--------------------|----------------------------|------------------|----------|----------|---------------------------------|--------------------------|----------------------------|--------------------|--------------|-------------------------------|
|                    |                            | Model<br>(liter) | Balansas | Nokkenas | Hydrau-<br>lische<br>klepstoter | Turbo<br>compres-<br>sor |                            | Model              | Type         | Vierwiel-<br>aandrij-<br>ving |
| L200<br>4WD        | K32T                       | 4G63-8<br>(2,0)  | -        | Enkel    | -                               | -                        | CARB                       | V5M21-1            | 5M/T         | ×                             |
|                    | K35T                       | 4G64-3<br>(2,4)  | ×        | Enkel    | ×                               | -                        | MPI                        | V5M21-1            | 5M/T         | ×                             |
| L300               | P03V<br>P13W               | 4G63-B<br>(2,0)  | -        | Enkel    | ×                               | -                        | CARB                       | R5M21-2            | 5M/T         | -                             |
|                    | P13V                       | 4G63-B<br>(2,0)  | -        | Enkel    | ×                               | -                        | CARB                       | R5M21-2            | 5M/T         | -                             |
|                    |                            | 4G63-6<br>(2,0)  | ×        | Enkel    | ×                               | -                        | MPI                        | R5M21-2            | 5M/T         | -                             |
|                    | P03W                       | 4G63-8<br>(2,0)  | -        | Enkel    | -                               | -                        | CARB                       | R5M21-2            | 5M/T         | -                             |
|                    | P15V<br>P15W               | 4D56-2<br>(2,5)  | ×        | Enkel    | -                               | -                        | Diesel<br>S-RGS            | R5M21-2            | 5M/T         | -                             |
|                    | P06V<br>P16V               | 4G92-0<br>(1,6)  | -        | Enkel    | -                               | -                        | CARB                       | R5M21-2            | 5M/T         | -                             |
| ELEC<br>CARB       |                            |                  |          |          |                                 |                          | R5M21-2                    | 5M/T               | -            |                               |
| L300<br>4WD        | P23W                       | 4G63-8<br>(2,0)  | -        | Enkel    | -                               | -                        | CARB                       | V5M21-2            | 5M/T         | ×                             |
|                    |                            | 4G63-B<br>(2,0)  | -        | Enkel    | ×                               | -                        | CARB                       | V5M21-2            | 5M/T         | ×                             |
| L400               | PA3V<br>PB3V               | 4G63-B<br>(2,0)  | -        | Enkel    | ×                               | -                        | CARB                       | R5M21-7            | 5M/T         | -                             |
|                    |                            | 4G63-A<br>(2,0)  | ×        | Enkel    | ×                               | -                        | ELEC<br>CARB               | R5M21-7            | 5M/T         | -                             |
|                    | PA3W                       | 4G63-B<br>(2,0)  | -        | Enkel    | ×                               | -                        | CARB                       | R5M21-7<br>R4AW2-5 | 5M/T<br>4A/T | -<br>-                        |
|                    |                            | 4G63-6<br>(2,0)  | ×        | Enkel    | ×                               | -                        | MPI                        | R5M21-7            | 5M/T         | -                             |

## 1996 modellen voor algemene export

| Voertuig-<br>model | Voertuig-<br>model-<br>code | Motor            |          |          |                                 |                          | Brand-<br>stof-<br>systeem | Versnelingsbak     |              |                               |
|--------------------|-----------------------------|------------------|----------|----------|---------------------------------|--------------------------|----------------------------|--------------------|--------------|-------------------------------|
|                    |                             | Model<br>(liter) | Balansas | Nokkenas | Hydrau-<br>lische<br>klepstoter | Turbo<br>compres-<br>sor |                            | Model              | Type         | Vierwiel-<br>aandrij-<br>ving |
| L400               | PB4V                        | 4G64-2<br>(2,4)  | ×        | Enkel    | ×                               | –                        | MPI                        | R5M21-7            | 5M/T         | –                             |
|                    | PA4W                        | 4G64-2<br>(2,4)  | ×        | Enkel    | ×                               | –                        | MPI                        | R4AW2-5            | 4A/T         | –                             |
|                    | PC3W                        | 4G63-B<br>(2,0)  | –        | Enkel    | ×                               | –                        | CARB                       | R5M21-7            | 5M/T         | –                             |
|                    | PB5V                        | 4D56-2<br>(2,5)  | ×        | Enkel    | –                               | ×                        | Diesel<br>S-RGS            | R5M21-7            | 5M/T         | –                             |
|                    | PA5W<br>PC5W                | 4D56-2<br>(2,5)  | ×        | Enkel    | –                               | ×                        | Diesel<br>S-RGS            | R5M21-7<br>R4AW2-5 | 5M/T<br>4A/T | –<br>–                        |
|                    | PD3W                        | 4G63-B<br>(2,0)  | –        | Enkel    | ×                               | –                        | CARB                       | V5M21-7            | 5M/T         | ×                             |
|                    | PD4W                        | 4G64-2<br>(2,4)  | ×        | Enkel    | ×                               | –                        | MPI                        | V5M21-7            | 5M/T         | ×                             |
|                    | PD5W                        | 4D56-2<br>(2,5)  | ×        | Enkel    | –                               | ×                        | Diesel<br>S-RGS            | V5M21-7            | 5M/T         | ×                             |
| 3000GT             | Z16A                        | 6G72-4<br>(3,0)  | –        | Vier     | ×                               | ×                        | MPI                        | W5MG1-2            | 5M/T         | ×                             |

## 1996 modellen voor Australië

| Voertuig-<br>model         | Voertuig<br>model-<br>code | Motor            |          |          |                                 |                          | Brand-<br>stof-<br>systeem | Versnelingsbak     |              |                               |
|----------------------------|----------------------------|------------------|----------|----------|---------------------------------|--------------------------|----------------------------|--------------------|--------------|-------------------------------|
|                            |                            | Model<br>(liter) | Balansas | Nokkenas | Hydrau-<br>lische<br>klepstoter | Turbo<br>compres-<br>sor |                            | Model              | Type         | Vierwiel-<br>aandrij-<br>ving |
| Lancer/<br>Lancer<br>Wagon | CA2A<br>CB2A               | 4G15-2<br>(1,5)  | –        | Enkel    | –                               | –                        | CARB                       | F5M21-1<br>F3A21-2 | 5M/T<br>3A/T | –<br>–                        |
|                            | CA5A<br>CB5A<br>CB5W       | 4G93-0<br>(1,8)  | –        | Enkel    | –                               | –                        | MPI                        | F5M22-2<br>F4A22-2 | 5M/T<br>4A/T | –<br>–                        |
| Space<br>Wagon             | N34W                       | 4G64-2<br>(2,4)  | ×        | Enkel    | ×                               | –                        | MPI                        | F5M31-2<br>F4A23-2 | 5M/T<br>4A/T | –<br>–                        |
| Galant                     | E54A                       | 6A12-0<br>(2,0)  | –        | Vier     | ×                               | –                        | MPI                        | F5M31-2<br>F4A23-2 | 5M/T<br>4A/T | –<br>–                        |
|                            | E55A                       | 4G63-6<br>(2,0)  | ×        | Enkel    | ×                               | –                        | MPI                        | F5M31-2<br>F4A23-2 | 5M/T<br>4A/T | –<br>–                        |
| Pajero/<br>Montero         | V23W<br>V43W               | 6G72-1<br>(3,0)  | –        | Dubbel   | ×                               | –                        | MPI                        | V5MT1-6<br>V4AW2-7 | 5M/T<br>4A/T | ×                             |
|                            | V36W                       | 4M40<br>(2,8)    | ×        | Enkel    | –                               | ×                        | Diesel<br>S-RGS            | V5M21-6            | 5M/T         | ×                             |
|                            | V46W                       | 4M40<br>(2,8)    | ×        | Enkel    | –                               | ×                        | Diesel<br>S-RGS            | V5M31-5            | 5M/T         | ×                             |
|                            | V45W                       | 6G74-1<br>(3,5)  | –        | Vier     | ×                               | –                        | MPI                        | F4AW3-7            | 4A/T         | –                             |
| L200                       | K13T                       | 4G54-1<br>(2,6)  | ×        | Enkel    | ×                               | –                        | CARB                       | R5M21-1            | 5M/T         | –                             |
|                            | K14T                       | 4D56-2<br>(2,5)  | ×        | Enkel    | –                               | –                        | Diesel<br>S-RGS            | R5M21-1            | 5M/T         | –                             |
| L200<br>4WD                | K33T                       | 4G54-1<br>(2,6)  | –        | Enkel    | –                               | –                        | CARB                       | V5M21-1            | 5M/T         | ×                             |
|                            | K34T                       | 4D56-2<br>(2,5)  | ×        | Enkel    | –                               | ×                        | Diesel<br>S-RGS            | V5M21-1            | 5M/T         | ×                             |
|                            | K36T                       | 6G72-1<br>(3,0)  | –        | Enkel    | ×                               | –                        | MPI                        | V5MT1-2            | 5M/T         | ×                             |

## 1996 modellen voor Australië

| Voertuig-<br>model | Voertuig<br>model-<br>code | Motor            |          |          |                                 |                          | Brand-<br>stof-<br>systeem | Versnelingsbak     |              |                               |
|--------------------|----------------------------|------------------|----------|----------|---------------------------------|--------------------------|----------------------------|--------------------|--------------|-------------------------------|
|                    |                            | Model<br>(liter) | Balansas | Nokkenas | Hydrau-<br>lische<br>klepstoter | Turbo<br>compres-<br>sor |                            | Model              | Type         | Vierwiel-<br>aandrij-<br>ving |
| L300               | P03V                       | 4G63-9<br>(2,0)  | ×        | Enkel    | ×                               | –                        | CARB                       | R5M21-2<br>R4AW2-2 | 5M/T<br>4A/T | –<br>–                        |
|                    |                            | 4G63-A<br>(2,0)  | ×        | Enkel    | ×                               | –                        | CARB                       | R5M21-2<br>R4AW2-8 | 5M/T<br>4A/T | –<br>–                        |
|                    | P03W                       | 4G63-9<br>(2,0)  | ×        | Enkel    | ×                               | –                        | CARB                       | R5M21-2<br>R4AW2-2 | 5M/T<br>4A/T | –<br>–                        |
|                    | P05V<br>P15V               | 4D56-2<br>(2,5)  | ×        | Enkel    | –                               | –                        | Diesel<br>S-RGS            | R5M21-5<br>R4AW2-8 | 5M/T<br>4A/T | –<br>–                        |
|                    | P14V                       | 4G64-2<br>(2,4)  | ×        | Enkel    | ×                               | –                        | MPI                        | R5M21-2<br>R4AW2-8 | 5M/T<br>4A/T | –<br>–                        |
| L300<br>4WD        | P24V                       | 4G64-2<br>(2,4)  | ×        | Enkel    | ×                               | –                        | MPI                        | V5M21-2            | 5M/T         | ×                             |
| L400               | PB4V<br>PA4W               | 4G64-2<br>(2,4)  | ×        | Enkel    | ×                               | –                        | MPI                        | R5M21-7<br>R4AW2-5 | 5M/T<br>4A/T | –<br>–                        |
|                    | PA3W                       | 4G63-A<br>(2,0)  | ×        | Enkel    | ×                               | –                        | CARB                       | R5M21-7<br>R4AW2-5 | 5M/T<br>4A/T | –<br>–                        |
|                    | PB6W                       | 6G72-8<br>(3,0)  | –        | Dubbel   | ×                               | –                        | MPI                        | R4AW3-5            | 4A/T         | –                             |
| 3000GT             | Z16A                       | 6G72-4<br>(3,0)  | –        | Vier     | ×                               | ×                        | MPI                        | W5MG1-2            | 5M/T         | ×                             |

## 1997 modellen voor Europa

| Voertuig-<br>model | Voertuig<br>model-<br>code | Motor            |          |          |                                 |                          | Brand-<br>stof-<br>systeem | Versnelingsbak     |              |                               |
|--------------------|----------------------------|------------------|----------|----------|---------------------------------|--------------------------|----------------------------|--------------------|--------------|-------------------------------|
|                    |                            | Model<br>(liter) | Balansas | Nokkenas | Hydrau-<br>lische<br>klepstoter | Turbo<br>compres-<br>sor |                            | Model              | Type         | Vierwiel-<br>aandrij-<br>ving |
| Colt               | CJ1A                       | 4G13-3<br>(1,3)  | -        | Enkel    | -                               | -                        | MPI                        | F5M41-1<br>F4A41-1 | 5M/T<br>4A/T | -<br>-                        |
|                    |                            | 4G92-3<br>(1,6)  | -        | Enkel    | -                               | -                        | MPI                        | F5M41-1<br>F4A41-1 | 5M/T<br>4A/T | -<br>-                        |
|                    | 4G92-8<br>(1,6)            | -                | Enkel    | -        | -                               | MPI                      | F5M41-1                    | 5M/T               | -            |                               |
| Lancer             | CB4W                       | 4G92-0<br>(1,6)  | -        | Enkel    | -                               | -                        | MPI                        | F5M22-2<br>F4A22-2 | 5M/T<br>4A/T | -<br>-                        |
|                    | CD4W                       | 4G92-0<br>(1,6)  | -        | Enkel    | -                               | -                        | MPI                        | W5M31-2            | 4A/T         | x                             |
|                    | CK1A                       | 4G13-3<br>(1,3)  | -        | Enkel    | -                               | -                        | MPI                        | F5M41-1<br>F4A41-1 | 5M/T<br>4A/T | -<br>-                        |
|                    | CK4A                       | 4G92-3<br>(1,6)  | -        | Enkel    | -                               | -                        | MPI                        | F5M41-1<br>F4A41-1 | 5M/T<br>4A/T | -<br>-                        |
| Carisma            | DA1A                       | 4G92-2<br>(1,6)  | -        | Enkel    | -                               | -                        | MPI                        | F5MR1<br>F4A42-1   | 5M/T<br>4A/T | -<br>-                        |
|                    | DA2A                       | 4G93-2<br>(1,8)  | -        | Enkel    | -                               | -                        | MPI                        | F5MR1<br>F4A42-1   | 5M/T<br>4A/T | -<br>-                        |
|                    |                            | 4G93-4<br>(1,8)  | -        | Dubbel   | x                               | -                        | MPI                        | F5MR1              | 5M/T         | -                             |
|                    | DA4A                       | F8QT<br>(1,8)    | -        | Enkel    | -                               | -                        | MPI                        | F5MR1              | 5M/T         | -                             |
| Space<br>Runner    | N11W                       | 4G93-0<br>(1,8)  | -        | Enkel    | -                               | -                        | MPI                        | F5M22-1<br>F4A22-2 | 5M/T<br>4A/T | -<br>-                        |
|                    | N18W                       | 4D68-0<br>(2,0)  | x        | Enkel    | -                               | x                        | Diesel<br>S-RGS            | F5M31-1            | 5M/T         | -                             |
|                    | N21W                       | 4G93-0<br>(1,8)  | -        | Enkel    | -                               | -                        | MPI                        | W5M31-2            | 5M/T         | x                             |
| Space<br>Wagon     | N33W                       | 4G63-6<br>(2,0)  | x        | Enkel    | x                               | -                        | MPI                        | F5M22-1<br>F4A22-2 | 5M/T<br>4A/T | -<br>-                        |

## 1997 modellen voor Europa

| Voertuig-<br>model | Voertuig<br>model-<br>code | Motor            |          |          |                                 |                          | Brand-<br>stof-<br>systeem | Versnelingsbak     |              |                               |
|--------------------|----------------------------|------------------|----------|----------|---------------------------------|--------------------------|----------------------------|--------------------|--------------|-------------------------------|
|                    |                            | Model<br>(liter) | Balansas | Nokkenas | Hydrau-<br>lische<br>klepstoter | Turbo<br>compres-<br>sor |                            | Model              | Type         | Vierwiel-<br>aandrij-<br>ving |
| Space<br>Wagon     | N34W                       | 4G64-2<br>(2,4)  | ×        | Enkel    | ×                               | –                        | MPI                        | F5M22-1<br>F4A23-2 | 5M/T<br>4A/T | –<br>–                        |
|                    | N38W                       | 4D68-0<br>(2,0)  | ×        | Enkel    | ×                               | –                        | Diesel<br>S-RGS            | F5M31-1            | 5M/T         | –                             |
|                    | N43W                       | 4G63-6<br>(2,0)  | ×        | Enkel    | –                               | ×                        | MPI                        | W5M31-2<br>W4A32-1 | 5M/T<br>4A/T | ×                             |
| GALANT             | EA2A<br>EA2W               | 4G63-6<br>(2,0)  | ×        | Enkel    | ×                               | –                        | MPI                        | F5M42-1<br>F4A42-1 | 5M/T<br>4A/T | –<br>–                        |
|                    | EA5A<br>EA5W               | 6A13-4<br>(2,5)  | –        | Dubbel   | ×                               | –                        | MPI                        | F5M42-2<br>F4A42-2 | 5M/T<br>4A/T | –<br>–                        |
|                    | EA6A<br>EA6W               | 4D68-4<br>(2,0)  | ×        | Enkel    | –                               | ×                        | Diesel<br>S-RGS            | F5M42-2<br>F4A42-2 | 5M/T<br>4A/T | –<br>–                        |
| Pajero/<br>Montero | V23C<br>V23W<br>V43W       | 6G72-8<br>(3,0)  | –        | Dubbel   | ×                               | –                        | MPI                        | V5MT1-6<br>V4AW3-7 | 5M/T<br>4A/T | ×                             |
|                    | V24C<br>V24W<br>V44W       | 4D56-2<br>(2,5)  | ×        | Enkel    | –                               | ×                        | Diesel<br>S-RGS            | V5MT1-6            | 5M/T         | ×                             |
|                    | V25W<br>V45W               | 6G74-1<br>(3,5)  | –        | Vier     | ×                               | –                        | MPI                        | V5M31-5<br>V4AW3-7 | 5M/T<br>4A/T | ×                             |
|                    | V26W<br>V46W               | 4M40<br>(2,8)    | ×        | Enkel    | –                               | ×                        | Diesel<br>S-RGS            | V5M31-5<br>V4AW3-7 | 5M/T<br>4A/T | ×                             |
| L200               | K14T                       | 4D56-2<br>(2,5)  | ×        | Enkel    | –                               | –                        | Diesel<br>S-RGS            | R5M21-1            | 5M/T         | –                             |
|                    | K15T                       | 4G64-3<br>(2,4)  | ×        | Enkel    | ×                               | –                        | MPI                        | R5M21-1            | 5M/T         | –                             |
|                    | K24T<br>K34T               | 4D56-2<br>(2,5)  | ×        | Enkel    | –                               | ×                        | Diesel<br>S-RGS            | V5M21-1            | 5M/T         | ×                             |
|                    | K35T                       | 4D64-3<br>(2,4)  | ×        | Enkel    | ×                               | –                        | MPI                        | V5M21-1            | 5M/T         | ×                             |
|                    | K62T                       | 4G63-6<br>(2,0)  | ×        | Enkel    | ×                               | –                        | MPI                        | R5M21-5<br>R4AW2-6 | 5M/T<br>4A/T | –<br>–                        |

## 1997 modellen voor Europa

| Voertuig-<br>model | Voertuig-<br>model-<br>code  | Motor            |          |          |                                 |                          | Brand-<br>stof-<br>systeem | Versnelingsbak     |              |                               |
|--------------------|------------------------------|------------------|----------|----------|---------------------------------|--------------------------|----------------------------|--------------------|--------------|-------------------------------|
|                    |                              | Model<br>(liter) | Balansas | Nokkenas | Hydrau-<br>lische<br>klepstoter | Turbo<br>compres-<br>sor |                            | Model              | Type         | Vierwiel-<br>aandrij-<br>ving |
| L200               | K64T                         | 4D56-3<br>(2,5)  | x        | Enkel    | –                               | x                        | Diesel<br>S-RGS            | R5M21-5            | 5M/T         | –                             |
|                    | K75T                         | 4G64-2<br>(2,4)  | x        | Enkel    | x                               | –                        | MPI                        | V5M21-9            | 5M/T         | x                             |
|                    | K74T                         | 4D56-3<br>(2,5)  | x        | Enkel    | –                               | x                        | Diesel<br>S-RGS            | V5MT1-4<br>V4AW2-6 | 5M/T<br>4A/T | x<br>x                        |
| L300               | P03V<br>P03W<br>P13T<br>P13V | 4G63-6<br>(2,0)  | x        | Enkel    | x                               | –                        | MPI                        | R5M21-8            | 5M/T         | –                             |
|                    | P05V<br>P05W<br>P15T<br>P15V | 4D56-2<br>(2,5)  | x        | Enkel    | –                               | x                        | Diesel<br>S-RGS            | R5M21-8            | 5M/T         | –                             |
|                    | P25V<br>P45V                 | 4D56-2<br>(2,5)  | x        | Enkel    | –                               | x                        | Diesel<br>S-RGS            | V5M21-8            | 5M/T         | x                             |
| L400               | PA3V<br>PB3V                 | 4G63-6<br>(2,0)  | x        | Enkel    | x                               | –                        | MPI                        | R5M21-7            | 5M/T         | –                             |
|                    | PA5V<br>PB5V                 | 4D56-2<br>(2,5)  | x        | Enkel    | –                               | x                        | Diesel<br>S-RGS            | R5M21-7            | 5M/T         | –                             |
|                    | PD4V                         | 4G64-2<br>(2,4)  | x        | Enkel    | x                               | –                        | MPI                        | V5M21-7            | 5M/T         | x                             |
|                    | PD5V                         | 4D56-2<br>(2,5)  | x        | Enkel    | –                               | x                        | Diesel<br>S-RGS            | V5M21-7            | 5M/T         | x                             |
| Space<br>Gear      | PA3W                         | 4G63-6<br>(2,0)  | x        | Enkel    | x                               | –                        | MPI                        | R5M21-7<br>R4AW2-5 | 5M/T         | –                             |
|                    | PA4W                         | 4G64-2<br>(2,4)  | x        | Enkel    | x                               | –                        | MPI                        | R5M21-7<br>R4AW2-5 | 5M/T<br>4A/T | –<br>–                        |
|                    | PA5W                         | 4D56-2<br>(2,5)  | x        | Enkel    | –                               | x                        | Diesel<br>S-RGS            | R5M31-7            | 5M/T         | –                             |

## 1997 modellen voor Europa

| Voertuig-<br>model | Voertuig<br>model-<br>code | Motor            |          |          |                                 |                          | Brand-<br>stof-<br>systeem | Versnelingsbak |      |                               |
|--------------------|----------------------------|------------------|----------|----------|---------------------------------|--------------------------|----------------------------|----------------|------|-------------------------------|
|                    |                            | Model<br>(liter) | Balansas | Nokkenas | Hydrau-<br>lische<br>klepstoter | Turbo<br>compres-<br>sor |                            | Model          | Type | Vierwiel-<br>aandrij-<br>ving |
| Space<br>Gear      | PD4W                       | 6G64-2<br>(2,4)  | x        | Enkel    | x                               | -                        | MPI                        | V5M21-7        | 5M/T | x                             |
|                    | PD5W                       | 4D56-2<br>(2,5)  | x        | Enkel    | -                               | x                        | Diesel<br>S-RGS            | V5M31-7        | 5M/T | x                             |
| 3000GT             | Z16A                       | 6G72-4<br>(3,0)  | -        | Vier     | x                               | x                        | MPI                        | W6MG1-0        | 6M/T | x                             |
| Eclipse            | D32A                       | 4G63-7<br>(2,0)  | x        | Dubbel   | x                               | -                        | MPI                        | F5M31-2        | 5M/T | -                             |



## 1997 modellen voor algemene export

| Voertuig-<br>model | Voertuig<br>model-<br>code | Motor            |                 |          |                                 |                          | Brand-<br>stof-<br>systeem | Versnelingsbak     |                    |                               |
|--------------------|----------------------------|------------------|-----------------|----------|---------------------------------|--------------------------|----------------------------|--------------------|--------------------|-------------------------------|
|                    |                            | Model<br>(liter) | Balansas        | Nokkenas | Hydrau-<br>lische<br>klepstoter | Turbo<br>compres-<br>sor |                            | Model              | Type               | Vierwiel-<br>aandrij-<br>ving |
| Colt               | CJ1A                       | 4G13-3<br>(1,3)  | -               | Enkel    | -                               | -                        | CARB                       | F5M41-1            | 5M/T               | -                             |
|                    |                            | 4G13-3<br>(1,3)  | -               | Enkel    | -                               | -                        | MPI                        | F5M41-1            | 5M/T               | -                             |
|                    | CJ2A                       | 4G15-5<br>(1,5)  | -               | Enkel    | -                               | -                        | CARB                       | F5M41-1            | 5M/T               | -                             |
|                    | CJ4A                       | 4G92-3<br>(1,6)  | -               | Enkel    | -                               | -                        | MPI                        | F5M41-1<br>F4A41-1 | 5M/T<br>4A/T       | -<br>-                        |
| Lancer             | CB1W                       | 4G13-2<br>(1,3)  | -               | Enkel    | -                               | -                        | CARB                       | F5M21-1<br>F3A21-2 | 5M/T<br>3A/T       | -<br>-                        |
|                    |                            | CB2W             | 4G15-2<br>(1,5) | -        | Enkel                           | -                        | -                          | CARB               | F5M21-1<br>F3A21-2 | 5M/T<br>3A/T                  |
|                    | CB4W                       | 4G92-0<br>(1,6)  | -               | Enkel    | -                               | -                        | MPI                        | F5M22-2<br>F4A22-2 | 5M/T<br>4A/T       | -<br>-                        |
|                    | CK1A                       | 4G13-3<br>(1,3)  | -               | Enkel    | -                               | -                        | CARB                       | F5M41-1<br>F4A41-1 | 5M/T<br>4A/T       | -<br>-                        |
|                    |                            | 4G13-3<br>(1,3)  | -               | Enkel    | -                               | -                        | MPI                        | F5M41-1<br>F4A41-1 | 5M/T<br>4A/T       | -<br>-                        |
|                    | CK2A                       | 4G15-5<br>(1,5)  | -               | Enkel    | -                               | -                        | MPI                        | F5M41-1<br>F4A41-1 | 5M/T<br>4A/T       | -<br>-                        |
|                    |                            | 4G15-4<br>(1,5)  | -               | Dubbel   | -                               | -                        | MPI                        | F5M41-1<br>F4A41-1 | 5M/T<br>4A/T       | -<br>-                        |
|                    | CK4A                       | 4G92-3<br>(1,6)  | -               | Enkel    | -                               | -                        | MPI                        | F5M41-1<br>F4A41-1 | 5M/T<br>4A/T       | -<br>-                        |
| 4G92-7<br>(1,6)    |                            | -                | Dubbel          | -        | -                               | MPI                      | F5M42-1<br>F4A42-1         | 5M/T<br>4A/T       | -<br>-             |                               |
| Space<br>Runner    | N11W                       | 4G93-0<br>(1,8)  | -               | Enkel    | -                               | -                        | MPI                        | F5M22-1<br>F4A22-2 | 5M/T<br>4A/T       | -<br>-                        |
| Space<br>Wagon     | N31W                       | 4G93-0<br>(1,8)  | -               | Enkel    | -                               | -                        | CARB                       | F5M22-1<br>F4A22-2 | 5M/T<br>4A/T       | -<br>-                        |

## 1997 modellen voor algemene export

| Voertuig-<br>model | Voertuig<br>model-<br>code | Motor            |          |          |                                 |                          | Brand-<br>stof-<br>systeem | Versnelingsbak     |              |                               |
|--------------------|----------------------------|------------------|----------|----------|---------------------------------|--------------------------|----------------------------|--------------------|--------------|-------------------------------|
|                    |                            | Model<br>(liter) | Balansas | Nokkenas | Hydrau-<br>lische<br>klepstoter | Turbo<br>compres-<br>sor |                            | Model              | Type         | Vierwiel-<br>aandrij-<br>ving |
| Space<br>Wagon     | N33W                       | 4G63-6<br>(2,0)  | x        | Enkel    | x                               | -                        | MPI                        | F5M22-1            | 5M/T         | -                             |
|                    |                            |                  |          |          |                                 |                          |                            | F4A22-2            | 4A/T         | -                             |
| Galant             | EA1A                       | 4G93-9<br>(1,8)  | -        | Enkel    | -                               | -                        | CARB                       | F5M42-1<br>F4A42-1 | 5M/T<br>4A/T | -<br>-                        |
|                    | EA2A                       | 4G63-6<br>(2,0)  | x        | Enkel    | x                               | -                        | CARB                       | F5M42-1<br>F4A42-1 | 5M/T<br>4A/T | -<br>-                        |
|                    |                            | 4G63-6<br>(2,0)  | x        | Enkel    | x                               | -                        | MPI                        | F5M42-1<br>F4A42-1 | 5M/T<br>4A/T | -<br>-                        |
|                    | EA5A                       | 6A13-4<br>(2,5)  | -        | Dubbel   | x                               | -                        | MPI                        | F5M42-2<br>F4A42-2 | 5M/T<br>4A/T | -<br>-                        |
| Pajero/<br>Montero | V11V<br>V31V               | 4G64-6           | x        | Enkel    | x                               | -                        | CARB                       | V5M21-6            | 5M/T         | x<br>x                        |
|                    | V13V<br>V33V               | 6G72-1<br>(3,0)  | -        | Dubbel   | x                               | -                        | MPI                        | V5MT1-6            | 5M/T         | x                             |
|                    | V14V<br>V14C<br>V34V       | 4D56-2<br>(2,5)  | x        | Enkel    | -                               | -                        | Diesel<br>S-RGS            | V5M21-6            | 5M/T         | x                             |
|                    | V11W<br>V31V               | 4G64-2           | x        | Enkel    | x                               | -                        | MPI                        | V5M21-6            | 5M/T         | x                             |
|                    | V31W                       | 4G64-2           | x        | Enkel    | x                               | -                        | MPI                        | V5M21-6<br>V4AW2-A | 5M/T<br>4A/T | x<br>x                        |
|                    | V23W                       | 6G72-1<br>(3,0)  | -        | Dubbel   | x                               | -                        | MPI                        | V5MT1-6<br>V4AW2-2 | 5M/T<br>4A/T | x<br>x                        |
|                    | V24W<br>V44W               | 4D56-2<br>(2,5)  | x        | Enkel    | -                               | x                        | Diesel<br>S-RGS            | V5MT1-6            | 5M/T         | x                             |
|                    | V43W                       | 6G72-1<br>(3,0)  | -        | Dubbel   | x                               | -                        | MPI                        | V5MT1-6<br>V4AW2-7 | 5M/T<br>4A/T | x<br>x                        |
|                    | V25W<br>V45W               | 6G74-1<br>(3,5)  | -        | Vier     | x                               | -                        | MPI                        | V5M31-5<br>V4AW3-7 | 5M/T<br>4A/T | x<br>x                        |
|                    | V36V<br>V36W               | 4M40<br>(2,8)    | x        | Enkel    | -                               | -                        | Diesel<br>S-RGS            | V5M21-6            | 5M/T         | x                             |

## 1997 modellen voor algemene export

| Voertuig-<br>model | Voertuig<br>model-<br>code | Motor            |          |          |                                 |                          | Brand-<br>stof-<br>systeem | Versnelingsbak     |              |                               |
|--------------------|----------------------------|------------------|----------|----------|---------------------------------|--------------------------|----------------------------|--------------------|--------------|-------------------------------|
|                    |                            | Model<br>(liter) | Balansas | Nokkenas | Hydrau-<br>lische<br>klepstoter | Turbo<br>compres-<br>sor |                            | Model              | Type         | Vierwiel-<br>aandrij-<br>ving |
| Pajero/<br>Montero | V44W                       | 4D56-2<br>(2,5)  | x        | Enkel    | -                               | x                        | Diesel<br>S-RGS            | V5MT1-6<br>V4AW2-7 | 5M/T<br>4A/T | x<br>x                        |
|                    | V46W                       | 4M40<br>(2,8)    | x        | Enkel    | -                               | x                        | Diesel<br>S-RGS            | V5M31-5<br>V4AW3-7 | 5M/T<br>4A/T | x<br>x                        |
| L200               | K02T<br>K12T               | 4G63-8<br>(2,0)  | -        | Enkel    | -                               | -                        | CARB                       | R5M21-1            | 5M/T         | -                             |
|                    | K03T<br>K13T               | 4G54-1<br>(2,6)  | -        | Enkel    | -                               | -                        | CARB                       | R5M21-1            | 5M/T         | -                             |
|                    | K14T                       | 4G56-2<br>(2,5)  | x        | Enkel    | -                               | -                        | Diesel<br>S-RGS            | R5M21-5            | 5M/T         | -                             |
|                    | K15T                       | 4G64-3<br>(2,4)  | x        | Enkel    | x                               | -                        | MPI                        | R5M21-9            | 5M/T         | -                             |
|                    | K24T<br>K34T               | 4D56-2<br>(2,5)  | x        | Enkel    | -                               | -                        | Diesel<br>S-RGS            | V5M21-5            | 5M/T         | x                             |
|                    | K34T                       | 4D56-2<br>(2,5)  | x        | Enkel    | -                               | x                        | Diesel<br>S-RGS            | V5M21-5            | 5M/T         | x                             |
|                    | K32T                       | 4G63-8<br>(2,0)  | -        | Enkel    | -                               | -                        | CARB                       | V5M21-1            | 5M/T         | x                             |
|                    | K35T                       | 4G64-3<br>(2,4)  | x        | Enkel    | x                               | -                        | MPI                        | V5M21-9            | 5M/T         | x                             |
|                    | K62T                       | 4G63-6<br>(2,0)  | x        | Enkel    | -                               | -                        | CARB<br>MPI                | R5M21-5            | 5M/T         | -                             |
|                    | K64T                       | 4D56-3<br>(2,5)  | x        | Enkel    | -                               | -                        | Diesel<br>S-RGS            | R5M21-5            | 5M/T         | -                             |
|                    | K65T                       | 4G64-2<br>(2,4)  | x        | Enkel    | -                               | -                        | MPI                        | R5M21-5<br>R4AW2-6 | 5M/T<br>4A/T | -<br>-                        |
| K72T               | 4G63-6<br>(2,0)            | x                | Enkel    | -        | -                               | CARB<br>MPI              | V5M21-5                    | 5M/T               | x            |                               |

1997 modellen voor algemene export

| Voertuig-<br>model | Voertuig<br>model-<br>code | Motor            |          |          |                                 |                          | Brand-<br>stof-<br>systeem | Versnelingsbak     |              |                               |
|--------------------|----------------------------|------------------|----------|----------|---------------------------------|--------------------------|----------------------------|--------------------|--------------|-------------------------------|
|                    |                            | Model<br>(liter) | Balansas | Nokkenas | Hydrau-<br>lische<br>klepstoter | Turbo<br>compres-<br>sor |                            | Model              | Type         | Vierwiel-<br>aandrij-<br>ving |
| L200               | K74T                       | 4D56-3<br>(2,5)  | ×        | Enkel    | –                               | –                        | Diesel<br>S-RGS            | V5M21-5            | 5M/T         | ×                             |
|                    | K75T                       | 4G64-2<br>(2,4)  | ×        | Enkel    | –                               | –                        | MPI                        | V5M21-5            | 5M/T         | ×                             |
| L300               | P06V                       | 4G93-0<br>(1,8)  | –        | Enkel    | –                               | –                        | CARB                       | R5M21-2            | 5M/T         | –                             |
|                    | P03V<br>P03W<br>P13W       | 4G63-B<br>(2,0)  | ×        | Enkel    | ×                               | –                        | CARB                       | R5M21-2            | 5M/T         | –                             |
|                    | P13V                       | 4G63-6<br>(2,0)  | ×        | Enkel    | ×                               | –                        | MPI                        | R5M21-2            | 5M/T         | –                             |
|                    |                            | 4G63-B<br>(2,0)  | ×        | Enkel    | ×                               | –                        | CARB                       | R5M21-2            | 5M/T         | –                             |
|                    | P15V<br>P15W               | 4D56-2<br>(2,5)  | ×        | Enkel    | –                               | –                        | Diesel<br>S-RGS            | R5M21-2            | 5M/T         | –                             |
|                    | P23W                       | 4G63-B<br>(2,0)  | ×        | Enkel    | ×                               | –                        | CARB                       | V5M21-2            | 5M/T         | ×                             |
| L400               | PA3V<br>PB3V               | 4G63-B<br>(2,0)  | –        | Enkel    | ×                               | –                        | CARB                       | R5M21-7            | 5M/T         | –                             |
|                    | PB4V                       | 4G64-2<br>(2,4)  | ×        | Enkel    | ×                               | –                        | MPI                        | R5M21-7            | 5M/T         | –                             |
|                    | PB5V                       | 4D56-2<br>(2,5)  | ×        | Enkel    | –                               | ×                        | Diesel<br>S-RGS            | R5M31-7            | 5M/T         | –                             |
| Space<br>Gear      | PA3W                       | 4G63-B<br>(2,0)  | ×        | Enkel    | ×                               | –                        | CARB                       | R5M21-7<br>R4AW2-5 | 5M/T<br>4A/T | –                             |
|                    |                            | 4G63-6<br>(2,0)  | ×        | Enkel    | ×                               | –                        | MPI                        | R5M21-7            | 5M/T         | –                             |
|                    | PC3W                       | 4G63-B<br>(2,0)  | ×        | Enkel    | ×                               | –                        | CARB                       | R5M21-7            | 5M/T         | –                             |
|                    | PA4W                       | 4G64-2<br>(2,4)  | ×        | Enkel    | ×                               | –                        | MPI                        | R5M21-7<br>R4AW2-5 | 5M/T<br>4A/T | –<br>–                        |

## 1997 modellen voor algemene export

| Voertuig-<br>model | Voertuig<br>model-<br>code | Motor            |          |          |                                 |                          | Brand-<br>stof-<br>systeem | Versnelingsbak     |              |                               |
|--------------------|----------------------------|------------------|----------|----------|---------------------------------|--------------------------|----------------------------|--------------------|--------------|-------------------------------|
|                    |                            | Model<br>(liter) | Balansas | Nokkenas | Hydrau-<br>lische<br>klepstoter | Turbo<br>compres-<br>sor |                            | Model              | Type         | Vierwiel-<br>aandrij-<br>ving |
| Space<br>Gear      | PA5W                       | 4D56-2<br>(2,5)  | ×        | Enkel    | –                               | ×                        | Diesel<br>S-RGS            | R5M31-7            | 5M/T         | –                             |
|                    | PD3W                       | 4G63-B<br>(2,0)  | ×        | Enkel    | ×                               | –                        | MPI                        | V5M21-7            | 5M/T         | ×                             |
|                    | PD4W                       | 4G64-2<br>(2,4)  | ×        | Enkel    | ×                               | –                        | MPI                        | V5M21-7            | 5M/T         | ×                             |
|                    | PD5W                       | 4D56-2<br>(2,5)  | ×        | Enkel    | –                               | ×                        | Diesel<br>S-RGS            | V5M31-7            | 5M/T         | ×                             |
| SIGMA              | F36A                       | 6G72-5<br>(3,0)  | –        | Dubbel   | ×                               | –                        | MPI                        | F5M51-1<br>F4A51-2 | 5M/T<br>4A/T | –<br>–                        |
| 3000GT             | Z16A                       | 6G72-4<br>(3,0)  | –        | Vier     | ×                               | ×                        | MPI                        | W5MG1-2            | 6M/T         | ×                             |
| Eclipse            | D32A                       | 4G63-7<br>(2,0)  | ×        | Dubbel   | ×                               | –                        | MPI                        | F5M31-2            | 5M/T         | –                             |

1997 modellen voor Australië

| Voertuig-model     | Voertuig-model-code | Motor           |          |          |                         |                  | Brandstof-systeem | Versnellingsbak    |              |                      |
|--------------------|---------------------|-----------------|----------|----------|-------------------------|------------------|-------------------|--------------------|--------------|----------------------|
|                    |                     | Model (liter)   | Balansas | Nokkenas | Hydraulische klepstoter | Turbo compressor |                   | Model              | Type         | Vierwiel-aandrijving |
| Mirage             | CJ2A                | 4G15-3<br>(1,5) | -        | Enkel    | -                       | -                | MPI               | F5M41-1<br>F4A41-1 | 5M/T<br>4A/T | -<br>-               |
|                    | CJ5A                | 4G93-3<br>(1,8) | -        | Enkel    | -                       | -                | MPI               | F5M41-1<br>F4A41-1 | 5M/T<br>4A/T | -<br>-               |
| Lancer Wagon       | CB5W                | 4G93-0<br>(1,8) | -        | Enkel    | -                       | -                | MPI               | F5M22-2<br>F4A22-2 | 5M/T<br>4A/T | -<br>-               |
| Lancer             | CK2A                | 4G15-3<br>(1,5) | -        | Enkel    | -                       | -                | MPI               | F5M41-1<br>F4A41-1 | 5M/T<br>4A/T | -<br>-               |
|                    | CK5A                | 4G93-3<br>(1,8) | -        | Enkel    | -                       | -                | MPI               | F5M41-1<br>F4A41-1 | 5M/T<br>4A/T | -<br>-               |
| Space Wagon        | N34W                | 4G64-6<br>(2,4) | x        | Enkel    | x                       | -                | MPI               | F5M31-2<br>F4A23-2 | 5M/T<br>4A/T | -<br>-               |
| Pajero/<br>Montero | V23W                | 6G72-1<br>(3,0) | -        | Dubbel   | x                       | -                | MPI               | V5MT1-6<br>V4AW2-7 | 5M/T<br>4A/T | x<br>x               |
|                    | V43W                | 6G72-1<br>(3,0) | -        | Dubbel   | x                       | -                | MPI               | V5MT1-6<br>V4AW2-7 | 5M/T<br>4A/T | x<br>x               |
|                    | V36W                | 4M40<br>(2,8)   | x        | Enkel    | -                       | x                | Diesel<br>S-RGS   | V5M21-6            | 5M/T         | x                    |
|                    | V46W                | 4M40<br>(2,8)   | x        | Enkel    | -                       | x                | Diesel<br>S-RGS   | V5M31-5            | 5M/T         | x                    |
|                    | V45W                | 6G74-1<br>(3,5) | -        | Vier     | x                       | -                | MPI               | V4AW3-7            | 4A/T         | x                    |
| L200               | K65T                | 4G64-2<br>(2,4) | x        | Enkel    | x                       | -                | MPI               | R5M21-5<br>R4AW2-6 | 5M/T<br>4A/T | -<br>-               |
|                    | K67T                | 4M40<br>(2,8)   | x        | Enkel    | -                       | -                | Diesel<br>S-RGS   | R5M21-6            | 5M/T         | -                    |
|                    | K76T                | 6G72-8<br>(3,0) | -        | Dubbel   | x                       | -                | MPI               | V5MT1-4<br>V4AW3-6 | 5M/T<br>4A/T | x<br>x               |
|                    | K77T                | 4M40<br>(2,8)   | x        | Enkel    | -                       | -                | Diesel<br>S-RGS   | V5M21-6            | 5M/T         | x                    |

## 1997 modellen voor Australië

| Voertuig-<br>model | Voertuig<br>model-<br>code | Motor            |          |          |                                 |                          | Brand-<br>stof-<br>systeem | Versnelingsbak     |              |                               |
|--------------------|----------------------------|------------------|----------|----------|---------------------------------|--------------------------|----------------------------|--------------------|--------------|-------------------------------|
|                    |                            | Model<br>(liter) | Balansas | Nokkenas | Hydrau-<br>lische<br>klepstoter | Turbo<br>compres-<br>sor |                            | Model              | Type         | Vierwiel-<br>aandrij-<br>ving |
| L300               | P03V                       | 4G63-9<br>(2,0)  | x        | Enkel    | x                               | –                        | CARB                       | R5M21-2<br>R4AW2-2 | 5M/T<br>4A/T | –<br>–                        |
|                    |                            | 4G63-A<br>(2,0)  | x        | Enkel    | x                               | –                        | CARB                       | R5M21-2<br>R4AW2-8 | 5M/T<br>4A/T | –<br>–                        |
|                    | P03W                       | 4G63-9<br>(2,0)  | x        | Enkel    | x                               | –                        | CARB                       | R5M21-2<br>R4AW2-2 | 5M/T<br>4A/T | –<br>–                        |
|                    | P05V<br>P15V               | 4D56-2<br>(2,5)  | x        | Enkel    | –                               | –                        | Diesel<br>S-RGS            | R5M21-2            | 5M/T         | –                             |
|                    | P14V                       | 4G64-2<br>(2,4)  | x        | Enkel    | x                               | –                        | MPI                        | R5M21-2<br>R4AW2-8 | 5M/T<br>4A/T | –<br>–                        |
|                    | P24V                       | 4G64-2<br>(2,4)  | x        | Enkel    | x                               | –                        | MPI                        | V5M21-2            | 5M/T         | x                             |
| L400               | PB4V<br>PA4W               | 4G64-2<br>(2,4)  | x        | Enkel    | x                               | –                        | MPI                        | R5M21-7<br>R4AW2-5 | 5M/T<br>4A/T | –<br>–                        |
|                    | PA3W                       | 4G63-A<br>(2,0)  | x        | Enkel    | x                               | –                        | CARB                       | R5M21-7<br>R4AW2-5 | 5M/T<br>4A/T | –<br>–                        |
|                    | PB6W                       | 6G72-8<br>(3,0)  | –        | Dubbel   | x                               | –                        | MPI                        | R4AW3-5            | 4A/T         | –                             |
| SIGMA              | F36A                       | 6G72-5<br>(3,0)  | –        | Dubbel   | x                               | –                        | MPI                        | F5M51-1<br>F4A51-2 | 5M/T<br>4A/T | –<br>–                        |
| 3000GT             | Z16A                       | 6G72-4<br>(3,0)  | –        | Vier     | x                               | x                        | MPI                        | W5MG1-2            | 6M/T         | x                             |

## 1998 modellen voor Europa

| Voertuig-<br>model | Voertuig<br>model-<br>code | Motor            |          |          |                                 |                          | Brand-<br>stof-<br>systeem | Versnelingsbak        |              |                               |
|--------------------|----------------------------|------------------|----------|----------|---------------------------------|--------------------------|----------------------------|-----------------------|--------------|-------------------------------|
|                    |                            | Model<br>(liter) | Balansas | Nokkenas | Hydrau-<br>lische<br>klepstoter | Turbo<br>compres-<br>sor |                            | Model                 | Type         | Vierwiel-<br>aandrij-<br>ving |
| Colt               | CJ1A                       | 4G13-3<br>(1,3)  | -        | Enkel    | -                               | -                        | MPI                        | F5M41-1<br>F4A41-1    | 5M/T<br>4A/T | -<br>-                        |
|                    |                            | 4G92-3<br>(1,6)  | -        | Enkel    | -                               | -                        | MPI                        | F5M41-1<br>F4A41-1    | 5M/T<br>4A/T | -<br>-                        |
|                    | 4G92-8<br>(1,6)            | -                | Enkel    | -        | -                               | MPI                      | F5M41-1                    | 5M/T                  | -            |                               |
| Lancer             | CB4W                       | 4G92-0<br>(1,6)  | -        | Enkel    | -                               | -                        | MPI                        | F5M22-2<br>F4A22-2    | 5M/T<br>4A/T | -<br>-                        |
|                    | CD4W                       | 4G92-0<br>(1,6)  | -        | Enkel    | -                               | -                        | MPI                        | W5M31-2               | 5M/T         | x                             |
|                    | CK1A                       | 4G13-3<br>(1,3)  | -        | Enkel    | -                               | -                        | MPI                        | F5M41-1<br>F4A41-1    | 5M/T<br>4A/T | -<br>-                        |
| Carisma            | DA1A                       | 4G92-2<br>(1,6)  | -        | Enkel    | -                               | -                        | MPI                        | F5MR1(JB3)<br>F4A41-1 | 5M/T<br>4A/T | -<br>-                        |
|                    | DA2A                       | 4G93-2<br>(1,8)  | -        | Enkel    | -                               | -                        | MPI                        | F5MR1(JB3)<br>F4A42-1 | 5M/T<br>4A/T | -<br>-                        |
|                    |                            | 4G93-G<br>(1,8)  | -        | Dubbel   | x                               | -                        | GDI                        | F5M42-1<br>F4A42-1    | 5M/T<br>4A/T | -                             |
|                    | DA4A                       | F8QT<br>(1,8)    | -        | Enkel    | -                               | -                        | Diesel<br>S-QGS            | F5MR3<br>(JC5)        | 5M/T         | -                             |
| Space<br>Runner    | N11W                       | 4G93-0<br>(1,8)  | -        | Enkel    | -                               | -                        | MPI                        | F5M22-1<br>F4A22-2    | 5M/T<br>4A/T | -<br>-                        |
|                    | N18W                       | 4D68-0<br>(2,0)  | x        | Enkel    | -                               | x                        | Diesel<br>S-RGS            | F5M31-1               | 5M/T         | -                             |
|                    | N21W                       | 4G93-0<br>(1,8)  | -        | Enkel    | -                               | -                        | MPI                        | W5M31-2               | 5M/T         | x                             |
| Space<br>Wagon     | N33W                       | 4G63-6<br>(2,0)  | x        | Enkel    | x                               | -                        | MPI                        | F5M22-1<br>F4A22-2    | 5M/T<br>4A/T | -<br>-                        |
|                    |                            | 4D68-0<br>(2,0)  | x        | Enkel    | -                               | x                        | Diesel<br>S-RGS            | F5M31-1               | 5M/T         | -                             |
|                    | N43W                       | 4G63-6<br>(2,0)  | x        | Enkel    | -                               | x                        | MPI                        | W5M31-2<br>W4A32-1    | 5M/T<br>4A/T | x<br>x                        |



## 1998 modellen voor Europa

| Voertuig-<br>model | Voertuig<br>model-<br>code | Motor            |          |          |                                 |                          | Brand-<br>stof-<br>systeem | Versnelingsbak                |                      |                               |
|--------------------|----------------------------|------------------|----------|----------|---------------------------------|--------------------------|----------------------------|-------------------------------|----------------------|-------------------------------|
|                    |                            | Model<br>(liter) | Balansas | Nokkenas | Hydrau-<br>lische<br>klepstoter | Turbo<br>compres-<br>sor |                            | Model                         | Type                 | Vierwiel-<br>aandrij-<br>ving |
| Galant             | EA2A<br>EA2W               | 4G63-6<br>(2,0)  | ×        | Enkel    | ×                               | –                        | MPI                        | F5M42-2<br>F4A42-2            | 5M/T<br>4A/T         | –<br>–                        |
|                    | EA5A<br>EA5W               | 6A13-4<br>(2,5)  | –        | Dubbel   | ×                               | –                        | MPI                        | F5M42-2<br>F4A42-2            | 5M/T<br>4A/T         | –<br>–                        |
|                    | EA6A<br>EA6W               | 4D68-4<br>(2,0)  | ×        | Enkel    | –                               | ×                        | Diesel<br>S-RGS            | F5M42-2                       | 5M/T                 | –                             |
| Pajero/<br>Montero | V23C<br>V23W               | 6G72-8<br>(3,0)  | –        | Dubbel   | ×                               | –                        | MPI                        | V5MT1-6<br>V4AW3-B            | 5M/T<br>4A/T         | ×                             |
|                    | V24C<br>V24W<br>V44W       | 4D56-2<br>(2,5)  | ×        | Enkel    | –                               | ×                        | Diesel<br>S-RGS            | V5MT1-6                       | 5M/T                 | ×                             |
|                    | V25W<br>V45W               | 6G74-1<br>(3,5)  | –        | Vier     | ×                               | –                        | MPI                        | V5M31-5<br>V4AW3-B            | 5M/T<br>4A/T         | ×                             |
|                    | V26W                       | 4M40<br>(2,8)    | ×        | Enkel    | –                               | ×                        | Diesel<br>S-RGS            | V5M31-5                       | 5M/T                 | ×                             |
|                    | V43W                       | 6G72-8<br>(3,0)  | –        | Dubbel   | ×                               | –                        | MPI                        | V5MT1-6<br>V4AW3-B<br>V4AW3-7 | 5M/T<br>4A/T<br>4A/T | ×                             |
|                    | V46W                       | 4M40<br>(2,8)    | ×        | Enkel    | –                               | ×                        | Diesel<br>S-RGS            | V5M31-5<br>V4AW3-B            | 5M/T<br>4A/T         | ×                             |
|                    | V46W                       | 4M40<br>(2,8)    | ×        | Enkel    | –                               | ×                        | Diesel<br>S-RGS            | V5M31-5<br>V4AW3-B            | 5M/T<br>4A/T         | ×                             |
| L200               | K62T                       | 4G63-6<br>(2,0)  | ×        | Enkel    | ×                               | –                        | MPI                        | R5M21-5<br>R4AW2-6            | 5M/T<br>4A/T         | –<br>–                        |
|                    | K64T                       | 4D56-3<br>(2,5)  | ×        | Enkel    | –                               | –                        | Diesel<br>S-RGS            | R5M21-5                       | 5M/T                 | –                             |
|                    | K74T                       | 4D56-3<br>(2,5)  | ×        | Enkel    | –                               | ×                        | Diesel<br>S-RGS            | V5MT1-4<br>V4AW2-6            | 5M/T<br>4A/T         | ×                             |
|                    | K75T                       | 4G64-2<br>(2,4)  | ×        | Enkel    | ×                               | –                        | MPI                        | V5M21-9                       | 5M/T                 | ×                             |

1998 modellen voor Europa

| Voertuig-<br>model | Voertuig<br>model-<br>code | Motor            |          |          |                                 |                          | Brand-<br>stof-<br>systeem | Versnelingsbak                |                      |                               |
|--------------------|----------------------------|------------------|----------|----------|---------------------------------|--------------------------|----------------------------|-------------------------------|----------------------|-------------------------------|
|                    |                            | Model<br>(liter) | Balansas | Nokkenas | Hydrau-<br>lische<br>klepstoter | Turbo<br>compres-<br>sor |                            | Model                         | Type                 | Vierwiel-<br>aandrij-<br>ving |
| L300               | P03V<br>P13V               | 4G63-6<br>(2,0)  | x        | Enkel    | x                               | -                        | MPI                        | R5M21-2                       | 5M/T                 | -                             |
|                    | P05V<br>P15V               | 4D56-2<br>(2,5)  | x        | Enkel    | -                               | x                        | Diesel<br>S-RGS            | R5M21-2                       | 5M/T                 | -                             |
|                    | P13T                       | 4G63-6<br>(2,0)  | x        | Enkel    | x                               | -                        | MPI                        | R5M21-2                       | 5M/T                 | -                             |
|                    | P15T                       | 4D56-2<br>(2,5)  | x        | Enkel    | -                               | x                        | Diesel<br>S-RGS            | R5M21-2                       | 5M/T                 | -                             |
|                    | P45V                       | 4D56-2<br>(2,5)  | x        | Enkel    | -                               | x                        | Diesel<br>S-RGS            | V5M21-2                       | 5M/T                 | x                             |
| L400               | PA3V<br>PB3V               | 4G63-6<br>(2,0)  | x        | Enkel    | x                               | -                        | MPI                        | R5M21-7                       | 5M/T                 | -                             |
|                    | PA5V<br>PB5V               | 4D56-2<br>(2,5)  | x        | Enkel    | -                               | x                        | Diesel<br>S-RGS            | R5M21-7                       | 5M/T                 | -                             |
|                    | PD4V                       | 4G64-2<br>(2,4)  | x        | Enkel    | x                               | -                        | MPI                        | V5M21-7                       | 5M/T                 | x                             |
|                    | PD5V                       | 4D56-2<br>(2,5)  | x        | Enkel    | -                               | x                        | Diesel<br>S-RGS            | V5M21-7                       | 5M/T                 | x                             |
| Space<br>Gear      | PA3W                       | 4G63-6<br>(2,0)  | x        | Enkel    | x                               | -                        | MPI                        | R5M21-7<br>R4AW2-5            | 5M/T<br>4A/T         | -<br>-                        |
|                    | PA4W                       | 4G64-2<br>(2,4)  | x        | Enkel    | x                               | -                        | MPI                        | R5M21-7<br>R4AW2-5<br>R4AW2-8 | 5M/T<br>4A/T<br>4A/T | -<br>-<br>-                   |
|                    | PA5W                       | 4D56-2<br>(2,5)  | x        | Enkel    | -                               | x                        | Diesel<br>S-RGS            | R5M31-7                       | 5M/T                 | -                             |
|                    | PD4W                       | 4G64-2<br>(2,4)  | x        | Enkel    | x                               | -                        | MPI                        | V5M21-7                       | 5M/T                 | x                             |
|                    | PD5W                       | 4D56-2<br>(2,5)  | x        | Enkel    | -                               | x                        | Diesel<br>S-RGS            | V5M31-7                       | 5M/T                 | x                             |
| 3000GT             | Z16A                       | 6G72-4<br>(3,0)  | -        | Vier     | x                               | x                        | MPI                        | W6MG1-0                       | 6M/T                 | x                             |
| Eclipse            | D32T                       | 4G63-7<br>(2,0)  | x        | Dubbel   | x                               | -                        | MPI                        | F5M31-2                       | 5M/T                 | -                             |

## 1998 modellen voor algemene export

| Voertuig-<br>model | Voertuig<br>model-<br>code | Motor            |                 |          |                                 |                          | Brand-<br>stof-<br>systeem | Versnelingsbak |         |                               |   |
|--------------------|----------------------------|------------------|-----------------|----------|---------------------------------|--------------------------|----------------------------|----------------|---------|-------------------------------|---|
|                    |                            | Model<br>(liter) | Balansas        | Nokkenas | Hydrau-<br>lische<br>klepstoter | Turbo<br>compres-<br>sor |                            | Model          | Type    | Vierwiel-<br>aandrij-<br>ving |   |
| Colt               | CJ1A                       | 4G13-3<br>(1,3)  | -               | Enkel    | -                               | -                        | CARB                       | F5M41-1        | 5M/T    | -                             |   |
|                    |                            | 4G13-5<br>(1,3)  | -               | Enkel    | -                               | -                        | CARB                       | F5M41-1        | 5M/T    | -                             |   |
|                    | CJ2A                       | 4G15-5<br>(1,5)  | -               | Enkel    | -                               | -                        | CARB                       | F5M41-1        | 5M/T    | -                             |   |
|                    |                            |                  |                 |          |                                 |                          |                            | F4M41-1        | 4A/T    | -                             |   |
| CJ4A               | 4G92-3<br>(1,6)            | -                | Enkel           | -        | -                               | MPI                      | F5M41-1                    | 5M/T           | -       |                               |   |
|                    |                            |                  |                 |          |                                 |                          | F4A41-1                    | 4A/T           | -       |                               |   |
| Lancer             | CB1W                       | 4G13-2<br>(1,3)  | -               | Enkel    | -                               | -                        | CARB                       | F5M21-1        | 5M/T    | -                             |   |
|                    |                            |                  |                 |          |                                 |                          |                            | F3A21-2        | 3A/T    | -                             |   |
|                    | CB2W                       | 4G15-2<br>(1,5)  | -               | Enkel    | -                               | -                        | CARB                       | F5M21-1        | 5M/T    | -                             |   |
|                    |                            |                  |                 |          |                                 |                          |                            | F3A21-2        | 3A/T    | -                             |   |
|                    | CB4W                       | 4G92-0<br>(1,6)  | -               | Enkel    | -                               | -                        | MPI                        | F5M22-2        | 5M/T    | -                             |   |
|                    |                            |                  |                 |          |                                 |                          |                            | F4A22-2        | 4A/T    | -                             |   |
|                    | CK1A                       | 4G13-5<br>(1,3)  | -               | Enkel    | -                               | -                        | CARB                       | F5M41-1        | 5M/T    | -                             |   |
|                    |                            |                  |                 |          |                                 |                          |                            | F4A41-1        | 4A/T    | -                             |   |
|                    |                            |                  | 4G13-3<br>(1,3) | -        | Enkel                           | -                        | -                          | MPI            | F5M41-1 | 5M/T                          | - |
|                    |                            |                  |                 |          |                                 |                          |                            |                | F4A41-1 | 4A/T                          | - |
| CK2A               | 4G15-5<br>(1,5)            | -                | Enkel           | -        | -                               | CARB                     | F5M41-1                    | 5M/T           | -       |                               |   |
|                    |                            |                  |                 |          |                                 |                          | F4A41-1                    | 4A/T           | -       |                               |   |
|                    |                            | 4G15-4<br>(1,5)  | -               | Enkel    | -                               | -                        | MPI                        | F5M41-1        | 5M/T    | -                             |   |
|                    |                            |                  |                 |          |                                 |                          |                            | F4A41-1        | 4A/T    | -                             |   |
| CK4A               | 4G92-3<br>(1,6)            | -                | Enkel           | -        | -                               | MPI                      | F5M41-1                    | 5M/T           | -       |                               |   |
|                    |                            |                  |                 |          |                                 |                          | F4A41-1                    | 4A/T           | -       |                               |   |
|                    |                            | 4G92-7<br>(1,6)  | -               | Dubbel   | -                               | -                        | MPI                        | F5M42-1        | 5M/T    | -                             |   |
|                    |                            |                  |                 |          |                                 |                          |                            | F4A42-1        | 4A/T    | -                             |   |
| Space<br>Wagon     | N31W                       | 4G93-0<br>(1,8)  | -               | Enkel    | -                               | -                        | CARB                       | F5M22-1        | 5M/T    | -                             |   |
|                    |                            |                  |                 |          |                                 |                          |                            | F4A22-2        | 4A/T    | -                             |   |
|                    | N33W                       | 4G63-6<br>(2,0)  | ×               | Enkel    | -                               | -                        | MPI                        | F5M22-1        | 5M/T    | -                             |   |
|                    |                            |                  |                 |          |                                 |                          |                            | F4A22-2        | 4A/T    | -                             |   |

## 1998 modellen voor algemene export

| Voertuig-<br>model | Voertuig<br>model-<br>code | Motor            |          |          |                                 |                          | Brand-<br>stof-<br>systeem | Versnelingsbak     |              |                               |
|--------------------|----------------------------|------------------|----------|----------|---------------------------------|--------------------------|----------------------------|--------------------|--------------|-------------------------------|
|                    |                            | Model<br>(liter) | Balansas | Nokkenas | Hydrau-<br>lische<br>klepstoter | Turbo<br>compres-<br>sor |                            | Model              | Type         | Vierwiel-<br>aandrij-<br>ving |
| Galant             | EA1A                       | 4G93-9<br>(1,8)  | -        | Enkel    | -                               | -                        | CARB                       | F5M42-1<br>F4A42-1 | 5M/T<br>4A/T | -<br>-                        |
|                    |                            | 4G63-E<br>(2,0)  | x        | Enkel    | x                               | -                        | CARB                       | F5M42-1<br>F4A42-1 | 5M/T<br>4A/T | -<br>-                        |
|                    |                            | 4G63-6<br>(2,0)  | x        | Enkel    | x                               | -                        | CARB                       | F5M42-1<br>F4A42-1 | 5M/T<br>4A/T | -<br>-                        |
|                    | EA4A                       | 6A12-2<br>(2,0)  | -        | Dubbel   | x                               | -                        | MPI                        | F5M42-2<br>F4A42-1 | 5M/T<br>4A/T | -<br>-                        |
|                    | EA5A                       | 6A13-4<br>(2,5)  | -        | Dubbel   | x                               | -                        | MPI                        | F5M42-2<br>F4A42-2 | 5M/T<br>4A/T | -<br>-                        |
|                    | EA6A                       | 4D68-2<br>(2,0)  | x        | Enkel    | -                               | x                        | Diesel<br>S-RGS            | F5M42-2            | 5M/T         | -                             |
| Pajero/<br>Montero | V11V<br>V31V               | 4G64-6<br>(2,4)  | x        | Enkel    | x                               | -                        | CARB                       | V5M21-6            | 5M/T         | x                             |
|                    |                            | 4G64-2<br>(2,4)  | x        | Enkel    | x                               | -                        | MPI                        | V5M21-6            | 5M/T         | x                             |
|                    | V13V<br>V33V<br>V33W       | 6G72-1<br>(3,0)  | -        | Dubbel   | x                               | -                        | MPI                        | V5MT1-6            | 5M/T         | x                             |
|                    |                            | 4D56-2<br>(2,5)  | x        | Enkel    | -                               | x                        | Diesel<br>S-RGS            | V5MT1-6            | 5M/T         | x                             |
|                    | V14V<br>V14C<br>V34V       | 4D56-2<br>(2,5)  | x        | Enkel    | -                               | -                        | Diesel<br>S-RGS            | V5M21-6            | 5M/T         | x                             |
|                    |                            | 6G72-8<br>(3,0)  | -        | Dubbel   | x                               | x                        | MPI                        | V5MT1-6            | 5M/T         | x                             |
|                    |                            | 6G72-1<br>(3,0)  | -        | Dubbel   | x                               | -                        | MPI                        | V5MT1-6<br>V4AW2-7 | 5M/T<br>4A/T | x<br>x                        |
|                    | V25W<br>V45W               | 6G74-1<br>(3,5)  | -        | Vier     | x                               | -                        | MPI                        | V5M31-5<br>V4AW3-B | 5M/T<br>4A/T | x<br>x                        |
| V26W               |                            | 4M40<br>(3,5)    | x        | Enkel    | -                               | -                        | Diesel<br>S-RGS            | V5M31-5            | 5M/T         | x                             |

## 1998 modellen voor algemene export

| Voertuig-<br>model | Voertuig<br>model-<br>code | Motor            |          |          |                                 |                          | Brand-<br>stof-<br>systeem | Versnelingsbak     |              |                               |
|--------------------|----------------------------|------------------|----------|----------|---------------------------------|--------------------------|----------------------------|--------------------|--------------|-------------------------------|
|                    |                            | Model<br>(liter) | Balansas | Nokkenas | Hydrau-<br>lische<br>klepstoter | Turbo<br>compres-<br>sor |                            | Model              | Type         | Vierwiel-<br>aandrij-<br>ving |
| Pajero/<br>Montero | V31W                       | 4G64-2<br>(2,4)  | x        | Enkel    | x                               | –                        | MPI                        | V5M21-6<br>V4AW2-A | 5M/T<br>4A/T | x<br>x                        |
|                    | V33W                       | 6G72-1<br>(3,0)  | –        | Dubbel   | x                               | –                        | MPI                        | V5M21-6            | 5M/T         | x                             |
|                    | V36V<br>V36W               | 4M40<br>(2,8)    | x        | Enkel    | –                               | –                        | Diesel<br>S-RGS            | V5M21-6            | 5M/T         | x                             |
|                    | V43W                       | 6G72-1<br>(3,0)  | –        | Dubbel   | x                               | –                        | MPI                        | V5M21-6<br>V4AW2-7 | 5M/T<br>4A/T | x<br>x                        |
|                    |                            | 6G72-8<br>(3,0)  | –        | Dubbel   | x                               | –                        | MPI                        | V5M21-6<br>V4AW3-7 | 5M/T<br>4A/T | x<br>x                        |
|                    | V44W                       | 4D56-2<br>(2,5)  | x        | Enkel    | –                               | x                        | Diesel<br>S-RGS            | V4AW3-7            | 4A/T         | x                             |
|                    | V46W                       | 4M40<br>(2,8)    | x        | Enkel    | –                               | x                        | Diesel<br>S-RGS            | V5M31-5<br>V4AW3-B | 5M/T<br>4A/T | x<br>x                        |
| L300               | P03V<br>P03W<br>P13W       | 4G63-B<br>(2,0)  | x        | Enkel    | x                               | –                        | CARB                       | R5M21-2            | 5M/T         | –                             |
|                    | P03W                       | 4G63-B<br>(2,0)  | x        | Enkel    | x                               | –                        | CARB                       | R4AW2-8            | 4A/T         | –                             |
|                    | P06V<br>P16V               | 4G92-0<br>(1,6)  | –        | Enkel    | –                               | –                        | CARB                       | R5M21-2            | 5M/T         | –                             |
|                    | P13V                       | 4G63-6<br>(2,0)  | x        | Enkel    | x                               | –                        | MPI                        | R5M21-2            | 5M/T         | –                             |
|                    |                            | 4G63-B<br>(2,0)  | x        | Enkel    | x                               | –                        | CARB                       | R5M21-2            | 5M/T         | –                             |
|                    | P15V<br>P15W               | 4D56-2<br>(2,5)  | x        | Enkel    | –                               | –                        | Diesel<br>S-RGS            | R5M21-2            | 5M/T         | –                             |
|                    | P23W                       | 4G63-B<br>(2,0)  | x        | Enkel    | x                               | –                        | CARB                       | V5M21-2            | 5M/T         | x                             |
| L400               | PB3V                       | 4G63-B<br>(2,0)  | –        | Enkel    | x                               | –                        | CARB                       | R5M21-7            | 5M/T         | –                             |

## 1998 modellen voor algemene export

| Voertuig-<br>model | Voertuig<br>model-<br>code | Motor            |          |          |                                 |                          | Brand-<br>stof-<br>systeem | Versnelingsbak     |              |                               |
|--------------------|----------------------------|------------------|----------|----------|---------------------------------|--------------------------|----------------------------|--------------------|--------------|-------------------------------|
|                    |                            | Model<br>(liter) | Balansas | Nokkenas | Hydrau-<br>lische<br>klepstoter | Turbo<br>compres-<br>sor |                            | Model              | Type         | Vierwiel-<br>aandrij-<br>ving |
| Space<br>Gear      | PA3W                       | 4G63-B<br>(2,0)  | ×        | Enkel    | ×                               | –                        | CARB                       | R4AW2-5            | 4A/T         | –                             |
|                    | PA4W                       | 4G64-2<br>(2,4)  | ×        | Enkel    | ×                               | –                        | MPI                        | R5M21-7<br>R4AW2-5 | 5M/T<br>4A/T | –<br>–                        |
|                    | PA5W<br>PC5W               | 4D56-2<br>(2,5)  | ×        | Enkel    | –                               | ×                        | Diesel<br>S-RGS            | R5M21-7            | 5M/T         | –                             |
|                    | PC3W                       | 4G63-B<br>(2,0)  | ×        | Enkel    | ×                               | –                        | CARB                       | R5M21-7            | 5M/T         | –                             |
|                    | PD3W                       | 4G63-B<br>(2,0)  | ×        | Enkel    | ×                               | –                        | CARB                       | V5M21-7            | 5M/T         | ×                             |
|                    | PD4W                       | 4G64-2<br>(2,4)  | ×        | Enkel    | ×                               | –                        | MPI                        | V5M21-7            | 5M/T         | ×                             |
|                    | PD5W                       | 4D56-2<br>(2,5)  | ×        | Enkel    | –                               | ×                        | Diesel<br>S-RGS            | V5M21-7            | 5M/T         | ×                             |
| Sigma              | F36A                       | 6G72-5<br>(3,0)  | –        | Dubbel   | ×                               | –                        | MPI                        | F5M51-1<br>F4A51-2 | 5M/T<br>4A/T | –<br>–                        |
| 3000GT             | Z16A                       | 6G72-4<br>(3,0)  | –        | Vier     | ×                               | ×                        | MPI                        | W5MG1-2            | 5M/T         | ×                             |

## 1998 modellen voor Australië

| Voertuig-<br>model | Voertuig<br>model-<br>code | Motor            |          |          |                                 |                          | Brand-<br>stof-<br>systeem | Versnelingsbak     |               |                               |       |   |   |                 |         |                 |   |
|--------------------|----------------------------|------------------|----------|----------|---------------------------------|--------------------------|----------------------------|--------------------|---------------|-------------------------------|-------|---|---|-----------------|---------|-----------------|---|
|                    |                            | Model<br>(liter) | Balansas | Nokkenas | Hydrau-<br>lische<br>klepstoter | Turbo<br>compres-<br>sor |                            | Model              | Type          | Vierwiel-<br>aandrij-<br>ving |       |   |   |                 |         |                 |   |
| Space<br>Wagon     | N34W                       | 4G64-2<br>(2,4)  | x        | Enkel    | x                               | -                        | MPI                        | F5M31-2            | 5M/T          | -                             |       |   |   |                 |         |                 |   |
|                    |                            |                  |          |          |                                 |                          |                            | F4A23-2            | 4A/T          | -                             |       |   |   |                 |         |                 |   |
| Pajero/<br>Montero | V25W<br>V45W               | 6G74-8<br>(3,5)  | -        | Vier     | x                               | -                        | MPI                        | V5M31-5<br>V4AW3-B | 5M/T<br>4A/T  | x<br>x                        |       |   |   |                 |         |                 |   |
|                    | V46W                       | 4M40<br>(2,8)    | x        | Enkel    | -                               | x                        | Diesel<br>S-RGS            | V5M31-5            | 5M/T          | x                             |       |   |   |                 |         |                 |   |
| L200               | K65T                       | 4G64-2<br>(2,4)  | x        | Enkel    | x                               | -                        | MPI                        | R5M21-5            | 5M/T          | -                             |       |   |   |                 |         |                 |   |
|                    |                            |                  |          |          |                                 |                          |                            | R4AW2-6            | 4A/T          | -                             |       |   |   |                 |         |                 |   |
|                    |                            |                  |          |          |                                 |                          |                            | K67T               | 4M40<br>(2,8) | x                             | Enkel | - | - | Diesel<br>S-RGS | R5M21-5 | 5M/T            | - |
|                    |                            |                  |          |          |                                 |                          |                            |                    |               |                               |       |   |   |                 | K76T    | 6G72-8<br>(3,0) | - |
| V4AW3-6            | 4A/T                       | x                |          |          |                                 |                          |                            |                    |               |                               |       |   |   |                 |         |                 |   |
| K77T               | 4M40<br>(2,8)              | x                | Enkel    | -        | -                               | Diesel<br>S-RGS          | V5M21-9                    | 5M/T               | x             |                               |       |   |   |                 |         |                 |   |
|                    |                            |                  |          |          |                                 |                          |                            |                    |               |                               |       |   |   |                 |         |                 |   |
| Challenger         | K96T                       | 6G72-8<br>(3,0)  | -        | Dubbel   | x                               | -                        | MPI                        | V5MT1-4<br>V4AW3-6 | 5M/T<br>4A/T  | x<br>x                        |       |   |   |                 |         |                 |   |
| L300               | P03V                       | 4G63-A<br>(2,0)  | x        | Enkel    | x                               | -                        | CARB                       | R5M21-2<br>R4AW2-8 | 5M/T<br>4A/T  | -<br>-                        |       |   |   |                 |         |                 |   |
|                    | P03W                       | 4G63-6<br>(2,0)  | x        | Enkel    | x                               | -                        | MPI                        | R5M21-2<br>R4AW2-8 | 5M/T<br>4A/T  | -<br>-                        |       |   |   |                 |         |                 |   |
|                    | P05V<br>P15V               | 4D56-2<br>(2,5)  | x        | Enkel    | -                               | -                        | Diesel<br>S-RGS            | R5M21-2            | 5M/T          | -                             |       |   |   |                 |         |                 |   |
|                    | P14V                       | 4G64-2<br>(2,4)  | x        | Enkel    | x                               | -                        | MPI                        | R5M21-2<br>R4AW2-8 | 5M/T<br>4A/T  | -<br>-                        |       |   |   |                 |         |                 |   |
|                    | P24V                       | 4G64-2<br>(2,4)  | x        | Enkel    | x                               | -                        | MPI                        | V5M21-2            | 5M/T          | x                             |       |   |   |                 |         |                 |   |
| L400               | PA4A<br>PB4V<br>PB4W       | 4G64-2<br>(2,4)  | x        | Enkel    | x                               | -                        | MPI                        | R5M21-7<br>R4AW2-5 | 5M/T<br>4A/T  | -<br>-                        |       |   |   |                 |         |                 |   |
|                    | PA3W                       | 4G63-A<br>(2,0)  | x        | Enkel    | x                               | -                        | CARB                       | R5M21-7<br>R4AW2-5 | 5M/T<br>4A/T  | -<br>-                        |       |   |   |                 |         |                 |   |

## 1998 modellen voor Australië

| Voertuig-<br>model | Voertuig<br>model-<br>code | Motor            |          |          |                                 |                          | Brand-<br>stof-<br>systeem | Versnelingsbak     |              |                               |
|--------------------|----------------------------|------------------|----------|----------|---------------------------------|--------------------------|----------------------------|--------------------|--------------|-------------------------------|
|                    |                            | Model<br>(liter) | Balansas | Nokkenas | Hydrau-<br>lische<br>klepstoter | Turbo<br>compres-<br>sor |                            | Model              | Type         | Vierwiel-<br>aandrij-<br>ving |
| Sigma              | F36A                       | 6G72-5<br>(3,0)  | -        | Dubbel   | x                               | -                        | MPI                        | F5M51-1<br>F4A51-2 | 5M/T<br>4A/T | -<br>-                        |
| 3000GT             | Z16A                       | 6G72-4<br>(3,0)  | -        | Vier     | x                               | x                        | MPI                        | W5MG1-2            | 5M/T         | x                             |



## 1999 modellen voor Europa

| Voertuig-<br>model | Voertuig<br>model-<br>code | Motor            |          |          |                                 |                          | Brand-<br>stof-<br>systeem | Versnelingsbak                |                      |                               |
|--------------------|----------------------------|------------------|----------|----------|---------------------------------|--------------------------|----------------------------|-------------------------------|----------------------|-------------------------------|
|                    |                            | Model<br>(liter) | Balansas | Nokkenas | Hydrau-<br>lische<br>klepstoter | Turbo<br>compres-<br>sor |                            | Model                         | Type                 | Vierwiel-<br>aandrij-<br>ving |
| Space<br>Star      | DG1A                       | 4G13-6<br>(1,3)  | –        | Enkel    | –                               | –                        | MPI                        | JB3-241                       | 5M/T                 | –                             |
|                    | DG5A                       | 4F93-G<br>(1,8)  | –        | Dubbel   | ×                               | –                        | GDI                        | F5M42-1                       | 5M/T                 | –                             |
| Space<br>Runner    | N61W                       | 4G93-G<br>(1,8)  | –        | Dubbel   | ×                               | –                        | GDI                        | F5M42-1<br>F4A42-1            | 5M/T<br>4A/T         | –<br>–                        |
| Space<br>Wagon     | N84W                       | 4G64-G<br>(2,4)  | –        | Dubbel   | ×                               | –                        | GDI                        | F5M42-2<br>F4A42-2            | 5M/T<br>4A/T         | –<br>–                        |
|                    | N94W                       | 4G64-G<br>(2,4)  | –        | Dubbel   | ×                               | –                        | GDI                        | F5M42-2<br>F4A42-2            | 5M/T<br>4A/T         | –<br>–                        |
| Galant             | EA2A<br>EA2W               | 4G63-6<br>(2,0)  | ×        | Enkel    | ×                               | –                        | MPI                        | F5M42-2<br>F4A42-2            | 5M/T<br>4A/T         | –<br>–                        |
|                    | EA3A<br>EA3W               | 4A64-4<br>(2,4)  | ×        | Dubbel   | ×                               | –                        | GDI                        | F5M42-2<br>F4A42-2            | 5M/T<br>4A/T         | –<br>–                        |
|                    | EA5A<br>EA5W               | 6A13-4<br>(2,5)  | –        | Dubbel   | ×                               | –                        | MPI                        | F5M42-2<br>F4A42-2            | 5M/T<br>4A/T         | –<br>–                        |
|                    | EA6A<br>EA6W               | 4D68-4<br>(2,0)  | ×        | Enkel    | –                               | ×                        | Diesel<br>S-RGS            | F5M42-2                       | 5M/T                 | –                             |
| Pajero/<br>Montero | V23C<br>V23W               | 6G72-8<br>(3,0)  | –        | Dubbel   | ×                               | –                        | MPI                        | V5MT1-6<br>V4AW3-B            | 5M/T<br>4A/T         | ×                             |
|                    | V24C<br>V24W<br>V44W       | 4D56-4<br>(2,5)  | ×        | Enkel    | –                               | ×                        | Diesel<br>S-RGS            | V5MT1-6                       | 5M/T                 | ×                             |
|                    | V25W<br>V45W               | 6G74-8<br>(3,5)  | –        | Vier     | ×                               | –                        | MPI                        | V5M31-5<br>V4AW3-B            | 5M/T<br>4A/T         | ×                             |
|                    | V26W                       | 4M40<br>(2,8)    | ×        | Enkel    | –                               | ×                        | Diesel<br>S-RGS            | V5M31-5                       | 5M/T                 | ×                             |
|                    | V43W                       | 6G72-8<br>(3,0)  | –        | Dubbel   | ×                               | –                        | MPI                        | V5MT1-6<br>V4AW3-B<br>V4AW3-7 | 5M/T<br>4A/T<br>4A/T | ×                             |
|                    | V46W                       | 4M40<br>(2,8)    | ×        | Enkel    | –                               | ×                        | Diesel<br>S-RGS            | V5M31-5<br>V4AW3-B            | 5M/T<br>4A/T         | ×                             |

1999 modellen voor Europa

| Voertuigmodel | Voertuigmodelcode | Motor         |          |            |                         |                  | Brandstofsysteem | Versnelingsbak     |              |                     |
|---------------|-------------------|---------------|----------|------------|-------------------------|------------------|------------------|--------------------|--------------|---------------------|
|               |                   | Model (liter) | Balansas | Nokkenas   | Hydraulische klepstoter | Turbo compressor |                  | Model              | Type         | Vierwielaandrijving |
| L200          | K62T              | 4G63-6 (2,0)  | ×        | Enkel      | ×                       | –                | MPI              | R5M21-5<br>R4AW2-6 | 5M/T<br>4A/T | –<br>–              |
|               | K64T              | 4D56-4 (2,5)  | ×        | Enkel      | –                       | –                | Diesel S-RGS     | R5M21-5            | 5M/T         | –                   |
|               | K74T              | 4D56-4 (2,5)  | ×        | Enkel      | –                       | ×                | Diesel S-RGS     | V5MT1-4<br>V4AW2-6 | 5M/T<br>4A/T | ×                   |
|               | K75T              | 4G64-2 (2,4)  | ×        | Enkel      | ×                       | –                | MPI              | V5M21-9            | 5M/T         | ×                   |
| Pajero Sport  | K94W              | 4D56-4 (2,4)  | ×        | Enkel      | –                       | ×                | Diesel S-RGS     | V5MT1-4            | 5M/T         | ×                   |
|               | K96W              | 6G72-8 (3,0)  | ×        | Dubbel × 2 | ×                       | –                | MPI              | V5MT1-4<br>V5MT1-6 | 5M/T<br>5M/T | ×                   |
| Pajero Pinin  | H76W              | 4G93-H (1,8)  | ×        | Dubbel     | ×                       | –                | GDI              | V5M21-A<br>V4AW4-D | 5M/T<br>4A/T | ×                   |
| L300          | P03V<br>P13V      | 4G63-6 (2,0)  | ×        | Enkel      | ×                       | –                | MPI              | R5M21-2            | 5M/T         | –                   |
|               | P05V<br>P15V      | 4D56-4 (2,5)  | ×        | Enkel      | –                       | ×                | Diesel S-RGS     | R5M21-2            | 5M/T         | –                   |
|               | P13T              | 4G63-6 (2,0)  | ×        | Enkel      | ×                       | –                | MPI              | R5M21-8            | 5M/T         | –                   |
|               | P15T              | 4D56-4 (2,5)  | ×        | Enkel      | –                       | ×                | Diesel S-RGS     | R5M21-8            | 5M/T         | –                   |
|               | P45V              | 4D56-4 (2,5)  | ×        | Enkel      | –                       | ×                | Diesel S-RGS     | V5M21-2            | 5M/T         | ×                   |
| L400          | PA3V<br>PB3V      | 4G63-6 (2,0)  | ×        | Enkel      | ×                       | –                | MPI              | R5M21-7            | 5M/T         | –                   |
|               | PA5V<br>PB5V      | 4D56-4 (2,5)  | ×        | Enkel      | –                       | ×                | Diesel S-RGS     | R5M21-7            | 5M/T         | –                   |
|               | PD4V              | 4G64-2 (2,4)  | ×        | Enkel      | ×                       | –                | MPI              | V5M21-7            | 5M/T         | ×                   |
|               | PD5V              | 4D56-2 (2,5)  | ×        | Enkel      | –                       | ×                | Diesel S-RGS     | V5M21-7            | 5M/T         | ×                   |

## 1999 modellen voor Europa

| Voertuig-<br>model | Voertuig<br>model-<br>code | Motor            |          |          |                                 |                          | Brand-<br>stof-<br>systeem | Versnelingsbak                |                      |                               |
|--------------------|----------------------------|------------------|----------|----------|---------------------------------|--------------------------|----------------------------|-------------------------------|----------------------|-------------------------------|
|                    |                            | Model<br>(liter) | Balansas | Nokkenas | Hydrau-<br>lische<br>klepstoter | Turbo<br>compres-<br>sor |                            | Model                         | Type                 | Vierwiel-<br>aandrij-<br>ving |
| Space<br>Gear      | PA3W                       | 4G63-6<br>(2,0)  | ×        | Enkel    | ×                               | –                        | MPI                        | R5M21-7<br>R4AW2-5            | 5M/T<br>4A/T         | –<br>–                        |
|                    | PA4W                       | 4G64-2<br>(2,4)  | ×        | Enkel    | ×                               | –                        | MPI                        | R5M21-7<br>R4AW2-5<br>R4AW2-8 | 5M/T<br>4A/T<br>4A/T | –<br>–<br>–                   |
|                    | PA5W                       | 4D56-4<br>(2,5)  | ×        | Enkel    | –                               | ×                        | Diesel<br>S-RGS            | R5M31-7                       | 5M/T                 | –                             |
|                    | PD4W                       | 4G64-2<br>(2,4)  | ×        | Enkel    | ×                               | –                        | MPI                        | V5M21-7                       | 5M/T                 | ×                             |
|                    | PD5W                       | 4D56-4<br>(2,5)  | ×        | Enkel    | –                               | ×                        | Diesel<br>S-RGS            | V5M31-7                       | 5M/T                 | ×                             |
| 3000GT             | Z16A                       | 6G72-4<br>(3,0)  | –        | Vier     | ×                               | ×                        | MPI                        | W6MG1-0                       | 6M/T                 | ×                             |
| Eclipse            | D32A                       | 4G63-7<br>(2,0)  | ×        | Dubbel   | ×                               | –                        | MPI                        | F5M31-2                       | 5M/T                 | ×                             |

## 1999 modellen voor algemene export

| Voertuig-<br>model | Voertuig-<br>model-<br>code | Motor            |          |          |                                 |                          | Brand-<br>stof-<br>systeem | Versnelingsbak     |              |                               |
|--------------------|-----------------------------|------------------|----------|----------|---------------------------------|--------------------------|----------------------------|--------------------|--------------|-------------------------------|
|                    |                             | Model<br>(liter) | Balansas | Nokkenas | Hydrau-<br>lische<br>klepstoter | Turbo<br>compres-<br>sor |                            | Model              | Type         | Vierwiel-<br>aandrij-<br>ving |
| Colt               | CJ1A                        | 4G13-5<br>(1,3)  | -        | Enkel    | -                               | -                        | CARB                       | F5M41-1            | 5M/T         | -                             |
|                    | CJ2A                        | 4G15-5<br>(1,5)  | -        | Enkel    | -                               | -                        | CARB                       | F5M41-1<br>F4A41-1 | 5M/T<br>4A/T | -<br>-                        |
|                    | CJ4A                        | 4G92-3<br>(1,6)  | -        | Enkel    | -                               | -                        | MPI                        | F5M41-1<br>F4A41-1 | 5M/T<br>4A/T | -<br>-                        |
| Lancer             | CB1W                        | 4G13-2<br>(1,3)  | -        | Enkel    | -                               | -                        | CARB                       | F5M21-1<br>F3A21-2 | 5M/T<br>3A/T | -<br>-                        |
|                    | CB2W                        | 4G15-2<br>(1,5)  | -        | Enkel    | -                               | -                        | CARB                       | F5M21-1<br>F3A21-2 | 5M/T<br>3A/T | -<br>-                        |
|                    | CK1A                        | 4G13-5<br>(1,3)  | -        | Enkel    | -                               | -                        | CARB                       | F5M41-1<br>F4A41-1 | 5M/T<br>4A/T | -<br>-                        |
|                    | CK2A                        | 4G15-5<br>(1,5)  | -        | Enkel    | -                               | -                        | CARB                       | F5M41-1<br>F4A41-1 | 5M/T<br>4A/T | -<br>-                        |
|                    | CK4A                        | 4G92-3<br>(1,6)  | -        | Enkel    | -                               | -                        | MPI                        | F5M41-1<br>F4A41-1 | 5M/T<br>4A/T | -<br>-                        |
| Space<br>Wagon     | N84W                        | 4G64-2<br>(2,4)  | x        | Dubbel   | x                               | -                        | GDI                        | F5M42-2<br>F4A42-2 | 5M/T<br>4A/T | -<br>-                        |
| Galant             | EA1A                        | 4G93-9<br>(1,8)  | -        | Enkel    | -                               | -                        | CARB                       | F5M42-1<br>F4A42-1 | 5M/T<br>4A/T | -<br>-                        |
|                    | EA2A                        | 4G63-E<br>(2,0)  | x        | Enkel    | x                               | -                        | MPI                        | F5M42-1<br>F4A42-1 | 5M/T<br>4A/T | -<br>-                        |
|                    | EA5A                        | 6A13-4<br>(2,5)  | -        | Dubbel   | x                               | -                        | MPI                        | F5M42-2<br>F4A42-2 | 5M/T<br>4A/T | -<br>-                        |
|                    | EA6A                        | 4D68-2<br>(2,0)  | x        | Enkel    | -                               | x                        | Diesel<br>S-RGS            | F5M42-2            | 5M/T         | -                             |
| Pajero/<br>Montero | V11V<br>V31V                | 4G64-6<br>(2,4)  | x        | Enkel    | -                               | -                        | CARB                       | V5M21-6            | 5M/T         | x                             |
|                    | V11W<br>V31V                | 4G64-2<br>(2,4)  | x        | Enkel    | -                               | -                        | MPI                        | V5M21-6            | 5M/T         | x                             |
|                    | V13V<br>V33V                | 6G72-1<br>(3,0)  | -        | Dubbel   | x                               | -                        | MPI                        | V5MT1-6            | 5M/T         | x                             |

## 1999 modellen voor algemene export

| Voertuig-<br>model | Voertuig-<br>model-<br>code | Motor            |          |          |                                 |                          | Brand-<br>stof-<br>systeem | Versnelingsbak     |              |                               |
|--------------------|-----------------------------|------------------|----------|----------|---------------------------------|--------------------------|----------------------------|--------------------|--------------|-------------------------------|
|                    |                             | Model<br>(liter) | Balansas | Nokkenas | Hydrau-<br>lische<br>klepstoter | Turbo<br>compres-<br>sor |                            | Model              | Type         | Vierwiel-<br>aandrij-<br>ving |
| Pajero/<br>Montero | V14C<br>V24W                | 4D56-4<br>(2,5)  | ×        | Enkel    | –                               | ×                        | Diesel<br>S-RGS            | V5MT1-6            | 5M/T         | ×                             |
|                    | V14V<br>V34V                | 4D56-4<br>(2,5)  | ×        | Enkel    | –                               | –                        | Diesel<br>S-RGS            | V5M21-6            | 5M/T         | ×                             |
|                    | V23W                        | 6G72-8<br>(3,0)  | –        | Dubbel   | ×                               | –                        | MPI                        | V5MT1-6            | 5M/T         | ×                             |
|                    |                             | 6G72-1<br>(3,0)  | –        | Dubbel   | ×                               | –                        | MPI                        | V5MT1-6<br>V4AW2-7 | 5M/T<br>4A/T | ×                             |
|                    | V25W<br>V45W                | 6G74-1<br>(3,5)  | –        | Vier     | ×                               | –                        | MPI                        | V5M31-5<br>V4AW3-B | 5M/T<br>4A/T | ×                             |
|                    | V31W                        | 4G64-2<br>(2,4)  | ×        | Enkel    | –                               | –                        | MPI                        | V5M21-6<br>V4AW2-A | 5M/T<br>4A/T | ×                             |
|                    | V36V<br>V36W                | 4M40<br>(2,8)    | ×        | Enkel    | –                               | –                        | Diesel<br>S-RGS            | V5M21-6            | 5M/T         | ×                             |
|                    | V43W                        | 6G72-1<br>(3,0)  | –        | Dubbel   | –                               | ×                        | MPI                        | V5M21-6<br>V4AW2-7 | 5M/T<br>4A/T | ×                             |
|                    |                             | 6G72-8<br>(3,0)  | –        | Dubbel   | ×                               | –                        | MPI                        | V5M21-6<br>V4AW3-7 | 5M/T<br>4A/T | ×                             |
|                    | V44W                        | 4D56-4<br>(2,5)  | ×        | Enkel    | ×                               | –                        | Diesel<br>S-RGS            | V4AW3-7            | 4A/T         | ×                             |
| V46W               | 4M40<br>(2,8)               | ×                | Enkel    | –        | ×                               | Diesel<br>S-RGS          | V5M31-5<br>V4AW3-B         | 5M/T<br>4A/T       | ×            |                               |
| L200               | K62T                        | 4G63-6<br>(2,0)  | ×        | Enkel    | ×                               | –                        | MPI                        | R5M21-5            | 5M/T         | –                             |
|                    |                             | 4G63-B<br>(2,0)  | ×        | Enkel    | ×                               | –                        | MPI                        | R5M21-5            | 5M/T         | –                             |
|                    | K64T                        | 4D56-4<br>(2,5)  | ×        | Enkel    | –                               | ×                        | Diesel<br>S-RGS            | R5M21-5            | 5M/T         | –                             |
|                    | K65T                        | 4G64-2<br>(2,4)  | ×        | Enkel    | ×                               | –                        | MPI                        | R5M21-5            | 5M/T         | –                             |

## 1999 modellen voor algemene export

| Voertuig-<br>model | Voertuig<br>model-<br>code | Motor            |          |                 |                                 |                          | Brand-<br>stof-<br>systeem | Versnelingsbak     |                 |                               |
|--------------------|----------------------------|------------------|----------|-----------------|---------------------------------|--------------------------|----------------------------|--------------------|-----------------|-------------------------------|
|                    |                            | Model<br>(liter) | Balansas | Nokkenas        | Hydrau-<br>lische<br>klepstoter | Turbo<br>compres-<br>sor |                            | Model              | Type            | Vierwiel-<br>aandrij-<br>ving |
| L200               | K72T                       | 4G63-6<br>(2,0)  | x        | Enkel           | x                               | -                        | CARB                       | V5M21-9            | 5M/T            | x                             |
|                    |                            | 4G63-B<br>(2,0)  | x        | Enkel           | x                               | -                        | CARB                       | V5M21-9            | 5M/T            | x                             |
|                    |                            | 4G64-2<br>(2,4)  | x        | Enkel           | x                               | -                        | MPI                        | V5M21-9            | 5M/T            | x                             |
|                    | K74T                       | 4D56-4<br>(2,5)  | x        | Enkel           | -                               | x                        | Diesel<br>S-RGS            | V5M21-9<br>V5MT1-4 | 5M/T<br>5M/T    | x<br>x                        |
|                    |                            |                  | K75T     | 4D56-4<br>(2,5) | x                               | Enkel                    | -                          | x                  | Diesel<br>S-RGS | V5MT1-4                       |
| Pajero<br>io       | H65W                       | 4G18-6<br>(1,6)  | -        | Enkel           | x                               | -                        | MPI                        | V5M21-A<br>V4AW4-D | 5M/T<br>4A/T    | x<br>x                        |
|                    | H76W                       | 4G93-D<br>(1,8)  | -        | Dubbel          | x                               | -                        | GDI                        | V5M21-A<br>V4AW4-D | 5M/T<br>4A/T    | x<br>x                        |
| L300               | P03V<br>P03W<br>P13W       | 4G63-B<br>(2,0)  | x        | Enkel           | x                               | -                        | CARB                       | R5M21-2            | 5M/T            | -                             |
|                    | P03W                       | 4G63-B<br>(2,0)  | x        | Enkel           | x                               | -                        | CARB                       | R4AW2-8            | 4A/T            | -                             |
|                    | P06V<br>P16V               | 4G92-0<br>(1,6)  | -        | Enkel           | -                               | -                        | CARB                       | R5M21-2            | 5M/T            | -                             |
|                    | P13V                       | 4G63-6<br>(2,0)  | x        | Enkel           | x                               | -                        | MPI                        | R5M21-2            | 5M/T            | -                             |
|                    |                            |                  | x        | Enkel           | x                               | -                        | CARB                       | R5M21-2            | 5M/T            | -                             |
|                    | P15V<br>P15W               | 4D56-4<br>(2,5)  | x        | Enkel           | -                               | -                        | Diesel<br>S-RGS            | R5M21-2            | 5M/T            | -                             |
|                    | P23W                       | 4G63-B<br>(2,0)  | x        | Enkel           | x                               | -                        | CARB                       | V5M21-2            | 5M/T            | x                             |
| L400               | PB3V                       | 4G63-B<br>(2,0)  | -        | Enkel           | x                               | -                        | CARB                       | R5M21-7            | 5M/T            | -                             |

## 1999 modellen voor algemene export

| Voertuig-<br>model | Voertuig<br>model-<br>code | Motor            |          |          |                                 |                          | Brand-<br>stof-<br>systeem | Versnelingsbak     |              |                               |
|--------------------|----------------------------|------------------|----------|----------|---------------------------------|--------------------------|----------------------------|--------------------|--------------|-------------------------------|
|                    |                            | Model<br>(liter) | Balansas | Nokkenas | Hydrau-<br>lische<br>klepstoter | Turbo<br>compres-<br>sor |                            | Model              | Type         | Vierwiel-<br>aandrij-<br>ving |
| Space<br>Gear      | PA3W                       | 4G63-B<br>(2,0)  | ×        | Enkel    | ×                               | –                        | CARB                       | R4AW2-5            | 4A/T         | –                             |
|                    | PA4W                       | 4G64-2<br>(2,4)  | ×        | Enkel    | ×                               | –                        | MPI                        | R5M21-7<br>R4AW2-5 | 5M/T<br>4A/T | –<br>–                        |
|                    | PA5W<br>PC5W               | 4D56-4<br>(2,5)  | ×        | Enkel    | –                               | ×                        | Diesel<br>S-RGS            | R5M21-7            | 5M/T         | –                             |
|                    | PC3W                       | 4G63-B<br>(2,0)  | ×        | Enkel    | ×                               | –                        | CARB                       | R5M21-7            | 5M/T         | –                             |
|                    | PD3W                       | 4G63-B<br>(2,0)  | ×        | Enkel    | ×                               | –                        | CARB                       | V5M21-7            | 5M/T         | ×                             |
|                    | PD4W                       | 4G64-2<br>(2,4)  | ×        | Enkel    | ×                               | –                        | MPI                        | V5M21-7            | 5M/T         | ×                             |
|                    | PD5W                       | 4D56-4<br>(2,5)  | ×        | Enkel    | –                               | ×                        | Diesel<br>S-RGS            | V5M21-7            | 5M/T         | ×                             |
| Sigma              | F36A                       | 6G72-5<br>(3,0)  | –        | Dubbel   | ×                               | –                        | MPI                        | F4A51-2            | 4A/T         | –                             |
| 3000GT             | Z16A                       | 6G72-4<br>(3,0)  | –        | Vier     | ×                               | ×                        | MPI                        | W5MG1-2            | 5M/T         | ×                             |

1999 modellen voor Australië

| Voertuig-<br>model | Voertuig<br>model-<br>code | Motor            |          |          |                                 |                          | Brand-<br>stof-<br>systeem | Versnelingsbak     |              |                               |
|--------------------|----------------------------|------------------|----------|----------|---------------------------------|--------------------------|----------------------------|--------------------|--------------|-------------------------------|
|                    |                            | Model<br>(liter) | Balansas | Nokkenas | Hydrau-<br>lische<br>klepstoter | Turbo<br>compres-<br>sor |                            | Model              | Type         | Vierwiel-<br>aandrij-<br>ving |
| Colt               | CJ2A                       | 4G15-3<br>(1,5)  | -        | Enkel    | x                               | -                        | MPI                        | F5M41-1<br>F4A41-1 | 5M/T<br>4A/T | -<br>-                        |
|                    | CJ5A                       | 4G93-3<br>(1,8)  | -        | Enkel    | x                               | -                        | MPI                        | F5M41-1<br>F4A41-1 | 5M/T<br>4A/T | -<br>-                        |
| Lancer             | CB5W                       | 4G93-0<br>(1,8)  | -        | Enkel    | x                               | -                        | MPI                        | F5M22-2<br>F4A22-2 | 5M/T<br>4A/T | -<br>-                        |
|                    | CK2A                       | 4G15-3<br>(1,5)  | -        | Enkel    | x                               | -                        | MPI                        | F5M41-1<br>F4A41-1 | 5M/T<br>4A/T | -<br>-                        |
|                    | CK5A                       | 4G93-3<br>(1,8)  | -        | Enkel    | x                               | -                        | MPI                        | F5M41-1<br>F4A41-1 | 5M/T<br>4A/T | -<br>-                        |
| Space<br>Wagon     | N84W                       | 4G64-2<br>(2,4)  | x        | Enkel    | x                               | -                        | MPI                        | F5M42-2<br>F4A42-2 | 5M/T<br>4A/T | -<br>-                        |
| Pajero/<br>Montero | V25W<br>V45W               | 6G74-8<br>(3,5)  | -        | Vier     | x                               | -                        | MPI                        | V5M31-5<br>V4AW3-B | 5M/T<br>4A/T | x<br>x                        |
|                    | V46W                       | 4M40<br>(2,8)    | x        | Enkel    | -                               | x                        | Diesel<br>S-RGS            | V5M31-5            | 5M/T         | x                             |
| Pajero<br>io       | H65W                       | 4G18-6<br>(1,8)  | -        | Enkel    | x                               | -                        | MPI                        | V5M21-A            | 5M/T         | x                             |
|                    | H76W                       | 4G93-D<br>(1,8)  | -        | Enkel    | x                               | -                        | MPI                        | V5M21-A<br>V4AW4-D | 5M/T<br>4A/T | x<br>x                        |
| L200               | K65T                       | 4G64-2<br>(2,4)  | x        | Enkel    | x                               | -                        | MPI                        | R5M21-5<br>R4AW2-6 | 5M/T<br>4A/T | -<br>-                        |
|                    | K67T                       | 4M40<br>(2,8)    | x        | Enkel    | -                               | -                        | Diesel<br>S-RGS            | R5M21-5            | 5M/T         | -                             |
|                    | K76T                       | 6G72-8<br>(3,0)  | -        | Dubbel   | x                               | -                        | MPI                        | V5MT1-4<br>V4AW3-6 | 5M/T<br>4A/T | x<br>x                        |
|                    | K77T                       | 4M40<br>(2,8)    | x        | Enkel    | -                               | -                        | Diesel<br>S-RGS            | V5M21-9            | 5M/T         | x                             |
| Challenger         | K96W                       | 6G72-8<br>(3,0)  | -        | Dubbel   | x                               | -                        | MPI                        | V5MT1-4<br>V4AW3-6 | 5M/T<br>4A/T | x<br>x                        |



## 1999 modellen voor Australië

| Voertuig-<br>model | Voertuig<br>model-<br>code | Motor            |          |          |                                 |                          | Brand-<br>stof-<br>systeem | Versnelingsbak     |              |                               |
|--------------------|----------------------------|------------------|----------|----------|---------------------------------|--------------------------|----------------------------|--------------------|--------------|-------------------------------|
|                    |                            | Model<br>(liter) | Balansas | Nokkenas | Hydrau-<br>lische<br>klepstoter | Turbo<br>compres-<br>sor |                            | Model              | Type         | Vierwiel-<br>aandrij-<br>ving |
| L300               | P03V                       | 4G63-A<br>(2,0)  | x        | Enkel    | x                               | -                        | CARB                       | R5M21-2<br>R4AW2-8 | 5M/T<br>4A/T | -<br>-                        |
|                    | P03W                       | 4G63-6<br>(2,0)  | x        | Enkel    | x                               | -                        | MPI                        | R5M21-2<br>R4AW2-8 | 5M/T<br>4A/T | -<br>-                        |
|                    | P05V<br>P15V<br>P25V       | 4D56-4<br>(2,5)  | x        | Enkel    | -                               | -                        | Diesel<br>S-RGS            | R5M21-2            | 5M/T         | -                             |
|                    | P15V                       | 4G56-2<br>(2,5)  | x        | Enkel    | -                               | -                        | Diesel<br>S-RGS            | R5M21-2            | 5M/T         | -                             |
|                    | P14V<br>P04W               | 4G64-2<br>(2,4)  | x        | Enkel    | x                               | -                        | MPI                        | R5M21-2<br>R4AW2-8 | 5M/T<br>4A/T | -<br>-                        |
|                    | P04V<br>P24V<br>P14W       | 4G64-2<br>(2,4)  | x        | Enkel    | x                               | -                        | MPI                        | V5M21-2            | 5M/T         | x                             |
| L400               | PA3V                       | 4G63-6<br>(2,0)  | x        | Enkel    | x                               | -                        | MPI                        | R5M21-7<br>R4AW2-5 | 5M/T<br>4A/T | -<br>-                        |
|                    | PD4A<br>PB4W               | 4G64-2<br>(2,4)  | x        | Enkel    | x                               | -                        | MPI                        | R5M21-7            | 5M/T         | -                             |
|                    | PA4W<br>PB4V               | 4G64-2<br>(2,4)  | x        | Enkel    | x                               | -                        | MPI                        | R5M21-7<br>R4AW2-5 | 5M/T<br>4A/T | -<br>-                        |
|                    | PA3W                       | 4G63-6<br>(2,0)  | x        | Enkel    | x                               | -                        | MPI                        | R5M21-7<br>R4AW2-5 | 5M/T<br>4A/T | -<br>-                        |
| Sigma              | F36A                       | 6G72-5<br>(3,0)  | -        | Dubbel   | x                               | -                        | MPI                        | F5M51-1<br>F4A51-2 | 5M/T<br>4A/T | -<br>-                        |
|                    | F38A                       | 6G74-5<br>(3,5)  | -        | Dubbel   | x                               | -                        | MPI                        | F5M51-1<br>F4A51-2 | 5M/T<br>4A/T | -<br>-                        |
| Magna              | F36W                       | 6G72-5<br>(3,0)  | -        | Dubbel   | x                               | -                        | MPI                        | F5M51-1<br>F4A51-2 | 5M/T<br>4A/T | -<br>-                        |
|                    | F38W                       | 6G74-5<br>(3,5)  | -        | Dubbel   | x                               | -                        | MPI                        | F5M51-1<br>F4A51-2 | 5M/T<br>4A/T | -<br>-                        |
| 3000GT             | Z16A                       | 6G72-4<br>(3,0)  | -        | Vier     | x                               | x                        | MPI                        | W5MG1-2            | 5M/T         | x                             |

## 2000 modellen voor Europa

| Voertuig-<br>model         | Voertuig<br>model-<br>code | Motor            |          |          |                                 |                          | Brand-<br>stof-<br>systeem | Versnelingsbak                |                      |                               |
|----------------------------|----------------------------|------------------|----------|----------|---------------------------------|--------------------------|----------------------------|-------------------------------|----------------------|-------------------------------|
|                            |                            | Model<br>(liter) | Balansas | Nokkenas | Hydrau-<br>lische<br>klepstoter | Turbo<br>compres-<br>sor |                            | Model                         | Type                 | Vierwiel-<br>aandrij-<br>ving |
| Lancer<br>Station<br>Wagon | CB4W                       | 4G92-0<br>(1,6)  | –        | Enkel    | –                               | –                        | MPI                        | F5M22-2<br>F4A22-2            | 5M/T<br>4A/T         | –<br>–                        |
|                            | CD4W                       | 4G92-0<br>(1,6)  | –        | Enkel    | –                               | –                        | MPI                        | W5M31-2                       | 5M/T                 | ×                             |
| Colt                       | CJ1A<br>CK1A               | 4G13-3<br>(1,3)  | –        | Enkel    | –                               | –                        | MPI                        | F5M41-1<br>F4A41-1            | 5M/T<br>4A/T         | –<br>–                        |
|                            | CJ4A                       | 4G92-3<br>(1,6)  | –        | Enkel    | –                               | –                        | MPI                        | F5M41-1<br>F4A41-1            | 5M/T<br>4A/T         | –<br>–                        |
| Carisma                    | DA1A                       | 4G92-2<br>(1,6)  | –        | Enkel    | –                               | –                        | MPI                        | JB3-242<br>F4A41-1            | 5M/T<br>4A/T         | –<br>–                        |
|                            | DA2A                       | 4G93-G<br>(1,8)  | –        | Dubbel   | ×                               | –                        | GDI                        | F5M42-1<br>F4A42-1            | 5M/T<br>4A/T         | –<br>–                        |
|                            | DA4A                       | F8QT-1<br>(1,9)  | –        | Enkel    | –                               | ×                        | Diesel<br>S-RGS            | JC5-225                       | 5M/T                 | –                             |
| Space<br>Runner            | N63W                       | 4G63-6<br>(2,0)  | ×        | Enkel    | –                               | –                        | MPI                        | F5M42-2<br>R5M21-8<br>F4A42-1 | 5M/T<br>5M/T<br>4A/T | –<br>–<br>–                   |
|                            | N64W                       | 4G64-4<br>(2,4)  | ×        | Dubbel   | ×                               | –                        | GDI                        | F5M42-2<br>F4A42-2            | 5M/T<br>4A/T         | –<br>–                        |
| Space<br>Wagon             | N84W                       | 4G64-4<br>(2,4)  | ×        | Dubbel   | ×                               | –                        | GDI                        | F5M42-2<br>F4A42-2            | 5M/T<br>4A/T         | –<br>–                        |
|                            | N94W                       | 4G64-4<br>(2,4)  | ×        | Dubbel   | ×                               | –                        | GDI                        | W5M42-1                       | 5M/T                 | ×                             |
| Pajero                     | V23C<br>V23W               | 6G72-8<br>(3,0)  | –        | Dubbel   | ×                               | –                        | MPI                        | V5MT1-6<br>V4AW3-B            | 5M/T<br>4A/T         | ×                             |
|                            | V24C<br>V24W<br>V44W       | 4D56-4<br>(2,5)  | ×        | Enkel    | –                               | ×                        | Diesel<br>S-RGS            | V5MT1-6                       | 5M/T                 | ×                             |
|                            | V25W<br>V45W               | 6G74-8<br>(3,5)  | –        | Dubbel   | ×                               | –                        | MPI                        | V5M31-5<br>V4AW3-B            | 5M/T<br>4A/T         | ×                             |
|                            | V26W                       | 4M40<br>(2,8)    | ×        | Enkel    | –                               | ×                        | Diesel<br>S-RGS            | V5M31-5                       | 5M/T                 | ×                             |

## 2000 modellen voor Europa

| Voertuig-<br>model | Voertuig-<br>model-<br>code | Motor            |          |          |                                 |                          | Brand-<br>stof-<br>systeem | Versnelingsbak     |              |                               |   |
|--------------------|-----------------------------|------------------|----------|----------|---------------------------------|--------------------------|----------------------------|--------------------|--------------|-------------------------------|---|
|                    |                             | Model<br>(liter) | Balansas | Nokkenas | Hydrau-<br>lische<br>klepstoter | Turbo<br>compres-<br>sor |                            | Model              | Type         | Vierwiel-<br>aandrij-<br>ving |   |
| Pajero             | V43W                        | 6G72-1<br>(3,0)  | –        | Dubbel   | ×                               | –                        | MPI                        | V5MT1-6<br>V4AW2-7 | 5M/T<br>4A/T | ×                             | × |
|                    |                             | 6G72-8<br>(3,0)  | –        | Dubbel   | ×                               | –                        | MPI                        | V5MT1-6<br>V4AW3-7 | 5M/T<br>4A/T | ×                             | × |
|                    | V46W                        | 4M40<br>(2,8)    | ×        | Enkel    | –                               | ×                        | Diesel<br>S-RGS            | V5M31-5<br>V4AW3-B | 5M/T<br>4A/T | ×                             | × |
| L200               | K62T                        | 4G63-6<br>(2,0)  | ×        | Enkel    | ×                               | –                        | MPI                        | R5M21-5<br>R4AW2-6 | 5M/T<br>4A/T | –                             | – |
|                    | K64T                        | 4D56-4<br>(2,5)  | ×        | Enkel    | –                               | –                        | Diesel<br>S-RGS            | R5M21-5            | 5M/T         | –                             | – |
|                    | K74T                        | 4D56-4<br>(2,5)  | ×        | Enkel    | –                               | ×                        | Diesel<br>S-RGS            | V5MT1-4<br>V4AW2-6 | 5M/T<br>4A/T | ×                             | × |
|                    | K75T                        | 4G64-2<br>(2,4)  | ×        | Enkel    | ×                               | –                        | MPI                        | V5M21-9            | 5M/T         | ×                             | × |
| Pajero<br>Sport    | K94W                        | 4D56-4<br>(2,4)  | ×        | Enkel    | –                               | ×                        | Diesel<br>S-RGS            | V5MT1-B            | 5M/T         | ×                             | × |
|                    | K96W                        | 6G72-8<br>(3,0)  | –        | Dubbel   | ×                               | –                        | MPI                        | V5MT1-B<br>V4A51-5 | 5M/T<br>4A/T | ×                             | × |
| L300               | P03V<br>P13V                | 4G63-6<br>(2,0)  | ×        | Enkel    | ×                               | –                        | MPI                        | R5M21-2            | 5M/T         | –                             | – |
|                    | P05V<br>P15V                | 4D56-4<br>(2,5)  | ×        | Enkel    | –                               | –                        | Diesel<br>S-RGS            | R5M21-2            | 5M/T         | –                             | – |
|                    | P13T                        | 4G63-6<br>(2,0)  | ×        | Enkel    | ×                               | –                        | MPI                        | R5M21-8            | 5M/T         | –                             | – |
|                    | P15T                        | 4D56-4<br>(2,5)  | ×        | Enkel    | –                               | ×                        | Diesel<br>S-RGS            | R5M21-8            | 5M/T         | –                             | – |
|                    | P45V                        | 4D56-4<br>(2,5)  | ×        | Enkel    | –                               | ×                        | Diesel<br>S-RGS            | V5M21-2            | 5M/T         | ×                             | × |
| L400               | PA3V<br>PB3V                | 4G63-6<br>(2,0)  | ×        | Enkel    | ×                               | –                        | MPI                        | R5M21-7            | 5M/T         | –                             | – |
|                    | PA5V<br>PB5V                | 4D56-4<br>(2,5)  | ×        | Enkel    | –                               | ×                        | Diesel<br>S-RGS            | R5M21-7            | 5M/T         | –                             | – |

## 2000 modellen voor Europa

| Voertuig-<br>model | Voertuig<br>model-<br>code | Motor            |          |          |                                 |                          | Brand-<br>stof-<br>systeem | Versnelingsbak     |              |                               |
|--------------------|----------------------------|------------------|----------|----------|---------------------------------|--------------------------|----------------------------|--------------------|--------------|-------------------------------|
|                    |                            | Model<br>(liter) | Balansas | Nokkenas | Hydrau-<br>lische<br>klepstoter | Turbo<br>compres-<br>sor |                            | Model              | Type         | Vierwiel-<br>aandrij-<br>ving |
| L400               | PD4V                       | 4G64-2<br>(2,4)  | ×        | Enkel    | ×                               | –                        | MPI                        | V5M21-7            | 5M/T         | ×                             |
|                    | PD5V                       | 4D56-4<br>(2,5)  | ×        | Enkel    | –                               | ×                        | Diesel<br>S-RGS            | V5M21-7            | 5M/T         | ×                             |
| Space<br>Gear      | PA3W                       | 4G63-6<br>(2,0)  | ×        | Enkel    | ×                               | –                        | MPI                        | R5M21-7            | 5M/T         | –                             |
|                    | PA4W                       | 4G64-2<br>(2,4)  | ×        | Enkel    | ×                               | –                        | MPI                        | R5M21-7<br>R4AW2-5 | 5M/T<br>4A/T | –<br>–                        |
|                    | PA5W                       | 4D56-4<br>(2,5)  | ×        | Enkel    | –                               | ×                        | Diesel<br>S-RGS            | R5M31-7            | 5M/T         | –                             |
|                    | PD4W                       | 4G64-2<br>(2,4)  | ×        | Enkel    | ×                               | –                        | MPI                        | V5M21-7            | 5M/T         | ×                             |
|                    | PD5W                       | 4D56-4<br>(2,5)  | ×        | Enkel    | –                               | ×                        | Diesel<br>S-RGS            | V5M31-7            | 5M/T         | ×                             |
| 3000GT             | Z16A                       | 6G72-4<br>(3,0)  | –        | Vier     | ×                               | ×                        | MPI                        | W6MG1-0            | 6M/T         | ×                             |

## 2000 modellen voor algemene export

| Voertuig-<br>model         | Voertuig<br>model-<br>code | Motor            |          |          |                                 |                          | Brand-<br>stof-<br>systeem | Versnelingsbak     |              |                               |
|----------------------------|----------------------------|------------------|----------|----------|---------------------------------|--------------------------|----------------------------|--------------------|--------------|-------------------------------|
|                            |                            | Model<br>(liter) | Balansas | Nokkenas | Hydrau-<br>lische<br>klepstoter | Turbo<br>compres-<br>sor |                            | Model              | Type         | Vierwiel-<br>aandrij-<br>ving |
| Colt                       | CJ1A                       | 4G13-5<br>(1,3)  | -        | Enkel    | -                               | -                        | CARB                       | F5M41-1<br>F4A41-1 | 5M/T<br>4A/T | -<br>-                        |
|                            | CJ2A                       | 4G15-5<br>(1,5)  | -        | Enkel    | -                               | -                        | CARB                       | F5M41-1<br>F4A41-1 | 5M/T<br>4A/T | -<br>-                        |
|                            | CJ4A                       | 4G13-5<br>(1,3)  | -        | Enkel    | -                               | -                        | CARB                       | F5M41-1<br>F4A41-1 | 5M/T<br>4A/T | -<br>-                        |
|                            |                            | 4G92-3<br>(1,6)  | -        | Enkel    | -                               | -                        | MPI                        | F5M41-1<br>F4A41-1 | 5M/T<br>4A/T | -<br>-                        |
|                            |                            | 4G92-3<br>(1,6)  | -        | Enkel    | -                               | -                        | MPI                        | F4A41-1            | 4A/T         | -                             |
| Lancer<br>Station<br>Wagon | CB1W                       | 4G13-2<br>(1,3)  | -        | Enkel    | -                               | -                        | CARB                       | F5M21-1<br>F3A21-2 | 5M/T<br>3A/T | -<br>-                        |
|                            | CB2W                       | 4G15-2<br>(1,5)  | -        | Enkel    | -                               | -                        | CARB                       | F5M21-1<br>F3A21-2 | 5M/T<br>3A/T | -<br>-                        |
|                            | CB4W                       | 4G92-0<br>(1,6)  | -        | Enkel    | -                               | -                        | MPI                        | F5M22-2<br>F4A22-2 | 5M/T<br>4A/T | -<br>-                        |
| Lancer                     | CK1A                       | 4G13-5<br>(1,3)  | -        | Enkel    | -                               | -                        | CARB                       | F5M41-1<br>F4A41-1 | 5M/T<br>4A/T | -<br>-                        |
|                            |                            | 4G13-3<br>(1,3)  | -        | Enkel    | -                               | -                        | MPI                        | F5M41-1<br>F4A41-1 | 5M/T<br>4A/T | -<br>-                        |
|                            | CK2A                       | 4G15-5<br>(1,5)  | -        | Enkel    | -                               | -                        | CARB                       | F5M41-1<br>F4A41-1 | 5M/T<br>4A/T | -<br>-                        |
|                            |                            | 4G15-4<br>(1,5)  | -        | Dubbel   | x                               | -                        | MPI                        | F5M41-1<br>F4A41-1 | 5M/T<br>4A/T | -<br>-                        |
|                            | CK4A                       | 4G92-3<br>(1,6)  | -        | Enkel    | -                               | -                        | MPI                        | F5M41-1<br>F4A41-1 | 5M/T<br>4A/T | -<br>-                        |
|                            |                            | 4G92-7<br>(1,6)  | -        | Dubbel   | -                               | -                        | MPI                        | F5M42-1<br>F4A42-1 | 5M/T<br>4A/T | -<br>-                        |
| Mirage<br>Dingo            | CQ2A                       | 4G15-8<br>(1,5)  | -        | Dubbel   | x                               | -                        | GDI                        | F4A41-1            | 4A/T         | -                             |

## 2000 modellen voor algemene export

| Voertuig-<br>model | Voertuig-<br>model-<br>code | Motor            |          |          |                                 |                           | Brand-<br>stof-<br>systeem | Versnelingsbak     |              |                               |
|--------------------|-----------------------------|------------------|----------|----------|---------------------------------|---------------------------|----------------------------|--------------------|--------------|-------------------------------|
|                    |                             | Model<br>(liter) | Balansas | Nokkenas | Hydrau-<br>lische<br>klepstoter | Turbo-<br>compres-<br>sor |                            | Model              | Type         | Vierwiel-<br>aandrij-<br>ving |
| Space<br>Wagon     | N84W                        | 4G64-2<br>(2,4)  | x        | Enkel    | x                               | -                         | MPI                        | F5M42-2<br>F4A42-2 | 5M/T<br>4A/T | -<br>-                        |
|                    |                             | 4G64-4<br>(2,4)  | x        | Dubbel   | x                               | -                         | GDI                        | F4A42-2            | 4A/T         | -                             |
| Galant             | EA1A                        | 4G93-9<br>(1,8)  | -        | Enkel    | -                               | -                         | CARB                       | F5M42-1<br>F4A42-1 | 5M/T<br>4A/T | -<br>-                        |
|                    | EA2A                        | 4G63-E<br>(2,0)  | x        | Enkel    | x                               | -                         | CARB                       | F5M42-1<br>F4A42-1 | 5M/T<br>4A/T | -<br>-                        |
|                    |                             | 4G63-6<br>(2,0)  | x        | Enkel    | x                               | -                         | MPI                        | F5M42-1<br>F4A42-1 | 5M/T<br>4A/T | -<br>-                        |
|                    | EA5A                        | 6A13-4<br>(2,5)  | -        | Dubbel   | x                               | -                         | MPI                        | F5M42-2<br>F4A42-2 | 5M/T<br>4A/T | -<br>-                        |
| Pajero             | V11V<br>V31V                | 4G64-6<br>(2,4)  | x        | Enkel    | -                               | -                         | CARB                       | V5M21-6            | 5M/T         | x                             |
|                    | V11W<br>V31V                | 4G64-2<br>(2,4)  | x        | Enkel    | -                               | -                         | MPI                        | V5M21-6            | 5M/T         | x                             |
|                    | V13V<br>V33V<br>V33W        | 6G72-1<br>(3,0)  | -        | Dubbel   | x                               | -                         | MPI                        | V5MT1-6            | 5M/T         | x                             |
|                    |                             |                  |          |          |                                 |                           |                            | V4AW2-7            | 4A/T         | x                             |
|                    | V14V<br>V34V                | 4D56-4<br>(2,5)  | x        | Enkel    | -                               | -                         | Diesel<br>S-RGS            | V5M21-6            | 5M/T         | x                             |
|                    | V23W                        | 6G72-8<br>(3,0)  | -        | Dubbel   | x                               | -                         | MPI                        | V5MT1-6            | 5M/T         | x                             |
|                    |                             |                  |          |          |                                 |                           |                            |                    |              |                               |
|                    | V24W                        | 4D56-4<br>(2,5)  | x        | Enkel    | -                               | x                         | Diesel<br>S-RGS            | V5MT1-6            | 5M/T         | x                             |
| V25W<br>V45W       | 6G74-1<br>(3,5)             | -                | Vier     | x        | -                               | MPI                       | V5M31-5<br>V4AW3-B         | 5M/T<br>4A/T       | x<br>x       |                               |
|                    |                             |                  |          |          |                                 |                           |                            |                    |              | 6G74-8<br>(3,5)               |

## 2000 modellen voor algemene export

| Voertuig-<br>model | Voertuig<br>model-<br>code | Motor            |          |          |                                 |                          | Brand-<br>stof-<br>systeem | Versnelingsbak                |                      |                               |
|--------------------|----------------------------|------------------|----------|----------|---------------------------------|--------------------------|----------------------------|-------------------------------|----------------------|-------------------------------|
|                    |                            | Model<br>(liter) | Balansas | Nokkenas | Hydrau-<br>lische<br>klepstoter | Turbo<br>compres-<br>sor |                            | Model                         | Type                 | Vierwiel-<br>aandrij-<br>ving |
| Pajero             | V26W                       | 4M40<br>(2,8)    | ×        | Enkel    | –                               | ×                        | Diesel<br>S-RGS            | V5M31-5                       | 5M/T                 | ×                             |
|                    | V31W                       | 4G64-2<br>(2,4)  | ×        | Enkel    | –                               | –                        | MPI                        | V5M21-6<br>V4AW2-A            | 5M/T<br>4A/T         | ×                             |
|                    | V36V<br>V36W               | 4M40<br>(2,8)    | ×        | Enkel    | –                               | –                        | Diesel<br>S-RGS            | V5M21-6                       | 5M/T                 | ×                             |
|                    | V43W                       | 6G72-1<br>(3,0)  | –        | Dubbel   | ×                               | –                        | MPI                        | V5MT1-6<br>V4AW2-7            | 5M/T<br>4A/T         | ×                             |
|                    |                            | 6G72-8<br>(3,0)  | –        | Dubbel   | ×                               | –                        | MPI                        | V5MT1-6<br>V4AW3-7<br>V4AW3-B | 5M/T<br>4A/T<br>4A/T | ×                             |
|                    | V44W                       | 4D56-4<br>(2,5)  | ×        | Enkel    | –                               | ×                        | Diesel<br>S-RGS            | V5MT1-6<br>V4AW2-7            | 5M/T<br>4A/T         | ×                             |
|                    | V46W                       | 4M40<br>(2,8)    | ×        | Enkel    | –                               | ×                        | Diesel<br>S-RGS            | V5M31-5<br>V4AW3-B            | 5M/T<br>4A/T         | ×                             |
| L200               | K62T                       | 4G63-6<br>(2,0)  | ×        | Enkel    | ×                               | –                        | MPI                        | R5M21-5                       | 5M/T                 | –                             |
|                    |                            | 4G63-6<br>(2,0)  | –        | Enkel    | ×                               | –                        | CARB                       | R5M21-5                       | 5M/T                 | –                             |
|                    |                            | 4G63-B<br>(2,0)  | –        | Enkel    | ×                               | –                        | CARB                       | R5M21-5                       | 5M/T                 | –                             |
|                    | K64T                       | 4D56-3<br>(2,5)  | ×        | Enkel    | –                               | –                        | Diesel<br>S-RGS            | R5M21-5                       | 5M/T                 | –                             |
|                    |                            | 4D56-4<br>(2,5)  | ×        | Enkel    | –                               | –                        | Diesel<br>S-RGS            | R5M21-5                       | 5M/T                 | –                             |
|                    | K65T                       | 4G64-2<br>(2,4)  | ×        | Enkel    | ×                               | –                        | MPI                        | R5M21-5                       | 5M/T                 | –                             |
|                    | K67T                       | 4M40<br>(2,8)    | ×        | Enkel    | –                               | –                        | Diesel<br>S-RGS            | R5M21-5<br>R4AW2-6            | 5M/T<br>4A/T         | –                             |

## 2000 modellen voor algemene export

| Voertuig-<br>model | Voertuig-<br>model-<br>code | Motor            |                 |          |                                 |                          | Brand-<br>stof-<br>systeem | Versnelingsbak     |                    |                               |        |
|--------------------|-----------------------------|------------------|-----------------|----------|---------------------------------|--------------------------|----------------------------|--------------------|--------------------|-------------------------------|--------|
|                    |                             | Model<br>(liter) | Balansas        | Nokkenas | Hydrau-<br>lische<br>klepstoter | Turbo<br>compres-<br>sor |                            | Model              | Type               | Vierwiel-<br>aandrij-<br>ving |        |
| L200               | K72T                        | 4G63-6<br>(2,0)  | –               | Enkel    | ×                               | –                        | CARB                       | V5M21-9            | 5M/T               | ×                             |        |
|                    |                             | 4G63-B<br>(2,0)  | –               | Enkel    | ×                               | –                        | CARB                       | V5M21-9            | 5M/T               | ×                             |        |
|                    | K74T                        | 4D56-3<br>(2,5)  | ×               | Enkel    | –                               | ×                        | Diesel<br>S-RGS            | V5MT1-4            | 5M/T               | ×                             |        |
|                    |                             | 4D56-3<br>(2,5)  | ×               | Enkel    | –                               | –                        | Diesel<br>S-RGS            | V5M21-9            | 5M/T               | ×                             |        |
|                    |                             | 4D56-4<br>(2,5)  | ×               | Enkel    | –                               | –                        | Diesel<br>S-RGS            | V5M21-9            | 5M/T               | ×                             |        |
|                    |                             | 4D56-4<br>(2,5)  | ×               | Enkel    | –                               | ×                        | Diesel<br>S-RGS            | V5MT1-4            | 5M/T               | ×                             |        |
|                    | K75T                        | 4G64-2<br>(2,4)  | ×               | Enkel    | ×                               | –                        | MPI                        | V5M21-9            | 5M/T               | ×                             |        |
|                    | Challenger                  | K86W             | 6G72-8<br>(3,0) | –        | Dubbel                          | ×                        | –                          | MPI                | R5M31-B<br>R4A51-5 | 5M/T<br>4A/T                  | –<br>– |
|                    |                             | K96W             | 6G72-8<br>(3,0) | –        | Dubbel                          | ×                        | –                          | MPI                | V5MT1-B<br>V4A51-5 | 5M/T<br>4A/T                  | ×      |
|                    |                             | K97W             | 4M40<br>(2,8)   | ×        | Enkel                           | –                        | ×                          | Diesel<br>S-RGS    | V5M31-B<br>V4A51-5 | 5M/T<br>4A/T                  | ×      |
| L300               | P03V<br>P13V                | 4G63-B<br>(2,0)  | –               | Enkel    | ×                               | –                        | CARB                       | R5M21-2            | 5M/T               | –                             |        |
|                    | P03W                        | 4G63-B<br>(2,0)  | –               | Enkel    | ×                               | –                        | CARB                       | R5M21-2<br>R4AW2-8 | 5M/T<br>4A/T       | –<br>–                        |        |
|                    | P06V<br>P16V                | 4G92-0<br>(1,6)  | –               | Enkel    | –                               | –                        | CARB                       | R5M21-2            | 5M/T               | –                             |        |
|                    | P13W                        | 4G63-6<br>(2,0)  | ×               | Enkel    | ×                               | –                        | MPI                        | R5M21-2            | 5M/T               | –                             |        |
|                    |                             | 4G63-B<br>(2,0)  | –               | Enkel    | ×                               | –                        | CARB                       | R5M21-2            | 5M/T               | –                             |        |
|                    | P15V<br>P15W                | 4D56-2<br>(2,5)  | ×               | Enkel    | –                               | –                        | Diesel<br>S-RGS            | R5M21-2            | 5M/T               | –                             |        |



## 2000 modellen voor algemene export

| Voertuig-<br>model | Voertuig<br>model-<br>code | Motor            |          |          |                                 |                          | Brand-<br>stof-<br>systeem | Versnelingsbak |      |                               |
|--------------------|----------------------------|------------------|----------|----------|---------------------------------|--------------------------|----------------------------|----------------|------|-------------------------------|
|                    |                            | Model<br>(liter) | Balansas | Nokkenas | Hydrau-<br>lische<br>klepstoter | Turbo<br>compres-<br>sor |                            | Model          | Type | Vierwiel-<br>aandrij-<br>ving |
| L300               | P15V                       | 4D56-4<br>(2,5)  | ×        | Enkel    | –                               | –                        | Diesel<br>S-RGS            | R5M21-2        | 5M/T | –                             |
|                    | P23W                       | 4G63-B<br>(2,0)  | –        | Enkel    | ×                               | –                        | CARB                       | V5M21-2        | 5M/T | ×                             |
| L400               | PB3V                       | 4G63-B<br>(2,0)  | –        | Enkel    | ×                               | –                        | CARB                       | R5M21-7        | 5M/T | –                             |
|                    | PB5V                       | 4D56-4<br>(2,5)  | ×        | Enkel    | –                               | ×                        | Diesel<br>S-RGS            | R5M21-7        | 5M/T | –                             |
| Space<br>Gear      | PA3W                       | 4G63-B<br>(2,0)  | –        | Enkel    | ×                               | –                        | CARB                       | R4AW2-5        | 4A/T | –                             |
|                    | PA4W                       | 4G64-2<br>(2,4)  | ×        | Enkel    | ×                               | –                        | MPI                        | R4AW2-5        | 4A/T | –                             |
|                    | PA5W<br>PC5W               | 4D56-4<br>(2,5)  | ×        | Enkel    | –                               | ×                        | Diesel<br>S-RGS            | R5M21-7        | 5M/T | –                             |
|                    | PC3W                       | 4G63-B<br>(2,0)  | –        | Enkel    | ×                               | –                        | CARB                       | R5M21-7        | 5M/T | –                             |
|                    | PD3W                       | 4G63-B<br>(2,0)  | –        | Enkel    | ×                               | –                        | CARB                       | V5M21-7        | 5M/T | ×                             |
|                    | PD4W                       | 4G64-2<br>(2,4)  | ×        | Enkel    | ×                               | –                        | MPI                        | V5M21-7        | 5M/T | ×                             |
|                    | PD5W                       | 4D56-4<br>(2,5)  | ×        | Enkel    | –                               | ×                        | Diesel<br>S-RGS            | V5M21-7        | 5M/T | ×                             |
| Sigma              | F36A                       | 6G72-5<br>(3,0)  | –        | Dubbel   | ×                               | –                        | MPI                        | F4A51-2        | 4A/T | –                             |
| 3000GT             | Z16A                       | 6G72-4<br>(3,0)  | –        | Vier     | ×                               | ×                        | MPI                        | W5MG1-2        | 5M/T | ×                             |

## 2000 modellen voor Australië

| Voertuig-<br>model         | Voertuig<br>model-<br>code | Motor            |          |          |                                 |                          | Brand-<br>stof-<br>systeem | Versnelingsbak     |              |                               |
|----------------------------|----------------------------|------------------|----------|----------|---------------------------------|--------------------------|----------------------------|--------------------|--------------|-------------------------------|
|                            |                            | Model<br>(liter) | Balansas | Nokkenas | Hydrau-<br>lische<br>klepstoter | Turbo<br>compres-<br>sor |                            | Model              | Type         | Vierwiel-<br>aandrij-<br>ving |
| Colt                       | CJ2A                       | 4G15-3<br>(1,5)  | -        | Enkel    | -                               | -                        | MPI                        | F5M41-1<br>F4A41-1 | 5M/T<br>4A/T | -<br>-                        |
|                            | CJ5A                       | 4G93-3<br>(1,8)  | -        | Enkel    | -                               | -                        | MPI                        | F5M42-1<br>F4A42-1 | 5M/T<br>4A/T | -<br>-                        |
| Lancer<br>Station<br>Wagon | CB5W                       | 4G93-0<br>(1,8)  | -        | Enkel    | -                               | -                        | MPI                        | F5M22-2<br>F4A22-2 | 5M/T<br>4A/T | -<br>-                        |
| Lancer                     | CK2A                       | 4G15-3<br>(1,5)  | -        | Enkel    | -                               | -                        | MPI                        | F5M42-1<br>F4A42-1 | 5M/T<br>4A/T | -<br>-                        |
|                            | CK5A                       | 4G93-3<br>(1,8)  | -        | Enkel    | -                               | -                        | MPI                        | F5M41-1<br>F4A41-1 | 5M/T<br>4A/T | -<br>-                        |
| Space<br>Wagon             | N84W                       | 4G64-2<br>(2,4)  | x        | Enkel    | x                               | -                        | MPI                        | F5M42-2<br>F4A42-2 | 5M/T<br>4A/T | -<br>-                        |
| Pajero                     | V45W                       | 6G74-8<br>(3,5)  | -        | Dubbel   | x                               | -                        | MPI                        | V5M31-5<br>V4AW3-B | 5M/T<br>4A/T | x<br>x                        |
|                            | V46W                       | 4M40<br>(2,8)    | x        | Enkel    | -                               | x                        | Diesel<br>S-RGS            | V5M31-5            | 5M/T         | x                             |
| L200                       | K65T                       | 4G64-2<br>(2,4)  | x        | Enkel    | x                               | -                        | MPI                        | R5M21-5<br>R4AW2-6 | 5M/T<br>4A/T | -<br>-                        |
|                            | K66T                       | 6G72-8<br>(3,0)  | -        | Dubbel   | x                               | -                        | MPI                        | R5M31-4            | 5M/T         | -                             |
|                            | K67T                       | 4M40<br>(2,8)    | x        | Enkel    | -                               | -                        | Diesel<br>S-RGS            | R5M21-5            | 5M/T         | -                             |
|                            | K76T                       | 6G72-8<br>(3,0)  | -        | Dubbel   | x                               | -                        | MPI                        | V5MT1-4<br>V4AW3-6 | 5M/T<br>4A/T | x<br>x                        |
|                            | K77T                       | 4M40<br>(2,8)    | x        | Enkel    | -                               | -                        | Diesel<br>S-RGS            | V5M21-9            | 5M/T         | x                             |
| Challenger                 | K96W                       | 6G72-8<br>(3,0)  | -        | Dubbel   | x                               | -                        | MPI                        | V5MT1-4<br>V4AW3-6 | 5M/T<br>4A/T | x<br>x                        |

## 2000 modellen voor Australië

| Voertuig-<br>model | Voertuig<br>model-<br>code | Motor            |          |          |                                 |                          | Brand-<br>stof-<br>systeem | Versnelingsbak     |              |                               |
|--------------------|----------------------------|------------------|----------|----------|---------------------------------|--------------------------|----------------------------|--------------------|--------------|-------------------------------|
|                    |                            | Model<br>(liter) | Balansas | Nokkenas | Hydrau-<br>lische<br>klepstoter | Turbo<br>compres-<br>sor |                            | Model              | Type         | Vierwiel-<br>aandrij-<br>ving |
| L300               | P03V                       | 4G63-A<br>(2,0)  | ×        | Enkel    | ×                               | –                        | CARB                       | R5M21-2<br>R4AW2-8 | 5M/T<br>4A/T | –<br>–                        |
|                    | P03W                       | 4G63-6<br>(2,0)  | ×        | Enkel    | ×                               | –                        | MPI                        | R5M21-2<br>R4AW2-8 | 5M/T<br>4A/T | –<br>–                        |
|                    | P05V<br>P15V<br>P15W       | 4D56-4<br>(2,5)  | ×        | Enkel    | –                               | ×                        | Diesel<br>S-RGS            | R5M21-2            | 5M/T         | –                             |
|                    | P15V                       | 4G56-2<br>(2,5)  | ×        | Enkel    | –                               | –                        | Diesel<br>S-RGS            | R5M21-2            | 5M/T         | –                             |
|                    | P14V                       | 4G64-2<br>(2,4)  | ×        | Enkel    | ×                               | –                        | MPI                        | R5M21-2<br>R4AW2-8 | 5M/T<br>4A/T | –<br>–                        |
|                    | P04V<br>P14W               | 4G64-2<br>(2,4)  | ×        | Enkel    | ×                               | –                        | MPI                        | R5M21-2            | 5M/T         | –                             |
| L400               | PB4V                       | 4G64-2<br>(2,4)  | ×        | Enkel    | ×                               | –                        | MPI                        | R5M21-7<br>R4AW2-5 | 5M/T<br>4A/T | –<br>–                        |
|                    | PA3W                       | 4G63-6<br>(2,0)  | ×        | Enkel    | ×                               | –                        | MPI                        | R5M21-7<br>R4AW2-5 | 5M/T<br>4A/T | –<br>–                        |
|                    | PA4W                       | 4G64-2<br>(2,4)  | ×        | Enkel    | ×                               | –                        | MPI                        | R4AW2-5            | 4A/T         | –                             |

2001 modellen voor Europa

| Voertuig-<br>model | Voertuig<br>model-<br>code | Motor            |          |          |                                 |                          | Brand-<br>stof-<br>systeem | Versnelingsbak     |              |                               |
|--------------------|----------------------------|------------------|----------|----------|---------------------------------|--------------------------|----------------------------|--------------------|--------------|-------------------------------|
|                    |                            | Model<br>(liter) | Balansas | Nokkenas | Hydrau-<br>lische<br>klepstoter | Turbo<br>compres-<br>sor |                            | Model              | Type         | Vierwiel-<br>aandrij-<br>ving |
| Colt               | CJ1A                       | 4G13-6<br>(1,3)  | -        | Enkel    | x                               | -                        | MPI                        | F5M41-1            | 5M/T         | -                             |
|                    | CJ4A                       | 4G92-3<br>(1,6)  | -        | Enkel    | x                               | -                        | MPI                        | F5M41-1<br>F4A41-1 | 5M/T<br>4A/T | -<br>-                        |
|                    | CK1A                       | 4G13-3<br>(1,3)  | -        | Enkel    | -                               | -                        | MPI                        | F5M41-1<br>F4A41-1 | 5M/T<br>4A/T | -<br>-                        |
| Space<br>Star      | DG1A                       | 4G13-6<br>(1,3)  | -        | Enkel    | x                               | -                        | MPI                        | JB3-241            | 5M/T         | -                             |
|                    | DG4A                       | F9QT-0<br>(1,9)  | -        | Enkel    | -                               | -                        | Diesel<br>S-RGS            | F5MV1-1            | 5M/T         | -                             |
|                    | DG5A                       | 4G93-G<br>(1,8)  | -        | Dubbel   | x                               | -                        | GDI                        | F5M42-1            | 5M/T         | -                             |
| Carisma            | DA1A                       | 4G92-2<br>(1,6)  | -        | Enkel    | x                               | -                        | MPI                        | JB3-242<br>F4A41-1 | 5M/T<br>4A/T | -<br>-                        |
|                    | DA2A                       | 4G93-G<br>(1,8)  | -        | Dubbel   | x                               | -                        | GDI                        | F5M42-1<br>F4A42-1 | 5M/T<br>4A/T | -<br>-                        |
|                    | DA5A                       | F9QT-0<br>(1,9)  | -        | Enkel    | -                               | x                        | Diesel<br>S-RGS            | F5MV1-L            | 5M/T         | -                             |
|                    |                            | F9QT-1<br>(1,9)  | -        | Enkel    | -                               | x                        | Diesel<br>S-RGS            | F5MV1-L            | 5M/T         | -                             |
| Space<br>Runner    | N63W                       | 4G63-F<br>(2,0)  | x        | Enkel    | x                               | -                        | MPI                        | F5M42-2<br>F4A42-1 | 5M/T<br>4A/T | -<br>-                        |
|                    | N64W                       | 4G64-4<br>(2,4)  | x        | Dubbel   | x                               | -                        | GDI                        | F5M42-2<br>F4A42-2 | 5M/T<br>4A/T | -<br>-                        |
| Space<br>Wagon     | N83W                       | 4G63-F<br>(2,0)  | x        | Enkel    | x                               | -                        | MPI                        | F5M42-2            | 5M/T         | -                             |
|                    | N84W                       | 4G64-4<br>(2,4)  | x        | Dubbel   | x                               | -                        | GDI                        | F5M42-2<br>F4A42-2 | 5M/T<br>4A/T | -<br>-                        |
|                    | N94W                       | 4G64-4<br>(2,4)  | x        | Dubbel   | x                               | -                        | GDI                        | W5M42-1            | 5M/T         | x                             |

## 2001 modellen voor Europa

| Voertuig-<br>model | Voertuig<br>model-<br>code | Motor            |          |            |                                 |                          | Brand-<br>stof-<br>systeem | Versnelingsbak     |              |                               |
|--------------------|----------------------------|------------------|----------|------------|---------------------------------|--------------------------|----------------------------|--------------------|--------------|-------------------------------|
|                    |                            | Model<br>(liter) | Balansas | Nokkenas   | Hydrau-<br>lische<br>klepstoter | Turbo<br>compres-<br>sor |                            | Model              | Type         | Vierwiel-<br>aandrij-<br>ving |
| Galant             | EA2A<br>EA2W               | 4G63-6<br>(2,0)  | ×        | Enkel      | ×                               | –                        | MPI                        | F5M42-2<br>F4A42-1 | 5M/T<br>4A/T | –<br>–                        |
|                    | EA3A<br>EA3W               | 4G64-4<br>(2,4)  | ×        | Dubbel     | ×                               | –                        | GDI                        | F5M42-2<br>F4A42-2 | 5M/T<br>4A/T | –<br>–                        |
|                    | EA5A<br>EA5W               | 6A13-4<br>(2,5)  | –        | Dubbel     | ×                               | –                        | MPI                        | F5M42-2<br>F4A42-2 | 5M/T<br>4A/T | –<br>–                        |
| Pajero/<br>Montero | V23C                       | 6G72-8<br>(3,0)  | –        | Dubbel     | ×                               | –                        | MPI                        | V5MT1-6<br>V4AW3-B | 5M/T<br>4A/T | ×                             |
|                    | V24C<br>V24W<br>V44W       | 4D56-4<br>(2,5)  | ×        | Enkel      | –                               | ×                        | Diesel<br>S-RGS            | V5MT1-6            | 5M/T         | ×                             |
|                    | V64W<br>V74W               | 4D56-4<br>(2,5)  | ×        | Enkel      | –                               | ×                        | Diesel<br>S-RGS            | V5MT1-8<br>V5M31-6 | 5M/T<br>5M/T | ×                             |
|                    | V65W<br>V75W               | 6G74-B<br>(3,5)  | –        | Dubbel × 2 | ×                               | –                        | GDI                        | V5M31-6<br>V5A51-7 | 5M/T<br>5A/T | ×                             |
|                    | V68W<br>V78W               | 4M41<br>(3,2)    | ×        | Dubbel     | –                               | ×                        | Diesel<br>S-RGS            | V5M31-6<br>V5A51-7 | 5M/T<br>5A/T | ×                             |
| L200               | K62T                       | 4G63-6<br>(2,0)  | ×        | Enkel      | ×                               | –                        | MPI                        | R5M21-5<br>R4AW2-6 | 5M/T<br>4A/T | –<br>–                        |
|                    | K64T                       | 4D56-4<br>(2,5)  | ×        | Enkel      | –                               | –                        | Diesel<br>S-RGS            | R5M21-5            | 5M/T         | –                             |
|                    | K74T                       | 4D56-4<br>(2,5)  | ×        | Enkel      | –                               | ×                        | Diesel<br>S-RGS            | V5MT1-4<br>V4AW2-6 | 5M/T<br>4A/T | ×                             |
|                    | K75T                       | 4G64-2<br>(2,4)  | ×        | Enkel      | ×                               | –                        | MPI                        | V5M21-9            | 5M/T         | ×                             |
| Pajero<br>Sport    | K94W                       | 4D56-4<br>(2,5)  | ×        | Enkel      | –                               | ×                        | Diesel<br>S-RGS            | V5MT1-B            | 5M/T         | ×                             |
|                    | K96W                       | 6G72-8<br>(3,0)  | –        | Dubbel     | ×                               | –                        | MPI                        | V5MT1-B<br>V4A51-5 | 5M/T<br>4A/T | ×                             |
| Pajero<br>Pinin    | H67W<br>H77W               | 4G94-H<br>(2,0)  | –        | Dubbel     | ×                               | –                        | GDI                        | V5M21-A<br>V4AW4-D | 5M/T<br>4A/T | ×                             |

## 2001 modellen voor algemene export

| Voertuig-<br>model         | Voertuig<br>model-<br>code | Motor            |          |          |                                 |                          | Brand-<br>stof-<br>systeem | Versnelingsbak     |              |                               |
|----------------------------|----------------------------|------------------|----------|----------|---------------------------------|--------------------------|----------------------------|--------------------|--------------|-------------------------------|
|                            |                            | Model<br>(liter) | Balansas | Nokkenas | Hydrau-<br>lische<br>klepstoter | Turbo<br>compres-<br>sor |                            | Model              | Type         | Vierwiel-<br>aandrij-<br>ving |
| Colt                       | CJ1A                       | 4G13-5<br>(1,3)  | -        | Enkel    | -                               | -                        | CARB                       | F5M41-1            | 5M/T         | -                             |
|                            | CJ2A                       | 4G15-5<br>(1,5)  | -        | Enkel    | -                               | -                        | CARB                       | F5M41-1<br>F4A41-1 | 5M/T<br>4A/T | -<br>-                        |
|                            | CJ4A                       | 4G92-3<br>(1,6)  | -        | Enkel    | -                               | -                        | MPI                        | F5M41-1<br>F4A41-1 | 5M/T<br>4A/T | -<br>-                        |
| Lancer                     | CS1A                       | 4G13-6<br>(1,3)  | -        | Enkel    | -                               | -                        | MPI                        | F5M41-1<br>F4A41-1 | 5M/T<br>4A/T | -<br>-                        |
|                            |                            | 4G13-7<br>(1,3)  | -        | Enkel    | -                               | -                        | CARB                       | F5M41-1<br>F4A41-1 | 5M/T<br>4A/T | -<br>-                        |
|                            | CS2A                       | 4G15-8<br>(1,5)  | -        | Dubbel   | x                               | -                        | GDI                        | F1C1A-1            | CVT          | -                             |
|                            | CS3A                       | 4G18-6<br>(1,8)  | -        | Enkel    | -                               | -                        | MPI                        | F5M41-1<br>F1C1A-1 | 5M/T<br>CVT  | -<br>-                        |
|                            |                            | 4G18-7<br>(1,8)  | -        | Enkel    | -                               | -                        | CARB                       | F5M41-1<br>F4A41-1 | 5M/T<br>4A/T | -<br>-                        |
| CS5A                       | 4G93-G<br>(1,8)            | -                | Dubbel   | x        | -                               | GDI                      | F1C1A-2                    | CVT                | -            |                               |
| Lancer<br>Station<br>Wagon | CB1W                       | 4G13-2<br>(1,3)  | -        | Enkel    | -                               | -                        | CARB                       | F5M21-1<br>F3A21-2 | 5M/T<br>3A/T | -<br>-                        |
|                            | CB2W                       | 4G15-2<br>(1,5)  | -        | Enkel    | -                               | -                        | CARB                       | F5M21-1<br>F3A21-2 | 5M/T<br>3A/T | -<br>-                        |
|                            | CB4W                       | 4G92-0<br>(1,6)  | -        | Enkel    | -                               | -                        | MPI                        | F5M22-2<br>F4A22-2 | 5M/T<br>4A/T | -<br>-                        |
| Mirage<br>Dingo            | CQ2A                       | 4G15-8<br>(1,5)  | -        | Dubbel   | x                               | -                        | GDI                        | F4A41-1            | 4A/T         | -                             |
| Space<br>Wagon             | N84W                       | 4G64-2<br>(2,4)  | x        | Enkel    | x                               | -                        | MPI                        | F5M42-2<br>F4A42-2 | 5M/T<br>4A/T | -<br>-                        |
|                            |                            | 4G64-4<br>(2,4)  | x        | Dubbel   | x                               | -                        | GDI                        | F4A42-2            | 4A/T         | -                             |

## 2001 modellen voor algemene export

| Voertuig-<br>model | Voertuig<br>model-<br>code | Motor            |          |          |                                 |                          | Brand-<br>stof-<br>systeem | Versnelingsbak                |                      |                               |
|--------------------|----------------------------|------------------|----------|----------|---------------------------------|--------------------------|----------------------------|-------------------------------|----------------------|-------------------------------|
|                    |                            | Model<br>(liter) | Balansas | Nokkenas | Hydrau-<br>lische<br>klepstoter | Turbo<br>compres-<br>sor |                            | Model                         | Type                 | Vierwiel-<br>aandrij-<br>ving |
| Galant             | EA1A                       | 4G93-9<br>(1,8)  | -        | Enkel    | -                               | -                        | CARB                       | F5M42-1<br>F4A42-1            | 5M/T<br>4A/T         | -<br>-                        |
|                    | EA2A                       | 4G63-E<br>(2,0)  | x        | Enkel    | x                               | -                        | CARB                       | F5M42-1<br>F4A42-1            | 5M/T<br>4A/T         | -<br>-                        |
|                    | EA2A<br>EA2W               | 4G63-6<br>(2,0)  | x        | Enkel    | x                               | -                        | MPI                        | F5M42-1<br>F4A42-1            | 5M/T<br>4A/T         | -<br>-                        |
|                    | EA3A                       | 4G64-6<br>(2,4)  | x        | Dubbel   | x                               | -                        | GDI                        | F5A42-2                       | 5A/T                 | -                             |
|                    | EA5A                       | 6A13-4<br>(2,5)  | -        | Dubbel   | x                               | -                        | MPI                        | F5M42-2<br>F4A42-2            | 5M/T<br>4A/T         | -<br>-                        |
|                    | EA6A                       | 4D68-2<br>(2,0)  | x        | Enkel    | -                               | x                        | Diesel<br>S-RGS            | F5M42-2                       | 5M/T                 | -                             |
|                    | EA7A                       | 4G94-G<br>(2,0)  | -        | Dubbel   | x                               | -                        | GDI                        | F4A42-1                       | 4A/T                 | -                             |
| Pajero/<br>Montero | V11V<br>V31V               | 4G64-6<br>(2,4)  | x        | Enkel    | -                               | -                        | CARB                       | V5M21-6                       | 5M/T                 | x                             |
|                    | V13V<br>V33V               | 6G72-1<br>(3,0)  | -        | Dubbel   | x                               | -                        | MPI                        | V5MT1-6<br>V4AW2-7            | 5M/T<br>4A/T         | x<br>x                        |
|                    | V14C                       | 4D56-4<br>(2,5)  | x        | Enkel    | -                               | -                        | Diesel<br>S-RGS            | V5M21-6                       | 5M/T                 | x                             |
|                    | V14V<br>V34V               | 4D56-4<br>(2,5)  | x        | Enkel    | -                               | -                        | Diesel<br>S-RGS            | V5M21-6                       | 5M/T                 | x                             |
|                    | V36V                       | 4M40<br>(2,8)    | x        | Enkel    | -                               | -                        | Diesel<br>S-RGS            | V5M21-6                       | 5M/T                 | x                             |
|                    | V63W<br>V73W               | 6G72-8<br>(3,0)  | -        | Dubbel   | x                               | -                        | MPI                        | V5MT1-8<br>V5M31-6<br>V4A51-7 | 5M/T<br>5M/T<br>4A/T | x<br>x<br>x                   |
|                    | V65W<br>V75W               | 6G74-8<br>(3,5)  | -        | Dubbel   | x                               | -                        | MPI                        | V5M31-6<br>V5A51-7            | 5M/T<br>5A/T         | x<br>x                        |
|                    |                            | 6G74-B<br>(3,5)  | -        | Vier     | x                               | -                        | GDI                        | V4A51-7<br>V5A51-7            | 4A/T<br>5A/T         | x<br>x                        |

## 2001 modellen voor algemene export

| Voertuig-<br>model | Voertuig<br>model-<br>code | Motor            |          |          |                                 |                          | Brand-<br>stof-<br>systeem | Versnelingsbak     |              |                               |   |
|--------------------|----------------------------|------------------|----------|----------|---------------------------------|--------------------------|----------------------------|--------------------|--------------|-------------------------------|---|
|                    |                            | Model<br>(liter) | Balansas | Nokkenas | Hydrau-<br>lische<br>klepstoter | Turbo<br>compres-<br>sor |                            | Model              | Type         | Vierwiel-<br>aandrij-<br>ving |   |
| Pajero/<br>Montero | V66W<br>V76W               | 4M40<br>(2,8)    | ×        | Enkel    | –                               | ×                        | Diesel<br>S-RGS            | V5M31-6<br>V4A51-7 | 5M/T<br>4A/T | ×                             | × |
|                    | V68W<br>V78W               | 4M41<br>(3,2)    | ×        | Dubbel   | –                               | ×                        | Diesel<br>S-RGS            | V5M31-6<br>V5A51-7 | 5M/T<br>5A/T | ×                             | × |
| L200               | K62T                       | 4G63-6<br>(2,0)  | ×        | Enkel    | ×                               | –                        | MPI                        | R5M21-5            | 5M/T         | –                             | – |
|                    |                            |                  | –        | Enkel    | ×                               | –                        | CARB                       | R5M21-5            | 5M/T         | –                             | – |
|                    | K64T                       | 4D56-3<br>(2,5)  | ×        | Enkel    | –                               | –                        | Diesel<br>S-RGS            | R5M21-5            | 5M/T         | –                             | – |
|                    |                            |                  | ×        | Enkel    | –                               | –                        | Diesel<br>S-RGS            | R5M21-5            | 5M/T         | –                             | – |
|                    | K65T                       | 4G64-2<br>(2,4)  | ×        | Enkel    | ×                               | –                        | MPI                        | R5M21-5            | 5M/T         | –                             | – |
|                    | K67T                       | 4M40<br>(2,8)    | ×        | Enkel    | –                               | –                        | Diesel<br>S-RGS            | R5M21-5<br>R4AW2-6 | 5M/T<br>4A/T | –                             | – |
|                    | K72T                       | 4G63-6<br>(2,0)  | –        | Enkel    | ×                               | –                        | CARB                       | V5M21-9            | 5M/T         | ×                             | × |
|                    |                            |                  | –        | Enkel    | ×                               | –                        | CARB                       | V5M21-9            | 5M/T         | ×                             | × |
|                    | K74T                       | 4D56-3<br>(2,5)  | ×        | Enkel    | –                               | ×                        | Diesel<br>S-RGS            | V5MT1-4            | 5M/T         | ×                             | × |
|                    |                            |                  | ×        | Enkel    | –                               | –                        | Diesel<br>S-RGS            | V5M21-9            | 5M/T         | ×                             | × |
|                    |                            | 4D56-4<br>(2,5)  | ×        | Enkel    | –                               | –                        | Diesel<br>S-RGS            | V5M21-9            | 5M/T         | ×                             | × |
|                    |                            | ×                | Enkel    | –        | ×                               | Diesel<br>S-RGS          | V5MT1-4                    | 5M/T               | ×            | ×                             |   |
|                    | K75T                       | 4G64-2<br>(2,4)  | ×        | Enkel    | ×                               | –                        | MPI                        | V5M21-9            | 5M/T         | ×                             | × |
|                    | K77T                       | 4M40<br>(2,8)    | ×        | Enkel    | –                               | –                        | Diesel<br>S-RGS            | V5M21-9            | 5M/T         | ×                             | × |



## 2001 modellen voor algemene export

| Voertuig-<br>model | Voertuig<br>model-<br>code | Motor            |          |          |                                 |                          | Brand-<br>stof-<br>systeem | Versnelingsbak     |              |                               |
|--------------------|----------------------------|------------------|----------|----------|---------------------------------|--------------------------|----------------------------|--------------------|--------------|-------------------------------|
|                    |                            | Model<br>(liter) | Balansas | Nokkenas | Hydrau-<br>lische<br>klepstoter | Turbo<br>compres-<br>sor |                            | Model              | Type         | Vierwiel-<br>aandrij-<br>ving |
| Pajero<br>io       | H65W                       | 4G18-9<br>(1,8)  | –        | Enkel    | –                               | –                        | MPI                        | V5M21-A<br>V4AW4-D | 5M/T<br>4A/T | ×<br>×                        |
|                    | H66W<br>H76W               | 4G93-H<br>(1,8)  | –        | Dubbel   | ×                               | –                        | GDI                        | V5M21-A<br>V4AW4-D | 5M/T<br>4A/T | ×<br>×                        |
|                    | H76W                       | 4G93-D<br>(1,8)  | –        | Enkel    | –                               | –                        | MPI                        | V5M21-A<br>V4AW4-D | 5M/T<br>4A/T | ×<br>×                        |
| Challenger         | K86W                       | 6G72-8<br>(3,0)  | –        | Dubbel   | ×                               | –                        | MPI                        | R5M31-B<br>R4A51-5 | 5M/T<br>4A/T | –<br>–                        |
|                    | K96W                       | 6G72-8<br>(3,0)  | –        | Dubbel   | ×                               | –                        | MPI                        | V5MT1-B<br>V4A51-5 | 5M/T<br>4A/T | ×<br>×                        |
|                    | K97W                       | 4M40<br>(2,8)    | ×        | Enkel    | –                               | ×                        | Diesel<br>S-RGS            | V5M31-B<br>V4A51-5 | 5M/T<br>4A/T | ×<br>×                        |
| Sigma              | F36A                       | 6G72-5<br>(3,0)  | –        | Dubbel   | ×                               | –                        | MPI                        | F4A51-2            | 4A/T         | –                             |

2001 modellen voor Australië

| Voertuig-<br>model         | Voertuig<br>model-<br>code | Motor            |          |          |                                 |                          | Brand-<br>stof-<br>systeem | Versnelingsbak     |              |                               |
|----------------------------|----------------------------|------------------|----------|----------|---------------------------------|--------------------------|----------------------------|--------------------|--------------|-------------------------------|
|                            |                            | Model<br>(liter) | Balansas | Nokkenas | Hydrau-<br>lische<br>klepstoter | Turbo<br>compres-<br>sor |                            | Model              | Type         | Vierwiel-<br>aandrij-<br>ving |
| Colt                       | CJ2A                       | 4G15-3<br>(1,5)  | –        | Enkel    | –                               | –                        | MPI                        | F5M41-1<br>F4A41-1 | 5M/T<br>4A/T | –<br>–                        |
|                            | CJ5A                       | 4G93-3<br>(1,8)  | –        | Enkel    | –                               | –                        | MPI                        | F5M42-1<br>F4A42-1 | 5M/T<br>4A/T | –<br>–                        |
| Lancer<br>Station<br>Wagon | CB5W                       | 4G93-0<br>(1,8)  | –        | Enkel    | –                               | –                        | MPI                        | F5M22-2<br>F4A22-2 | 5M/T<br>4A/T | –<br>–                        |
| Lancer                     | CK2A                       | 4G15-3<br>(1,5)  | –        | Enkel    | –                               | –                        | MPI                        | F5M41-1<br>F4A41-1 | 5M/T<br>4A/T | –<br>–                        |
|                            | CK5A                       | 4G93-3<br>(1,8)  | –        | Enkel    | –                               | –                        | MPI                        | F5M42-1<br>F4A42-1 | 5M/T<br>4A/T | –<br>–                        |
| Space<br>Wagon             | N84W                       | 4G64-2<br>(2,4)  | ×        | Enkel    | ×                               | –                        | MPI                        | F5M42-2<br>F4A42-2 | 5M/T<br>4A/T | –<br>–                        |
| Pajero/<br>Montero         | V75W                       | 6G74-8<br>(3,5)  | –        | Dubbel   | ×                               | –                        | MPI                        | V5M31-6<br>V5A51-7 | 5M/T<br>5A/T | ×                             |
|                            | V76W                       | 4M40<br>(2,8)    | ×        | Enkel    | –                               | ×                        | Diesel<br>S-RGS            | V5M31-6            | 5M/T         | ×                             |
| Pajero<br>io               | H65W                       | 4G18-9<br>(1,8)  | –        | Enkel    | –                               | –                        | MPI                        | V5M21-A            | 5M/T         | ×                             |
|                            | H76W                       | 4G93-D<br>(1,8)  | –        | Enkel    | –                               | –                        | MPI                        | V5M21-A<br>V4AW4-D | 5M/T<br>4A/T | ×                             |
| L200                       | K65T                       | 4G64-2<br>(2,4)  | ×        | Enkel    | ×                               | –                        | MPI                        | R5M21-5            | 5M/T         | –                             |
|                            | K66T                       | 6G72-8<br>(3,0)  | –        | Dubbel   | ×                               | –                        | MPI                        | R5M31-4<br>R4A51-4 | 5M/T<br>4A/T | –<br>–                        |
|                            | K76T                       | 6G72-8<br>(3,0)  | –        | Dubbel   | ×                               | –                        | MPI                        | V5MT1-4<br>V4A51-4 | 5M/T<br>4A/T | ×                             |
|                            | K77T                       | 4M40<br>(2,8)    | ×        | Enkel    | –                               | –                        | Diesel<br>S-RGS            | V5M21-9            | 5M/T         | ×                             |
| Challenger K96W            |                            | 6G72-8<br>(3,0)  | –        | Dubbel   | ×                               | –                        | MPI                        | V5MT1-4<br>V4A51-4 | 5M/T<br>4A/T | ×                             |

## 2001 modellen voor Australië

| Voertuig-<br>model | Voertuig<br>model-<br>code | Motor            |          |          |                                 |                          | Brand-<br>stof-<br>systeem | Versnelingsbak                |                      |                               |
|--------------------|----------------------------|------------------|----------|----------|---------------------------------|--------------------------|----------------------------|-------------------------------|----------------------|-------------------------------|
|                    |                            | Model<br>(liter) | Balansas | Nokkenas | Hydrau-<br>lische<br>klepstoter | Turbo<br>compres-<br>sor |                            | Model                         | Type                 | Vierwiel-<br>aandrij-<br>ving |
| Sigma              | F36A                       | 6G72-5<br>(3,0)  | –        | Dubbel   | ×                               | –                        | MPI                        | F5M51-1<br>F4A51-2            | 5M/T<br>4A/T         | –<br>–                        |
|                    | F38A                       | 6G74-5<br>(3,5)  | –        | Dubbel   | ×                               | –                        | MPI                        | F5M51-1<br>F4A51-2<br>F5A51-2 | 5M/T<br>4A/T<br>5A/T | –<br>–<br>–                   |
| Magna              | F36W                       | 6G72-5<br>(3,0)  | –        | Dubbel   | ×                               | –                        | MPI                        | F5M51-1<br>F4A51-2            | 5M/T<br>4A/T         | –<br>–                        |
|                    | F38W                       | 6G74-5<br>(3,5)  | –        | Dubbel   | ×                               | –                        | MPI                        | F5M51-1<br>F4A51-2            | 5M/T<br>4A/T         | –<br>–                        |

2002 modellen voor Europa

| Voertuig-<br>model | Voertuig<br>model-<br>code | Motor            |          |          |                                 |                          | Brand-<br>stof-<br>systeem | Versnelingsbak     |              |                               |
|--------------------|----------------------------|------------------|----------|----------|---------------------------------|--------------------------|----------------------------|--------------------|--------------|-------------------------------|
|                    |                            | Model<br>(liter) | Balansas | Nokkenas | Hydrau-<br>lische<br>klepstoter | Turbo<br>compres-<br>sor |                            | Model              | Type         | Vierwiel-<br>aandrij-<br>ving |
| Colt               | CJ1A                       | 4G13-6<br>(1,3)  | –        | Enkel    | ×                               | –                        | MPI                        | F5M41-1            | 5M/T         | –                             |
|                    | CJ4A                       | 4G92-3<br>(1,6)  | –        | Enkel    | ×                               | –                        | MPI                        | F5M41-1<br>F4A41-1 | 5M/T<br>4A/T | –<br>–                        |
| Space<br>Star      | DG1A                       | 4G13-6<br>(1,3)  | –        | Enkel    | ×                               | –                        | MPI                        | JB3-241            | 5M/T         | –                             |
|                    | DG3A                       | 4G18-6<br>(1,6)  | –        | Enkel    | ×                               | –                        | MPI                        | JB3-244<br>F4A41-1 | 5M/T<br>4A/T | –<br>–                        |
|                    | DG4A                       | F9QT-0<br>(1,9)  | –        | Enkel    | –                               | –                        | Diesel<br>S-RGS            | F5MV1-L            | 5M/T         | –                             |
|                    | DG5A                       | 4G93-G<br>(1,8)  | –        | Dubbel   | ×                               | –                        | GDI                        | F5M42-1<br>F4A42-1 | 5M/T<br>4A/T | –<br>–                        |
| Carisma            | DA1A                       | 4G92-2<br>(1,6)  | –        | Enkel    | ×                               | –                        | MPI                        | JB3-243<br>F4A41-1 | 5M/T<br>4A/T | –<br>–                        |
|                    | DA2A                       | 4G93-G<br>(1,8)  | –        | Dubbel   | ×                               | –                        | GDI                        | F5M42-1<br>F4A42-1 | 5M/T<br>4A/T | –<br>–                        |
|                    | DA5A                       | F9QT-0<br>(1,9)  | –        | Enkel    | –                               | ×                        | Diesel<br>S-RGS            | F5MV1-L            | 5M/T         | –                             |
|                    |                            | F9QT-1<br>(1,9)  | –        | Enkel    | –                               | ×                        | Diesel<br>S-RGS            | F5MV1-L            | 5M/T         | –                             |
|                    | DA6A                       | 4G13-6<br>(1,3)  | –        | Enkel    | ×                               | –                        | MPI                        | JB3-308            | 5M/T         | –                             |
| Space<br>Wagon     | N83W                       | 4G63-F<br>(2,0)  | ×        | Enkel    | ×                               | –                        | MPI                        | F5M42-2            | 5M/T         | –                             |
|                    | N84W                       | 4G64-4<br>(2,4)  | ×        | Dubbel   | ×                               | –                        | GDI                        | F5M42-2<br>F4A42-2 | 5M/T<br>4A/T | –<br>–                        |
|                    | N94W                       | 4G64-4<br>(2,4)  | ×        | Dubbel   | ×                               | –                        | GDI                        | W5M42-1            | 5M/T         | ×                             |

## 2002 modellen voor Europa

| Voertuig-<br>model | Voertuig<br>model-<br>code | Motor            |          |            |                                 |                          | Brand-<br>stof-<br>systeem | Versnelingsbak     |              |                               |
|--------------------|----------------------------|------------------|----------|------------|---------------------------------|--------------------------|----------------------------|--------------------|--------------|-------------------------------|
|                    |                            | Model<br>(liter) | Balansas | Nokkenas   | Hydrau-<br>lische<br>klepstoter | Turbo<br>compres-<br>sor |                            | Model              | Type         | Vierwiel-<br>aandrij-<br>ving |
| Pajero/<br>Montero | V24W<br>V44W               | 4D56-5<br>(2,5)  | ×        | Enkel      | –                               | ×                        | Diesel<br>S-RGS            | V5MT1-6            | 5M/T         | ×                             |
|                    | V64W<br>V74W               | 4D56-5<br>(2,5)  | ×        | Enkel      | –                               | ×                        | Diesel<br>S-RGS            | V5MT1-8<br>V5M31-6 | 5M/T<br>5M/T | ×                             |
|                    | V65W<br>V75W               | 6G74-B<br>(3,5)  | –        | Dubbel × 2 | ×                               | –                        | GDI                        | V5M31-6<br>V5A51-7 | 5M/T<br>5A/T | ×                             |
|                    | V68W<br>V78W               | 4M41<br>(3,2)    | ×        | Dubbel     | –                               | ×                        | Diesel<br>S-RGS            | V5M31-6<br>V5A51-7 | 5M/T<br>5A/T | ×                             |
| L200               | K64T                       | 4D56-4<br>(2,5)  | ×        | Enkel      | –                               | –                        | Diesel<br>S-RGS            | R5M21-5            | 5M/T         | –                             |
|                    |                            | 4D56-5<br>(2,5)  | ×        | Enkel      | –                               | ×                        | Diesel<br>S-RGS            | R5M21-5<br>R4AW2-6 | 5M/T<br>4A/T | –                             |
|                    | K74T                       | 4D56-4<br>(2,5)  | ×        | Enkel      | –                               | ×                        | Diesel<br>S-RGS            | V5MT1-4<br>V4AW2-6 | 5M/T<br>4A/T | ×                             |
|                    |                            | 4D56-5<br>(2,5)  | ×        | Enkel      | –                               | ×                        | Diesel<br>S-RGS            | V5MT1-4<br>V4AW2-6 | 5M/T<br>4A/T | ×                             |
|                    | K75T                       | 4G64-2<br>(2,4)  | ×        | Enkel      | ×                               | –                        | MPI                        | V5M21-9            | 5M/T         | ×                             |
| Pajero<br>Sport    | K94W                       | 4D56-4<br>(2,5)  | ×        | Enkel      | –                               | ×                        | Diesel<br>S-RGS            | V5MT1-B            | 5M/T         | ×                             |
|                    |                            | 4D56-5<br>(2,5)  | ×        | Enkel      | –                               | ×                        | Diesel<br>S-RGS            | V5MT1-D            | 5M/T         | ×                             |
|                    | K96W                       | 6G72-8<br>(3,0)  | –        | Dubbel     | ×                               | –                        | MPI                        | V5MT1-D<br>V4A51-5 | 5M/T<br>4A/T | ×                             |
| Pajero<br>Pinin    | H66W<br>H76W               | 4G93-D<br>(1,8)  | –        | Enkel      | ×                               | –                        | MPI                        | V5M21-A<br>V4AW4-D | 5M/T<br>4A/T | ×                             |
|                    | H67W<br>H77W               | 4G94-H<br>(2,0)  | –        | Dubbel     | ×                               | –                        | GDI                        | V5M21-A<br>V4AW4-D | 5M/T<br>4A/T | ×                             |

## 2002 modellen voor Europa

| Voertuig-<br>model | Voertuig<br>model-<br>code | Motor            |          |          |                                 |                          | Brand-<br>stof-<br>systeem | Versnelingsbak     |              |                               |
|--------------------|----------------------------|------------------|----------|----------|---------------------------------|--------------------------|----------------------------|--------------------|--------------|-------------------------------|
|                    |                            | Model<br>(liter) | Balansas | Nokkenas | Hydrau-<br>lische<br>klepstoter | Turbo<br>compres-<br>sor |                            | Model              | Type         | Vierwiel-<br>aandrij-<br>ving |
| L300               | P03V<br>P13V               | 4G63-6<br>(2,0)  | ×        | Enkel    | ×                               | -                        | MPI                        | R5M21-2            | 5M/T         | -                             |
|                    | P05V<br>P15V               | 4D56-4<br>(2,5)  | ×        | Enkel    | -                               | -                        | Diesel<br>S-RGS            | R5M21-2            | 5M/T         | -                             |
|                    | P45V                       | 4D56-4<br>(2,5)  | ×        | Enkel    | -                               | ×                        | Diesel<br>S-RGS            | V5M21-2            | 5M/T         | ×                             |
| L400               | PA3V<br>PB3V               | 4G63-6<br>(2,0)  | ×        | Enkel    | ×                               | -                        | MPI                        | R5M21-7            | 5M/T         | -                             |
|                    | PA5V<br>PB5V               | 4D56-4<br>(2,5)  | ×        | Enkel    | -                               | ×                        | Diesel<br>S-RGS            | R5M21-7            | 5M/T         | -                             |
|                    | PD4V                       | 4G64-2<br>(2,4)  | ×        | Enkel    | ×                               | -                        | MPI                        | V5M21-7            | 5M/T         | ×                             |
|                    | PD5V                       | 4D56-4<br>(2,5)  | ×        | Enkel    | -                               | ×                        | Diesel<br>S-RGS            | V5M21-7            | 5M/T         | ×                             |
| Space<br>Gear      | PA3W                       | 4G63-6<br>(2,0)  | ×        | Enkel    | ×                               | -                        | MPI                        | R5M21-7            | 5M/T         | -                             |
|                    | PA4W                       | 4G64-2<br>(2,4)  | ×        | Enkel    | ×                               | -                        | MPI                        | R5M21-7<br>R4AW2-5 | 5M/T<br>4A/T | -<br>-                        |
|                    | PA5W                       | 4D56-4<br>(2,5)  | ×        | Enkel    | -                               | ×                        | Diesel<br>S-RGS            | R5M31-7            | 5M/T         | -                             |
|                    | PD4W                       | 4G64-2<br>(2,4)  | ×        | Enkel    | ×                               | -                        | MPI                        | V5M21-7            | 5M/T         | ×                             |
|                    | PD5W                       | 4D56-4<br>(2,5)  | ×        | Enkel    | -                               | ×                        | Diesel<br>S-RGS            | V5M31-7            | 5M/T         | ×                             |

## 2002 modellen voor algemene export

| Voertuig-<br>model         | Voertuig<br>model-<br>code | Motor            |          |          |                                 |                          | Brand-<br>stof-<br>systeem | Versnelingsbak     |              |                               |
|----------------------------|----------------------------|------------------|----------|----------|---------------------------------|--------------------------|----------------------------|--------------------|--------------|-------------------------------|
|                            |                            | Model<br>(liter) | Balansas | Nokkenas | Hydrau-<br>lische<br>klepstoter | Turbo<br>compres-<br>sor |                            | Model              | Type         | Vierwiel-<br>aandrij-<br>ving |
| Colt                       | CJ1A                       | 4G13-5<br>(1,3)  | –        | Enkel    | –                               | –                        | CARB                       | F5M41-1            | 5M/T         | –                             |
|                            | CJ2A                       | 4G15-5<br>(1,5)  | –        | Enkel    | –                               | –                        | CARB                       | F5M41-1<br>F4A41-1 | 5M/T<br>4A/T | –<br>–                        |
|                            | CJ4A                       | 4G92-3<br>(1,6)  | –        | Enkel    | –                               | –                        | MPI                        | F5M41-1<br>F4A41-1 | 5M/T<br>4A/T | –<br>–                        |
| Lancer                     | CS1A                       | 4G13-6<br>(1,3)  | –        | Enkel    | –                               | –                        | MPI                        | F5M41-1<br>F4A41-1 | 5M/T<br>4A/T | –<br>–                        |
|                            |                            | 4G13-7<br>(1,3)  | –        | Enkel    | –                               | –                        | CARB                       | F5M41-1<br>F4A41-1 | 5M/T<br>4A/T | –<br>–                        |
|                            | CS2A                       | 4G15-8<br>(1,5)  | –        | Dubbel   | ×                               | –                        | GDI                        | F1C1A-1            | CVT          | –                             |
|                            | CS3A                       | 4G18-6<br>(1,6)  | –        | Enkel    | –                               | –                        | MPI                        | F5M41-1<br>F1C1A-1 | 5M/T<br>CVT  | –<br>–                        |
|                            |                            | 4G18-7<br>(1,6)  | –        | Enkel    | –                               | –                        | CARB                       | F5M41-1<br>F4A41-1 | 5M/T<br>4A/T | –<br>–                        |
| CS5A                       | 4G93-G<br>(1,8)            | –                | Dubbel   | ×        | –                               | GDI                      | F1C1A-1                    | CVT                | –            |                               |
| Lancer<br>Station<br>Wagon | CB1W                       | 4G13-2<br>(1,3)  | –        | Enkel    | –                               | –                        | CARB                       | F5M21-1<br>F3A21-2 | 5M/T<br>3A/T | –<br>–                        |
|                            | CB2W                       | 4G15-2<br>(1,5)  | –        | Enkel    | –                               | –                        | CARB                       | F5M21-1<br>F3A21-2 | 5M/T<br>3A/T | –<br>–                        |
|                            | CB4W                       | 4G92-0<br>(1,6)  | –        | Enkel    | –                               | –                        | MPI                        | F5M22-2<br>F4A22-2 | 5M/T<br>4A/T | –<br>–                        |
| Space<br>Wagon             | N84W                       | 4G64-2<br>(2,4)  | ×        | Enkel    | ×                               | –                        | MPI                        | F5M42-2<br>F4A42-2 | 5M/T<br>4A/T | –<br>–                        |
|                            |                            | 4G64-4<br>(2,4)  | ×        | Dubbel   | ×                               | –                        | GDI                        | F4A42-2            | 4A/T         | –                             |
| Galant                     | EA1A                       | 4G93-9<br>(1,8)  | –        | Enkel    | –                               | –                        | CARB                       | F5M42-1<br>F4A42-1 | 5M/T<br>4A/T | –<br>–                        |
|                            | EA2A                       | 4G63-E<br>(2,0)  | ×        | Enkel    | ×                               | –                        | CARB                       | F5M42-1<br>F4A42-1 | 5M/T<br>4A/T | –<br>–                        |

2002 modellen voor algemene export

| Voertuig-<br>model | Voertuig<br>model-<br>code | Motor            |                 |            |                                 |                          | Brand-<br>stof-<br>systeem | Versnelingsbak |         |                               |
|--------------------|----------------------------|------------------|-----------------|------------|---------------------------------|--------------------------|----------------------------|----------------|---------|-------------------------------|
|                    |                            | Model<br>(liter) | Balansas        | Nokkenas   | Hydrau-<br>lische<br>klepstoter | Turbo<br>compres-<br>sor |                            | Model          | Type    | Vierwiel-<br>aandrij-<br>ving |
| Galant             | EA2A<br>EA2W               | 4G63-6<br>(2,0)  | ×               | Enkel      | ×                               | –                        | MPI                        | F5M42-1        | 5M/T    | –                             |
|                    |                            |                  | –               | Enkel      | –                               | F4A42-1                  |                            | 4A/T           | –       |                               |
|                    | EA5A                       | 6A13-4<br>(2,5)  | –               | Dubbel     | ×                               | –                        | MPI                        | F5M42-2        | 5M/T    | –                             |
|                    |                            |                  |                 |            |                                 |                          |                            | F4A42-2        | 4A/T    | –                             |
|                    | EA6A                       | 4D68-2<br>(2,0)  | ×               | Enkel      | –                               | ×                        | Diesel<br>S-RGS            | F5M42-2        | 5M/T    | –                             |
|                    | EA7A                       | 4G94-G<br>(2,0)  | –               | Dubbel     | ×                               | –                        | GDI                        | F4A42-1        | 4A/T    | –                             |
| Pajero/<br>Montero | V11V<br>V31V               | 4G64-6<br>(2,4)  | ×               | Enkel      | –                               | –                        | CARB                       | V5M21-6        | 5M/T    | ×                             |
|                    | V33V                       | 6G72-1<br>(3,0)  | –               | Dubbel     | ×                               | –                        | MPI                        | V5MT1-6        | 5M/T    | ×                             |
|                    |                            |                  | 6G72-8<br>(3,0) | –          | Dubbel                          | ×                        | –                          | MPI            | V4AW2-7 | 4A/T                          |
|                    |                            |                  |                 |            |                                 |                          |                            | V5MT1-6        | 5M/T    | ×                             |
|                    |                            |                  |                 |            |                                 |                          |                            | V4AW3-7        | 4A/T    | ×                             |
|                    | V14V<br>V34V               | 4D56-4<br>(2,5)  | ×               | Enkel      | –                               | –                        | Diesel<br>S-RGS            | V5M21-6        | 5M/T    | ×                             |
|                    | V36V                       | 4M40<br>(2,8)    | ×               | Enkel      | –                               | –                        | Diesel<br>S-RGS            | V5M21-6        | 5M/T    | ×                             |
|                    | V63W<br>V73W               | 6G72-8<br>(3,0)  | –               | Dubbel     | ×                               | –                        | MPI                        | V5MT1-8        | 5M/T    | ×                             |
|                    |                            |                  |                 |            |                                 |                          |                            | V5M31-6        | 5M/T    | ×                             |
|                    |                            |                  |                 |            |                                 |                          |                            | V4A51-7        | 4A/T    | ×                             |
| V65W<br>V75W       | 6G74-8<br>(3,5)            | –                | Dubbel          | ×          | –                               | MPI                      | V5M31-6                    | 5M/T           | ×       |                               |
|                    |                            |                  |                 |            |                                 |                          | V5A51-7                    | 5A/T           | ×       |                               |
|                    |                            | 6G74-B<br>(3,5)  | –               | Dubbel × 2 | ×                               | –                        | GDI                        | V5A51-7        | 5A/T    | ×                             |
| V66W<br>V76W       | 4M40<br>(2,8)              | ×                | Enkel           | –          | ×                               | Diesel<br>S-RGS          | V5M31-6                    | 5M/T           | ×       |                               |
|                    |                            |                  |                 |            |                                 |                          | V4A51-7                    | 4A/T           | ×       |                               |
| V78W               | 4M41<br>(3,2)              | ×                | Dubbel          | –          | ×                               | Diesel<br>S-RGS          | V5M31-6                    | 5M/T           | ×       |                               |
|                    |                            |                  |                 |            |                                 |                          | V5A51-7                    | 5A/T           | ×       |                               |
| L200               | K62T                       | 4G63-6<br>(2,0)  | ×               | Enkel      | ×                               | –                        | MPI                        | R5M21-5        | 5M/T    | –                             |
|                    |                            |                  | –               | Enkel      | ×                               | –                        | CARB                       | R5M21-5        | 5M/T    | –                             |
|                    | K64T                       | 4D56-4<br>(2,5)  | ×               | Enkel      | –                               | –                        | Diesel<br>S-RGS            | R5M21-5        | 5M/T    | –                             |



## 2002 modellen voor algemene export

| Voertuig-<br>model | Voertuig<br>model-<br>code | Motor            |          |          |                                 |                          | Brand-<br>stof-<br>systeem | Versnelingsbak     |              |                               |
|--------------------|----------------------------|------------------|----------|----------|---------------------------------|--------------------------|----------------------------|--------------------|--------------|-------------------------------|
|                    |                            | Model<br>(liter) | Balansas | Nokkenas | Hydrau-<br>lische<br>klepstoter | Turbo<br>compres-<br>sor |                            | Model              | Type         | Vierwiel-<br>aandrij-<br>ving |
| L200               | K65T                       | 4G64-2<br>(2,4)  | ×        | Enkel    | ×                               | –                        | MPI                        | R5M21-5            | 5M/T         | –                             |
|                    | K67T                       | 4M40<br>(2,8)    | ×        | Enkel    | –                               | –                        | Diesel<br>S-RGS            | R5M21-5            | 5M/T         | –                             |
|                    | K72T                       | 4G63-6<br>(2,0)  | –        | Enkel    | ×                               | –                        | CARB                       | V5M21-9            | 5M/T         | ×                             |
|                    | K74T                       | 4D56-4<br>(2,5)  | ×        | Enkel    | –                               | –                        | Diesel<br>S-RGS            | V5M21-9            | 5M/T         | ×                             |
|                    |                            |                  | ×        | Enkel    | –                               | ×                        | Diesel<br>S-RGS            | V5MT1-4            | 5M/T         | ×                             |
|                    | K75T                       | 4G64-2<br>(2,4)  | ×        | Enkel    | ×                               | –                        | MPI                        | V5M21-9            | 5M/T         | ×                             |
|                    | K77T                       | 4M40<br>(2,8)    | ×        | Enkel    | –                               | –                        | Diesel<br>S-RGS            | V5M21-9            | 5M/T         | ×                             |
| Pajero<br>iO       | H67W<br>H77W               | 4G94-D<br>(2,0)  | –        | Enkel    | –                               | –                        | MPI                        | V5M21-A<br>V4AW-D  | 5M/T<br>4A/T | ×                             |
|                    |                            |                  | –        | Dubbel   | ×                               | ×                        | GDI                        | V4AW5-D            | 4A/T         | ×                             |
| Challenger         | K86W                       | 6G72-8<br>(3,0)  | –        | Dubbel   | ×                               | –                        | MPI                        | R5M31-B<br>R4A51-5 | 5M/T<br>4A/T | –                             |
|                    | K96W                       | 6G72-8<br>(3,0)  | –        | Dubbel   | ×                               | –                        | MPI                        | V5MT1-D<br>V4A51-5 | 5M/T<br>4A/T | ×                             |
|                    | K97W                       | 4M40<br>(2,8)    | ×        | Enkel    | –                               | ×                        | Diesel<br>S-RGS            | V5M31-B<br>V4A51-5 | 5M/T<br>4A/T | ×                             |
| L300               | P03V<br>P13V               | 4G63-B<br>(2,0)  | –        | Enkel    | ×                               | –                        | CARB                       | R5M21-2            | 5M/T         | –                             |
|                    | P03W<br>P13W               | 4G63-B<br>(2,0)  | –        | Enkel    | ×                               | –                        | CARB                       | R5M21-2<br>R4AW2-8 | 5M/T<br>4A/T | –                             |
|                    | P06V<br>P16V               | 4G92-0<br>(1,6)  | –        | Enkel    | –                               | –                        | CARB                       | R5M21-2            | 5M/T         | –                             |

## 2002 modellen voor algemene export

| Voertuig-<br>model | Voertuig<br>model-<br>code | Motor            |          |          |                                 |                          | Brand-<br>stof-<br>systeem | Versnelingsbak     |              |                               |
|--------------------|----------------------------|------------------|----------|----------|---------------------------------|--------------------------|----------------------------|--------------------|--------------|-------------------------------|
|                    |                            | Model<br>(liter) | Balansas | Nokkenas | Hydrau-<br>lische<br>klepstoter | Turbo<br>compres-<br>sor |                            | Model              | Type         | Vierwiel-<br>aandrij-<br>ving |
| L300               | P13V<br>P13W               | 4G63-6<br>(2,0)  | ×        | Enkel    | ×                               | –                        | MPI                        | R5M21-2            | 5M/T         | –                             |
|                    | P15V<br>P15W               | 4D56-2<br>(2,5)  | ×        | Enkel    | –                               | –                        | Diesel<br>S-RGS            | R5M21-2            | 5M/T         | –                             |
|                    | P15V                       | 4D56-4<br>(2,5)  | ×        | Enkel    | –                               | –                        | Diesel<br>S-RGS            | R5M21-2            | 5M/T         | –                             |
|                    | P23W                       | 4G63-B<br>(2,0)  | –        | Enkel    | ×                               | –                        | CARB                       | V5M21-2            | 5M/T         | ×                             |
| L400               | PB3V                       | 4G63-B<br>(2,0)  | –        | Enkel    | ×                               | –                        | CARB                       | R5M21-7            | 5M/T         | –                             |
|                    | PB5V                       | 4D56-4<br>(2,5)  | ×        | Enkel    | –                               | ×                        | Diesel<br>S-RGS            | R5M21-7            | 5M/T         | –                             |
| Space<br>Gear      | PA3W                       | 4G63-B<br>(2,0)  | –        | Enkel    | ×                               | –                        | CARB                       | R4AW2-5            | 4A/T         | –                             |
|                    | PA4W                       | 4G64-2<br>(2,4)  | ×        | Enkel    | ×                               | –                        | MPI                        | R4AW2-5            | 4A/T         | –                             |
|                    | PA5W<br>PC5W               | 4D56-4<br>(2,5)  | ×        | Enkel    | –                               | ×                        | Diesel<br>S-RGS            | R5M21-7            | 5M/T         | –                             |
|                    | PC3W                       | 4G63-B<br>(2,0)  | –        | Enkel    | ×                               | –                        | CARB                       | R5M21-7            | 5M/T         | –                             |
|                    | PD3W                       | 4G63-B<br>(2,0)  | –        | Enkel    | ×                               | –                        | CARB                       | V5M21-7            | 5M/T         | ×                             |
|                    | PD4W                       | 4G64-2<br>(2,4)  | ×        | Enkel    | ×                               | –                        | MPI                        | V5M21-7            | 5M/T         | ×                             |
|                    | PD5W                       | 4D56-4<br>(2,5)  | ×        | Enkel    | –                               | ×                        | Diesel<br>S-RGS            | V5M21-7            | 5M/T         | ×                             |
| Sigma              | F38A                       | 6G74-5<br>(3,5)  | –        | Dubbel   | ×                               | –                        | MPI                        | F5M51-1<br>F4A51-2 | 5M/T<br>4A/T | –<br>–                        |

## 2002 modellen voor Australië

| Voertuig-<br>model         | Voertuig<br>model-<br>code | Motor            |          |          |                                 |                          | Brand-<br>stof-<br>systeem | Versnelingsbak     |              |                               |
|----------------------------|----------------------------|------------------|----------|----------|---------------------------------|--------------------------|----------------------------|--------------------|--------------|-------------------------------|
|                            |                            | Model<br>(liter) | Balansas | Nokkenas | Hydrau-<br>lische<br>klepstoter | Turbo<br>compres-<br>sor |                            | Model              | Type         | Vierwiel-<br>aandrij-<br>ving |
| Colt                       | CJ2A                       | 4G15-3<br>(1,5)  | –        | Enkel    | –                               | –                        | MPI                        | F5M41-1<br>F4A41-1 | 5M/T<br>4A/T | –<br>–                        |
|                            | CJ5A                       | 4G93-3<br>(1,8)  | –        | Enkel    | –                               | –                        | MPI                        | F5M42-1<br>F4A42-1 | 5M/T<br>4A/T | –<br>–                        |
| Lancer<br>Station<br>Wagon | CB5W                       | 4G93-0<br>(1,8)  | –        | Enkel    | –                               | –                        | MPI                        | F5M22-2<br>F4A22-2 | 5M/T<br>4A/T | –<br>–                        |
| Lancer                     | CK5A                       | 4G93-3<br>(1,8)  | –        | Enkel    | –                               | –                        | MPI                        | F5M42-1<br>F4A42-1 | 5M/T<br>4A/T | –<br>–                        |
|                            | CS6A                       | 4G94-3<br>(2,0)  | –        | Enkel    | –                               | –                        | MPI                        | F5M42-1<br>F4A42-1 | 5M/T<br>4A/T | –<br>–                        |
| Space<br>Wagon             | N84W                       | 4G64-2<br>(2,4)  | ×        | Enkel    | ×                               | –                        | MPI                        | F5M42-2<br>F4A42-2 | 5M/T<br>4A/T | –<br>–                        |
| Pajero/<br>Montero         | V75W                       | 6G74-8<br>(3,5)  | –        | Dubbel   | ×                               | –                        | MPI                        | V5M31-6<br>V5A51-7 | 5M/T<br>5A/T | ×                             |
|                            | V76W                       | 4M40<br>(2,8)    | ×        | Enkel    | –                               | ×                        | Diesel<br>S-RGS            | V5M31-6            | 5M/T         | ×                             |
|                            | V78W                       | 4M41<br>(3,2)    | ×        | Dubbel   | –                               | ×                        | Diesel<br>S-RGS            | V5M31-6<br>V5A51-7 | 5M/T<br>5A/T | ×                             |
| L200                       | K65T                       | 4G64-2<br>(2,4)  | ×        | Enkel    | ×                               | –                        | MPI                        | R5M21-5            | 5M/T         | –                             |
|                            | K66T                       | 6G72-8<br>(3,0)  | –        | Dubbel   | ×                               | –                        | MPI                        | R5M31-4<br>R4A51-4 | 5M/T<br>4A/T | –<br>–                        |
|                            | K76T                       | 6G72-8<br>(3,0)  | –        | Dubbel   | ×                               | –                        | MPI                        | V5MT1-C<br>V4A51-4 | 5M/T<br>4A/T | ×                             |
|                            | K77T                       | 4M40<br>(2,8)    | ×        | Enkel    | –                               | –                        | Diesel<br>S-RGS            | V5M21-9            | 5M/T         | ×                             |
| Challenger                 | K96W                       | 6G72-8<br>(3,0)  | –        | Dubbel   | ×                               | –                        | MPI                        | V5MT1-D<br>V4A51-5 | 5M/T<br>4A/T | ×                             |
| Pajero<br>iO               | H67W<br>H77W               | 4G94D<br>(2,0)   | –        | Enkel    | –                               | –                        | MPI                        | V5M21-A<br>V4AW4-D | 5M/T<br>4A/T | ×                             |

## 2002 modellen voor Australië

| Voertuig-<br>model | Voertuig<br>model-<br>code | Motor            |          |          |                                 |                          | Brand-<br>stof-<br>systeem | Versnelingsbak     |              |                               |
|--------------------|----------------------------|------------------|----------|----------|---------------------------------|--------------------------|----------------------------|--------------------|--------------|-------------------------------|
|                    |                            | Model<br>(liter) | Balansas | Nokkenas | Hydrau-<br>lische<br>klepstoter | Turbo<br>compres-<br>sor |                            | Model              | Type         | Vierwiel-<br>aandrij-<br>ving |
| L300               | P03V                       | 4G63-A<br>(2,0)  | ×        | Enkel    | ×                               | –                        | CARB                       | R5M21-2<br>R4AW2-8 | 5M/T<br>4A/T | –<br>–                        |
|                    | P03W                       | 4G63-6<br>(2,0)  | ×        | Enkel    | ×                               | –                        | MPI                        | R5M21-2<br>R4AW2-8 | 5M/T<br>4A/T | –<br>–                        |
|                    | P05V<br>P15V<br>P15W       | 4D56-4<br>(2,5)  | ×        | Enkel    | –                               | ×                        | Diesel<br>S-RGS            | R5M21-2            | 5M/T         | –                             |
|                    | P15V                       | 4D56-2<br>(2,5)  | ×        | Enkel    | –                               | –                        | Diesel<br>S-RGS            | R5M21-2            | 5M/T         | –                             |
|                    | P14V                       | 4G64-2<br>(2,4)  | ×        | Enkel    | ×                               | –                        | MPI                        | R5M21-2<br>R4AW2-8 | 5M/T<br>4A/T | –<br>–                        |
|                    | P04V<br>P14W               | 4G64-2<br>(2,4)  | ×        | Enkel    | ×                               | –                        | MPI                        | R5M21-2            | 5M/T         | –                             |
| L400               | PB4V                       | 4G64-2<br>(2,4)  | ×        | Enkel    | ×                               | –                        | MPI                        | R5M21-7<br>R4AW2-5 | 5M/T<br>4A/T | –<br>–                        |
| Space<br>Gear      | PA3W                       | 4G63-6<br>(2,0)  | ×        | Enkel    | ×                               | –                        | MPI                        | R5M21-7<br>R4AW2-5 | 5M/T<br>4A/T | –<br>–                        |
|                    | PA4W                       | 4G64-2<br>(2,4)  | ×        | Enkel    | ×                               | –                        | MPI                        | R4AW2-5            | 4A/T         | –                             |

## 2003 modellen voor Europa

| Voertuig-<br>model | Voertuig<br>model-<br>code | Motor            |          |          |                                 |                          | Brand-<br>stof-<br>systeem | Versnelingsbak     |              |                               |
|--------------------|----------------------------|------------------|----------|----------|---------------------------------|--------------------------|----------------------------|--------------------|--------------|-------------------------------|
|                    |                            | Model<br>(liter) | Balansas | Nokkenas | Hydrau-<br>lische<br>klepstoter | Turbo<br>compres-<br>sor |                            | Model              | Type         | Vierwiel-<br>aandrij-<br>ving |
| Colt               | CJ1A                       | 4G13-6<br>(1,3)  | –        | Enkel    | ×                               | –                        | MPI                        | F5M41-1            | 5M/T         | –                             |
|                    | CJ4A                       | 4G92-3<br>(1,6)  | –        | Enkel    | ×                               | –                        | MPI                        | F5M41-1<br>F4A41-1 | 5M/T<br>4A/T | –<br>–                        |
| Space<br>Star      | DG1A                       | 4G13-6<br>(1,3)  | –        | Enkel    | ×                               | –                        | MPI                        | JB3-241            | 5M/T         | –                             |
|                    | DG3A                       | 4G18-6<br>(1,6)  | –        | Enkel    | ×                               | –                        | MPI                        | JB3-244<br>F4A41-1 | 5M/T<br>4A/T | –<br>–                        |
|                    | DG4A                       | F9QT-0<br>(1,9)  | –        | Enkel    | –                               | –                        | Diesel<br>S-RGS            | F5MV1-L            | 5M/T         | –                             |
|                    |                            | F9QT-1<br>(1,9)  | –        | Enkel    | –                               | –                        | Diesel<br>S-RGS            | F5MV1-L            | 5M/T         | –                             |
|                    | DG5A                       | 4G93-3<br>(1,8)  | –        | Enkel    | ×                               | –                        | MPI                        | JB3-241<br>F4A42-1 | 5M/T<br>4A/T | –<br>–                        |
| Carisma            | DA1A                       | 4G92-2<br>(1,6)  | –        | Enkel    | ×                               | –                        | MPI                        | JB3-243<br>F4A41-1 | 5M/T<br>4A/T | –<br>–                        |
|                    | DA2A                       | 4G93-G<br>(1,8)  | –        | Dubbel   | ×                               | –                        | GDI                        | F5M42-1<br>F4A42-1 | 5M/T<br>4A/T | –<br>–                        |
|                    | DA5A                       | F9QT-0<br>(1,9)  | –        | Enkel    | –                               | ×                        | Diesel<br>S-RGS            | F5MV1-L            | 5M/T         | –                             |
|                    |                            | F9QT-1<br>(1,9)  | –        | Enkel    | –                               | ×                        | Diesel<br>S-RGS            | F5MV1-L            | 5M/T         | –                             |
|                    | DA6A                       | 4G13-6<br>(1,3)  | –        | Enkel    | ×                               | –                        | MPI                        | JB3-308            | 5M/T         | –                             |
| Space<br>Wagon     | N83W                       | 4G63-F<br>(2,0)  | ×        | Enkel    | ×                               | –                        | MPI                        | F5M42-2            | 5M/T         | –                             |
|                    | N84W                       | 4G64-4<br>(2,4)  | ×        | Dubbel   | ×                               | –                        | GDI                        | F5M42-2<br>F4A42-2 | 5M/T<br>4A/T | –<br>–                        |
|                    | N94W                       | 4G64-4<br>(2,4)  | ×        | Dubbel   | ×                               | –                        | GDI                        | W5M42-1            | 5M/T         | ×                             |

2003 modellen voor Europa

| Voertuig-<br>model | Voertuig<br>model-<br>code | Motor            |          |            |                                 |                          | Brand-<br>stof-<br>systeem | Versnelingsbak     |              |                               |   |
|--------------------|----------------------------|------------------|----------|------------|---------------------------------|--------------------------|----------------------------|--------------------|--------------|-------------------------------|---|
|                    |                            | Model<br>(liter) | Balansas | Nokkenas   | Hydrau-<br>lische<br>klepstoter | Turbo<br>compres-<br>sor |                            | Model              | Type         | Vierwiel-<br>aandrij-<br>ving |   |
| Pajero/<br>Montero | V64W<br>V74W               | 4D56-5<br>(2,5)  | ×        | Enkel      | –                               | ×                        | Diesel<br>S-RGS            | V5MT1-8<br>V5M31-6 | 5M/T<br>5M/T | ×                             | × |
|                    | V65W<br>V75W               | 6G74-B<br>(3,5)  | –        | Dubbel × 2 | ×                               | –                        | GDI                        | V5M31-6<br>V5A51-7 | 5M/T<br>5A/T | ×                             | × |
|                    | V68W<br>V78W               | 4M41<br>(3,2)    | ×        | Dubbel     | –                               | ×                        | Diesel<br>S-RGS            | V5M31-6<br>V5A51-7 | 5M/T<br>5A/T | ×                             | × |
| L200               | K64T                       | 4D56-4<br>(2,5)  | ×        | Enkel      | –                               | –                        | Diesel<br>S-RGS            | R5M21-5            | 5M/T         | –                             | – |
|                    |                            | 4D56-5<br>(2,5)  | ×        | Enkel      | –                               | ×                        | Diesel<br>S-RGS            | R5M21-5<br>R4AW2-6 | 5M/T<br>4A/T | –                             | – |
|                    | K74T                       | 4D56-4<br>(2,5)  | ×        | Enkel      | –                               | ×                        | Diesel<br>S-RGS            | V5MT1-4<br>V4AW2-6 | 5M/T<br>4A/T | ×                             | × |
|                    |                            | 4D56-5<br>(2,5)  | ×        | Enkel      | –                               | ×                        | Diesel<br>S-RGS            | V5MT1-4<br>V4AW2-6 | 5M/T<br>4A/T | ×                             | × |
|                    | K75T                       | 4G64-2<br>(2,4)  | ×        | Enkel      | ×                               | –                        | MPI                        | V5M21-9            | 5M/T         | ×                             | × |
| Pajero<br>Sport    | K94W                       | 4D56-4<br>(2,5)  | ×        | Enkel      | –                               | ×                        | Diesel<br>S-RGS            | V5MT1-B            | 5M/T         | ×                             | × |
|                    |                            | 4D56-5<br>(2,5)  | ×        | Enkel      | –                               | ×                        | Diesel<br>S-RGS            | V5MT1-D            | 5M/T         | ×                             | × |
|                    | K96W                       | 6G72-8<br>(3,0)  | –        | Dubbel     | ×                               | –                        | MPI                        | V5MT1-D<br>V4A51-5 | 5M/T<br>4A/T | ×                             | × |
| Pajero<br>Pinin    | H66W<br>H76W               | 4G93-D<br>(1,8)  | –        | Enkel      | ×                               | –                        | MPI                        | V5M21-A<br>V4AW4-D | 5M/T<br>4A/T | ×                             | × |
|                    | H67W<br>H77W               | 4G94-H<br>(2,0)  | –        | Dubbel     | ×                               | –                        | GDI                        | V5M21-A<br>V4AW4-D | 5M/T<br>4A/T | ×                             | × |

## 2003 modellen voor algemene export

| Voertuig-<br>model         | Voertuig<br>model-<br>code | Motor            |          |          |                                 |                          | Brand-<br>stof-<br>systeem | Versnelingsbak     |              |                               |
|----------------------------|----------------------------|------------------|----------|----------|---------------------------------|--------------------------|----------------------------|--------------------|--------------|-------------------------------|
|                            |                            | Model<br>(liter) | Balansas | Nokkenas | Hydrau-<br>lische<br>klepstoter | Turbo<br>compres-<br>sor |                            | Model              | Type         | Vierwiel-<br>aandrij-<br>ving |
| Colt                       | CJ1A                       | 4G13-5<br>(1,3)  | –        | Enkel    | –                               | –                        | CARB                       | F5M41-1            | 5M/T         | –                             |
|                            | CJ2A                       | 4G15-5<br>(1,5)  | –        | Enkel    | –                               | –                        | CARB                       | F5M41-1<br>F4A41-1 | 5M/T<br>4A/T | –<br>–                        |
|                            | CJ4A                       | 4G92-3<br>(1,6)  | –        | Enkel    | –                               | –                        | MPI                        | F5M41-1<br>F4A41-1 | 5M/T<br>4A/T | –<br>–                        |
| Lancer                     | CS1A                       | 4G13-6<br>(1,3)  | –        | Enkel    | –                               | –                        | MPI                        | F5M41-1<br>F4A41-1 | 5M/T<br>4A/T | –<br>–                        |
|                            | CS3A                       | 4G18-6<br>(1,6)  | –        | Enkel    | –                               | –                        | MPI                        | F5M41-1<br>F1C1A-1 | 5M/T<br>CVT  | –<br>–                        |
| Lancer<br>Station<br>Wagon | CB1W                       | 4G13-2<br>(1,3)  | –        | Enkel    | –                               | –                        | CARB                       | F5M21-1<br>F3A21-2 | 5M/T<br>3A/T | –<br>–                        |
|                            | CB2W                       | 4G15-2<br>(1,5)  | –        | Enkel    | –                               | –                        | CARB                       | F5M21-1<br>F3A21-2 | 5M/T<br>3A/T | –<br>–                        |
|                            | CB4W                       | 4G92-0<br>(1,6)  | –        | Enkel    | –                               | –                        | MPI                        | F5M22-2<br>F4A22-2 | 5M/T<br>4A/T | –<br>–                        |
| Space<br>Wagon             | N84W                       | 4G64-2<br>(2,4)  | ×        | Enkel    | ×                               | –                        | MPI                        | F5M42-2<br>F4A42-2 | 5M/T<br>4A/T | –<br>–                        |
|                            |                            | 4G64-4<br>(2,4)  | ×        | Dubbel   | ×                               | –                        | GDI                        | F4A42-2            | 4A/T         | –                             |

2003 modellen voor algemene export

| Voertuig-<br>model | Voertuig<br>model-<br>code | Motor            |          |            |                                 |                          | Brand-<br>stof-<br>systeem | Versnelingsbak                |                      |                               |
|--------------------|----------------------------|------------------|----------|------------|---------------------------------|--------------------------|----------------------------|-------------------------------|----------------------|-------------------------------|
|                    |                            | Model<br>(liter) | Balansas | Nokkenas   | Hydrau-<br>lische<br>klepstoter | Turbo<br>compres-<br>sor |                            | Model                         | Type                 | Vierwiel-<br>aandrij-<br>ving |
| Pajero/<br>Montero | V11V<br>V31V               | 4G64-6<br>(2,4)  | ×        | Enkel      | –                               | –                        | CARB                       | V5M21-6                       | 5M/T                 | ×                             |
|                    | V14V<br>V34V               | 4D56-4<br>(2,5)  | ×        | Enkel      | –                               | –                        | Diesel<br>S-RGS            | V5M21-6                       | 5M/T                 | ×                             |
|                    | V36V                       | 4M40<br>(2,8)    | ×        | Enkel      | –                               | –                        | Diesel<br>S-RGS            | V5M21-6                       | 5M/T                 | ×                             |
|                    | V63W<br>V73W               | 6G72-8<br>(3,0)  | –        | Dubbel     | ×                               | –                        | MPI                        | V5MT1-9<br>V5M31-6<br>V4A51-7 | 5M/T<br>5M/T<br>4A/T | ×                             |
|                    | V65W<br>V75W               | 6G74-8<br>(3,5)  | –        | Dubbel     | ×                               | –                        | MPI                        | V5M31-6<br>V5A51-7            | 5M/T<br>5A/T         | ×                             |
|                    | V66W<br>V76W               | 4M40<br>(2,8)    | ×        | Enkel      | –                               | ×                        | Diesel<br>S-RGS            | V5M31-6<br>V4A51-7            | 5M/T<br>4A/T         | ×                             |
|                    | V75W                       | 6G74-B<br>(3,5)  | –        | Dubbel × 2 | ×                               | –                        | GDI                        | V5A51-7                       | 5A/T                 | ×                             |
|                    | V78W                       | 4M41<br>(3,2)    | ×        | Dubbel     | –                               | ×                        | Diesel<br>S-RGS            | V5M31-6<br>V5A51-7            | 5M/T<br>5A/T         | ×                             |
| L200               | K62T                       | 4G63-6<br>(2,0)  | ×        | Single     | ×                               | –                        | MPI                        | R5M21-5                       | 5M/T                 | –                             |
|                    |                            | 4G63-B<br>(2,0)  | –        | Enkel      | ×                               | –                        | CARB                       | R5M21-5                       | 5M/T                 | –                             |
|                    | K64T                       | 4D56-4<br>(2,5)  | ×        | Enkel      | –                               | –                        | Diesel<br>S-RGS            | R5M21-5                       | 5M/T                 | –                             |
|                    | K65T                       | 4G64-2<br>(2,4)  | ×        | Enkel      | ×                               | –                        | MPI                        | R5M21-5                       | 5M/T                 | –                             |



## 2003 modellen voor algemene export

| Voertuig-<br>model | Voertuig<br>model-<br>code | Motor            |          |          |                                 |                          | Brand-<br>stof-<br>systeem | Versnelingsbak     |              |                               |
|--------------------|----------------------------|------------------|----------|----------|---------------------------------|--------------------------|----------------------------|--------------------|--------------|-------------------------------|
|                    |                            | Model<br>(liter) | Balansas | Nokkenas | Hydrau-<br>lische<br>klepstoter | Turbo<br>compres-<br>sor |                            | Model              | Type         | Vierwiel-<br>aandrij-<br>ving |
| L200               | K67T                       | 4M40<br>(2,8)    | ×        | Enkel    | –                               | –                        | Diesel<br>S-RGS            | R5M21-5<br>R4AW2-6 | 5M/T<br>4A/T | –<br>–                        |
|                    | K72T                       | 4G63-G<br>(2,0)  | –        | Enkel    | ×                               | –                        | CARB                       | V5M21-9            | 5M/T         | ×                             |
|                    | K74T                       | 4D56-4<br>(2,5)  | ×        | Enkel    | –                               | –                        | Diesel<br>S-RGS            | V5M21-9            | 5M/T         | ×                             |
|                    |                            |                  | ×        | Enkel    | –                               | ×                        | Diesel<br>S-RGS            | V5MT1-4            | 5M/T         | ×                             |
|                    | K75T                       | 4G64-2<br>(2,4)  | ×        | Enkel    | ×                               | –                        | MPI                        | V5M21-9            | 5M/T         | ×                             |
|                    | K77T                       | 4M40<br>(2,8)    | ×        | Enkel    | –                               | –                        | Diesel<br>S-RGS            | V5M21-9            | 5M/T         | ×                             |
| Challenger         | K86W                       | 6G72-8<br>(3,0)  | –        | Dubbel   | ×                               | –                        | MPI                        | R5M31-B<br>R4A51-5 | 5M/T<br>4A/T | –<br>–                        |
|                    | K96W                       | 6G72-8<br>(3,0)  | –        | Dubbel   | ×                               | –                        | MPI                        | V5MT1-D<br>V4A51-5 | 5M/T<br>4A/T | ×                             |
|                    | K97W                       | 4M40<br>(2,8)    | ×        | Enkel    | –                               | ×                        | Diesel<br>S-RGS            | V5M31-B<br>V4A51-5 | 5M/T<br>4A/T | ×                             |
| Sigma              | F38A                       | 6G74-5<br>(3,5)  | –        | Dubbel   | ×                               | –                        | MPI                        | F5M51-1<br>F4A51-2 | 5M/T<br>4A/T | –<br>–                        |

2003 modellen voor Australië

| Voertuig-<br>model         | Voertuig<br>model-<br>code | Motor            |          |          |                                 |                          | Brand-<br>stof-<br>systeem | Versnelingsbak     |              |                               |
|----------------------------|----------------------------|------------------|----------|----------|---------------------------------|--------------------------|----------------------------|--------------------|--------------|-------------------------------|
|                            |                            | Model<br>(liter) | Balansas | Nokkenas | Hydrau-<br>lische<br>klepstoter | Turbo<br>compres-<br>sor |                            | Model              | Type         | Vierwiel-<br>aandrij-<br>ving |
| Colt                       | CJ2A                       | 4G15-3<br>(1,5)  | -        | Enkel    | -                               | -                        | MPI                        | F5M41-1<br>F4A41-1 | 5M/T<br>4A/T | -<br>-                        |
|                            | CJ5A                       | 4G93-3<br>(1,8)  | -        | Enkel    | -                               | -                        | MPI                        | F5M42-1<br>F4A42-1 | 5M/T<br>4A/T | -<br>-                        |
| Lancer<br>Station<br>Wagon | CB5W                       | 4G93-0<br>(1,8)  | -        | Enkel    | -                               | -                        | MPI                        | F5M22-2<br>F4A22-2 | 5M/T<br>4A/T | -<br>-                        |
| Lancer                     | CK5A                       | 4G93-3<br>(1,8)  | -        | Enkel    | -                               | -                        | MPI                        | F5M42-1<br>F4A42-1 | 5M/T<br>4A/T | -<br>-                        |
|                            | CS6A                       | 4G94-3<br>(2,0)  | -        | Enkel    | -                               | -                        | MPI                        | F5M42-1<br>F4A42-1 | 5M/T<br>4A/T | -<br>-                        |
| Space<br>Wagon             | N84W                       | 4G64-2<br>(2,4)  | x        | Enkel    | x                               | -                        | MPI                        | F5M42-2<br>F4A42-2 | 5M/T<br>4A/T | -<br>-                        |
| Pajero/<br>Montero         | V75W                       | 6G74-8<br>(3,5)  | -        | Dubbel   | x                               | -                        | MPI                        | V5M31-6<br>V5A51-7 | 5M/T<br>5A/T | x<br>x                        |
|                            | V76W                       | 4M40<br>(2,8)    | x        | Enkel    | -                               | x                        | Diesel<br>S-RGS            | V5M31-6<br>V5A51-7 | 5M/T<br>5A/T | x<br>x                        |
| L200                       | K65T                       | 4G64-2<br>(2,4)  | x        | Enkel    | x                               | -                        | MPI                        | R5M21-5            | 5M/T         | -                             |
|                            | K66T                       | 6G72-8<br>(3,0)  | -        | Dubbel   | x                               | -                        | MPI                        | R5M31-4<br>R4A51-4 | 5M/T<br>4A/T | -<br>-                        |
|                            | K76T                       | 6G72-8<br>(3,0)  | -        | Dubbel   | x                               | -                        | MPI                        | V5MT1-C<br>V4A51-4 | 5M/T<br>4A/T | x<br>x                        |
|                            | K77T                       | 4M40<br>(2,8)    | x        | Enkel    | -                               | -                        | Diesel<br>S-RGS            | V5M21-9            | 5M/T         | x                             |
|                            |                            |                  | x        | Enkel    | -                               | x                        | Diesel<br>S-RGS            | V5M31-C            | 5M/T         | x                             |
| Challenger K96W            |                            | 6G72-8<br>(3,0)  | -        | Dubbel   | x                               | -                        | MPI                        | V5MT1-D<br>V4A51-5 | 5M/T<br>4A/T | x<br>x                        |

## 2. MOTORMODEL- EN SERIENUMMER

### PLAATS VAN MOTORMODEL- EN SERIENUMMER

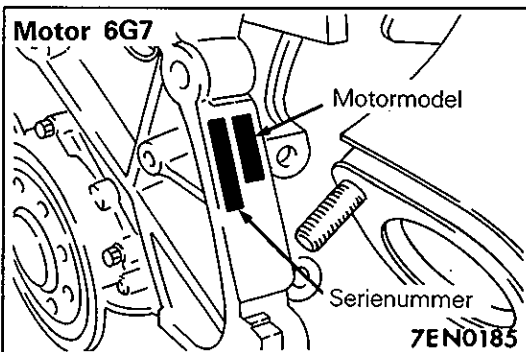
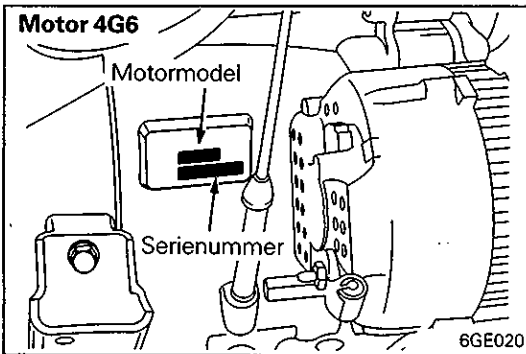
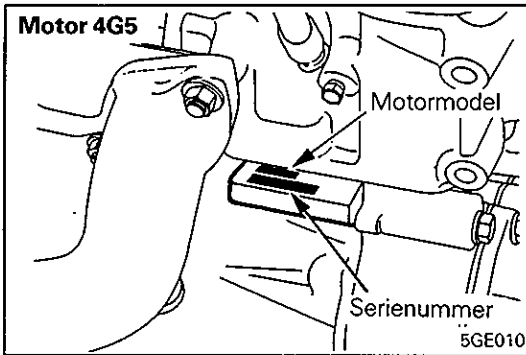
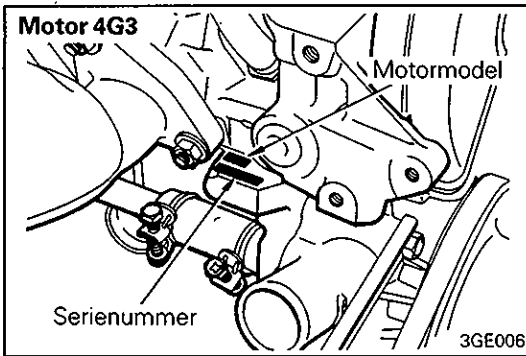
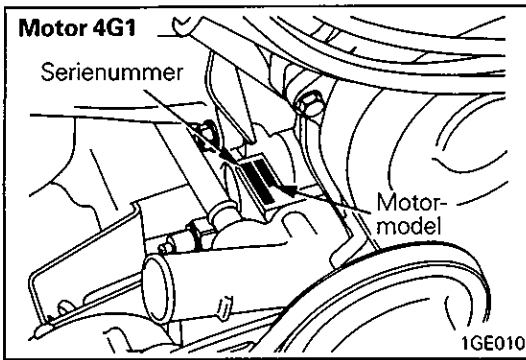
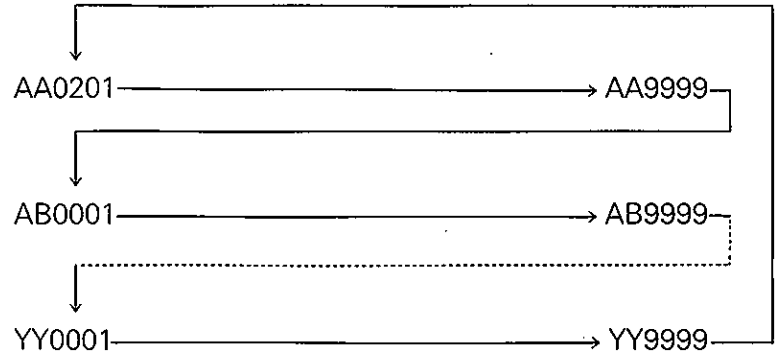

- (1) Het ingeslagen motormodel- en serienummer bevinden zich op de in de afbeelding aangegeven plaatsen.
- (2) Alle motorserienummers zijn uit 6 cijfers samengesteld:

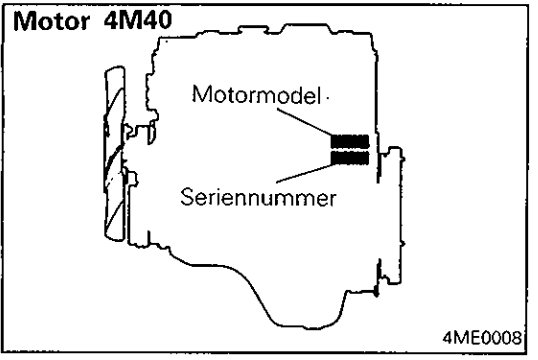
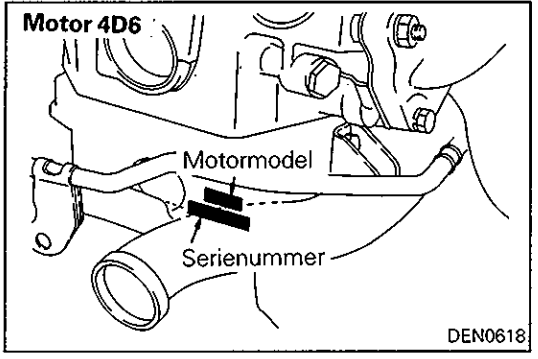
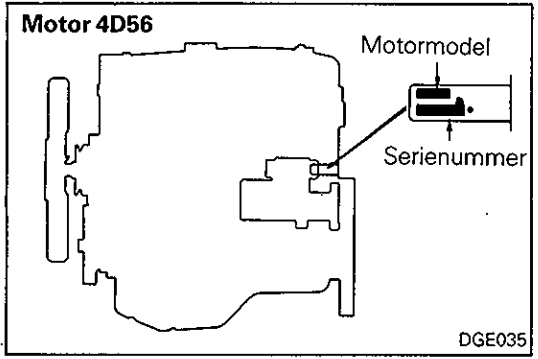
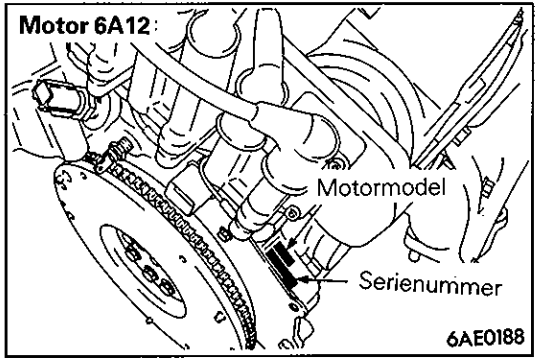
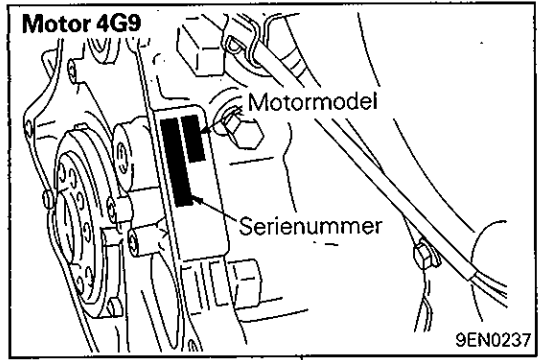

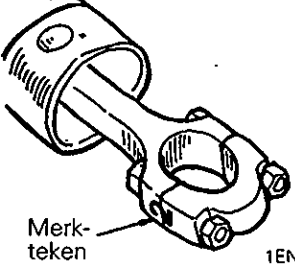
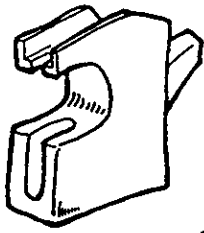
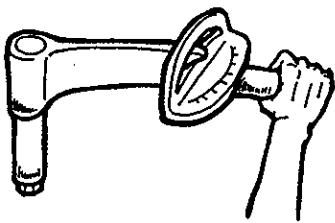

### 3. VOORZORGSMATREGELEN TIJDENS ONDERHOUD

Let tijdens demontage en montage van de motor en versnellingsbak op het volgende:

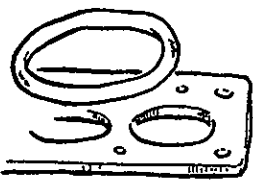
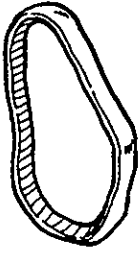
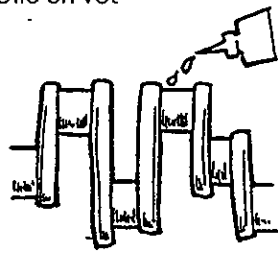
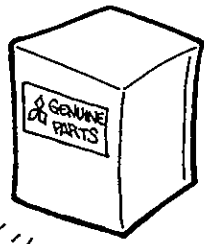
|   |   |   |   |
|---|---|---|---|
| <p>Uitbouwen en demonteren</p>  <p>Merktteken</p> <p>1EN0018</p> | <p>Om foutief inbouwen en monteren van onderdelen te voorkomen, moeten merktokens aangebracht worden op plaatsen waar de werking niet nadelig beïnvloed wordt.</p>                                      | <p>Speciaal gereedschap</p>  <p>1EN0019</p>   | <p>Het speciaal gereedschap moet altijd gebruikt worden als dit in de tekst vermeld wordt. Gebruik van ander gereedschap zal resulteren in beschadiging of een slechte werking van het betreffende onderdeel.</p> |
| <p>Aantrekkoppels</p>  <p>1EN0020</p>                            | <p>Zet de onderdelen met het voorgeschreven aantrekkoppel vast.</p>   | <p>Afdichtmiddel</p>  <p>1EN0021</p>          | <p>Gebruik altijd het aanbevolen merk afdichtmiddel. Gebruik van andere afdichtmiddelen kan vloeistof- of olielekage tot gevolg hebben.</p>   |
| <p>Vervangingsonderdelen</p>  <p>1EN0022</p>                    | <p>Eenmaal verwijderd moeten bij montage oliekeerringen, O-ringen en pakkingen door nieuwe onderdelen vervangen worden. De kleppendevelopping kan, indien niet beschadigd, opnieuw gebruikt worden.</p> | <p>Rubber onderdelen</p>  <p>1EN0023</p>     | <p>Zorg ervoor dat de distributieriem en V-riem niet door olie of brandstof vervuild worden. Derhalve mogen poelies en tandwielen niet met een oplosmiddel schoongemaakt worden.</p>                              |
| <p>Olie en vet</p>  <p>1EN0024</p>                             | <p>Smeer voor montage aanbevolen olie op draaiende en glijdende onderdelen.</p>   | <p>Originele onderdelen</p>  <p>1EN0025</p> | <p>Maak bij vervanging uitsluitend gebruik van originele Mitsubishi onderdelen. Raadpleeg de onderdelencatalogus voor de keuze van het juiste onderdeel.</p>  |

---

## NOTITIES

## 4. AANTREKKOPPELS

De algemene aantrekkoppels zijn in de volgende tabel gegeven.

Bijzondere aantrekkoppels van bepaalde onderdelen worden vermeld aan het begin van ieder hoofdstuk.

### AANTREKKOPPELS VAN STANDAARDONDERDELEN

#### AANTREKKOPPELS VAN BOUTEN OF MOEREN MET VERENDE ONDERLEGRINGEN

| Classificatie<br>Aantrekkoppels         | Kopmerkteken 4 |     | Kopmerkteken 7 |     | Kopmerkteken 10 |      |
|---|----------------|-----|----------------|-----|-----------------|------|
|   | Nm             | mkg | Nm             | mkg | Nm              | mkg  |
| Maat-schroef-draad mm<br>(dia. x spoed) |                |     |                |     |                 |      |
| 5 x 0,8                                 | –              | –   | 5,0            | 0,5 | –               | –    |
| 6 x 1,0                                 | –              | –   | 9,0            | 0,9 | 13              | 1,3  |
| 8 x 1,25                                | 11             | 1,1 | 18             | 1,8 | 30              | 3,0  |
| 10 x 1,25                               | 20             | 2,0 | 34             | 3,4 | 60              | 6,0  |
| 12 x 1,25                               | 36             | 3,6 | 62             | 6,2 | 108             | 10,8 |
| 14 x 1,5                                | 55             | 5,5 | 92             | 9,2 | 175             | 17,5 |

#### AANTREKKOPPELS VAN FLENSBOUTEN OF FLENSMOEREN

| Classificatie<br>Aantrekkoppels            | Kopmerkteken 4 |     | Kopmerkteken 7 |     |
|--|----------------|-----|----------------|-----|
|  | Nm             | mkg | Nm             | mkg |
| Maat v. schroef-draad mm<br>(dia. x spoed) |                |     |                |     |
| 5 x 0,8                                    | –              | –   | 6,0            | 0,6 |
| 6 x 1,0                                    | –              | –   | 11             | 1,1 |
| 8 x 1,25                                   | 14             | 1,4 | 24             | 2,4 |
| 10 x 1,25                                  | 30             | 3,0 | 50             | 5,0 |
| 12 x 1,25                                  | 55             | 5,5 | 90             | 9,0 |
| 14 x 1,5                                   | –              | –   | –              | –   |

#### AANTREKKOPPELS VAN ZELFTAPPENDE SCHROEVEN

| Classificatie<br>Aantrekkoppels | Aluminiumlegering |             | Gietijzer of staal |             |
|---------------------------------|-------------------|-------------|--------------------|-------------|
|                                 | Nm                | mkg         | Nm                 | mkg         |
| Maat schroefdraad               |                   |             |                    |             |
| 1/16                            | 5,0 – 8,0         | 0,5 – 0,8   | 8,0 – 12           | 0,8 – 1,2   |
| 1/8                             | 8,0 – 12          | 0,8 – 1,2   | 15 – 22            | 1,5 – 2,2   |
| 1/4                             | 20 – 30           | 2,0 – 3,0   | 35 – 45            | 3,5 – 4,5   |
| 3/8                             | 40 – 55           | 4,0 – 5,5   | 55 – 75            | 5,5 – 7,5   |
| 1/2                             | 70 – 100          | 7,0 – 10,0  | 120 – 160          | 12,0 – 16,0 |
| 3/4                             | 140 – 190         | 14,0 – 19,0 | 230 – 280          | 23,0 – 28,0 |

---

## NOTITIES