

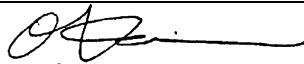

# SERVICE BULLETIN

PUBLICATION GROUP, AFTER SALES SERVICE DEP.  
MITSUBISHI MOTOR SALES EUROPE BV

<b>SERVICE BULLETIN</b>		No.: ESB-98E23-501	
		Date: 1999-06-15	<Model> <M/Y>
<b>Subject:</b>	ADDITION / CORRECTION OF HYDRAULIC PRESSURE TEST OF AUTOMATIC TRANSMISSION	(EUR) CARISMA (DX)	96-10
<b>Group:</b>	AUTOMATIC TRANSMISSION		
<b>INFORMATION</b>	 O. Kai - E.V.P. & G.M. After Sales Service Dept.		

### 1. Description:

This service bulletin informs you concerning addition and correction of the hydraulic pressure test of the automatic transmission.

### 2. Applicable Manuals:

Manual	Pub. No.	Language	Page(s)
'96 CARISMA Workshop Manual chassis	PWDE9502	(English)	23-56, 23-57
	PWDS9503	(Spanish)	
	PWDF9504	(French)	
	PWDG9505	(German)	
	PWDD9506	(Dutch)	
	PWDW9507	(Swedish)	
	PWDI96E1	(Italian)	

### 3. Details:

### TORQUE CONVERTER STALL TEST JUDGEMENT RESULTS

- a. Stall speed is too high in both D and R ranges
  - Low line pressure
  - Low & reverse brake slippage
- b. Stall speed is too high in D range only
  - Underdrive clutch slippage
- c. Stall speed is too high in R range only
  - Reverse clutch slippage
- d. Stall speed too low in both D and R ranges
  - Malfunction of torque converter
  - Insufficient engine output.

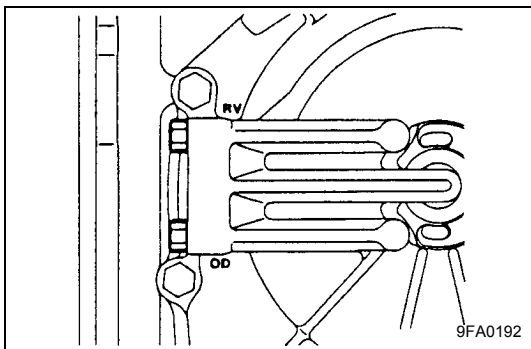
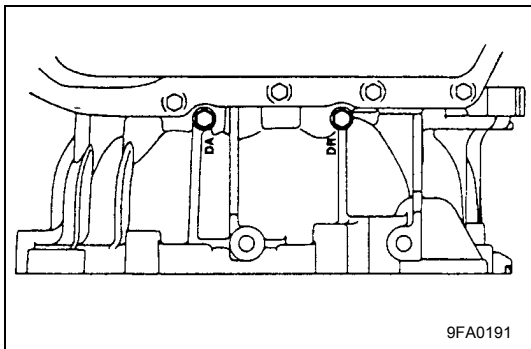
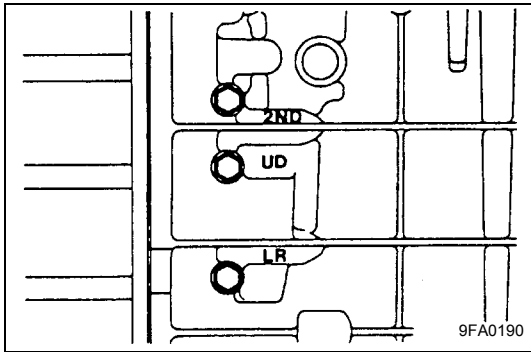

### HYDRAULIC PRESSURE TEST

23100550032

- (1) Warm up the engine until the automatic transmission fluid temperature is 80 – 100°C.
- (2) Jack up the vehicle so that the wheels are free to turn.
- (3) Connect the special tools (2,942-kPa oil pressure gauge [MD998330] and joints [MD998332, MD998900]) to each pressure discharge port.
- (4) Measure the hydraulic pressure at each port under the conditions given in the standard hydraulic pressure table, and check that the measured values are within the standard value ranges.
- (5) If a value is outside the standard range, correct the problem while referring to the hydraulic pressure test diagnosis table.

#### <Added>

##### NOTE

- 2ND : Second brake pressure port
- UD : Under drive clutch pressure port
- LR : Low & reverse brake pressure port
- DR : Torque converter pressure port
- DA : Damper clutch apply pressure port
- RV : Reverse clutch pressure port
- OD : Overdrive clutch pressure port

**STANDARD HYDRAULIC PRESSURE TEST**

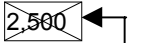
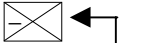
Measurement condition			Standard hydraulic pressure kPa					
Selector lever position	Shift position	Engine speed (rpm)	Under drive clutch pressure [UD] <Added>	Reverse clutch pressure [RV] <Added>	Overdrive clutch pressure [OD] <Added>	Low and reverse brake pressure [LR] <Added>	Second brake pressure [2ND] <Added>	Torque converter pressure [DR] <Added>
P	-	2,500	-	-	-	310-390	-	250-390
R	Reverse <Incorrect>	2,500 <Incorrect>	-	1,270-1,770	-	1,270-1,770	-	500-700
N			-	-	-	310-390	-	250-390
D	1st gear	2,500	1,010-1,050	-	-	1,010-1,050	-	500-700
2	2nd gear	2,500	1,010-1,050	-	-	-	1,010-1,050	500-700
3	3rd gear	2,500	590-690	-	590-690	-	-	450-650
D	4th gear	2,500	-	-	590-690	-	590-690	450-650

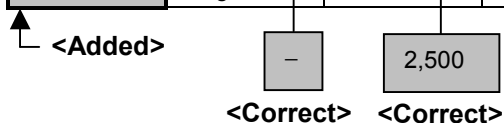

**HYDRAULIC PRESSURE TEST DIAGNOSIS TABLE**

Trouble symptom	Probable cause
All hydraulic pressures are high.	Incorrect transmission control cable adjustment
	Malfunction of the regulator valve
All hydraulic pressures are low.	Incorrect transmission control cable adjustment
	Malfunction of the oil pump
	Clogged internal oil filter
	Clogged external oil filter
	Clogged oil cooler
	Malfunction of the regulator valve
	Malfunction of the relief valve
Incorrect valve body installation	