

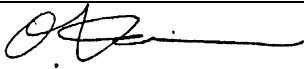

# SERVICE BULLETIN

PUBLICATION GROUP, AFTER SALES SERVICE DEP.  
MITSUBISHI MOTOR SALES EUROPE BV

<b>SERVICE BULLETIN</b>		No.: ESB-97E51-501	
		Date: 1998-03-15	<Model> <M/Y>
<b>Subject:</b>	CENTER CONSOLE PANEL AND CUP HOLDER REMOVAL	(EC,EXP) CARISMA	96-10
<b>Group:</b>	INTERIOR		
<b>CORRECTION</b>	 O. Kai - E.V.P. & G.M. After Sales Service Dept.		

### 1. Description:

This Service Bulletin informs you of addition of a removal procedure for the center console panel and cup holder assembly

### 2. Applicable Manuals:

Manual	Pub. No.	Language	Page(s)
'96 CARISMA Workshop Manual chassis	PWDE9502	(English)	52A-7
	PWDS9503	(Spanish)	
	PWDF9504	(French)	
	PWDG9505	(German)	
	PWDD9506	(Dutch)	
	PWDW9507	(Swedish)	
	PWDI96E1	(Italian)	

### 3. Details:

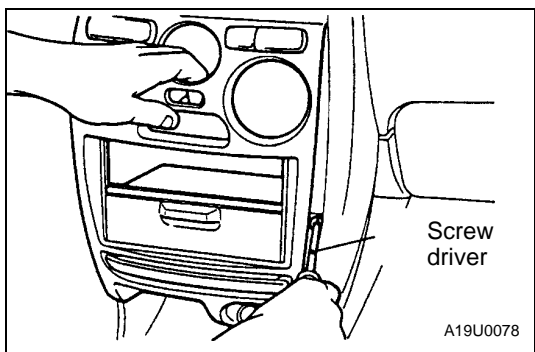

**REMOVAL SERVICE POINTS**

**◀ A ▶ CENTER CONSOLE PANEL AND CUP HOLDER ASSEMBLY REMOVAL**

- ▶ 1. After removing the center console mounting screws, pull the center console panel towards you to remove it together with the cup holder, inner
- ▶ 2. Insert a screwdriver into the space as shown in the illustration to remove the center console panel and cup holder assembly

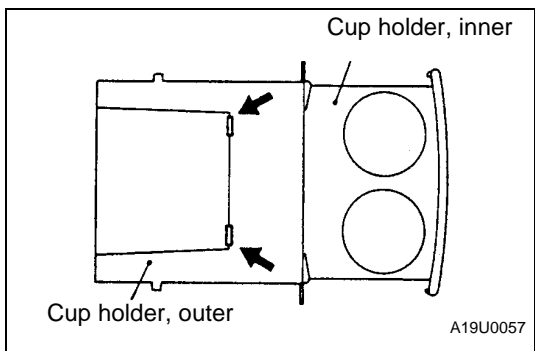

**◀ B ▶ CUP HOLDER, INNER REMOVAL**

Push the cup holder, outer in the places shown in the illustration to remove the cup holder, inner.

- 3
- 2 <Changed>

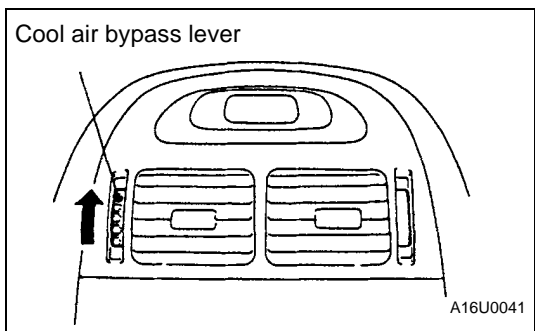

**INSTALLATION SERVICE POINT**

**▶ A ◀ CENTER AIR OUTLET ASSEMBLY INSTALLATION**

1. Turn the cool air bypass lever of the center air outlet assembly fully upward.
2. Turn the cool air bypass damper at the heater unit side fully downward, and install the cool air bypass lever cable.

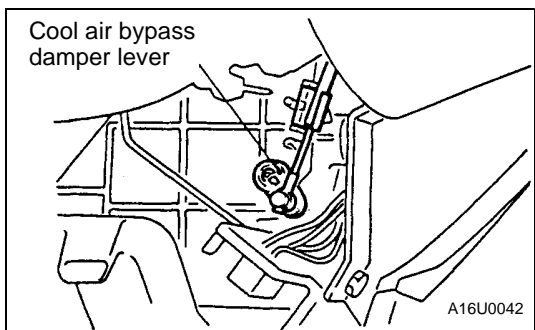

<Added>

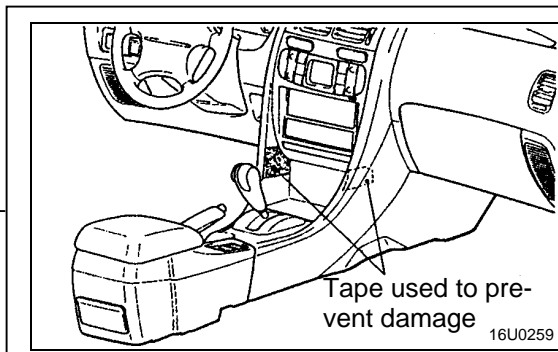

1. Affix a tape to the front floor console assembly to prevent it from being damaged.