

STEERING

CONTENTS

3720900057

GENERAL INFORMATION	2	Drive Belt Tension Check	7
SERVICE SPECIFICATIONS	3	Fluid Level Check	7
LUBRICANTS	3	Fluid Replacement	8
SPECIAL TOOLS	3	Bleeding	8
ON-VEHICLE SERVICE	5	Oil Pump Pressure Test	10
Steering Wheel Free Play Check	5	Power Steering Oil Pressure Switch Check	11
Steering Angle Check	5	STEERING WHEEL AND SHAFT*	12
Tie Rod End Ball Joint Starting Torque Check	6	POWER STEERING GEAR BOX*	15
Stationary Steering Effort Check	6	POWER STEERING OIL PUMP	19
Checking Steering Wheel Return to Centre	7	POWER STEERING HOSES	20

WARNINGS REGARDING SERVICING OF SUPPLEMENTAL RESTRAINT SYSTEM (SRS) EQUIPPED VEHICLES

WARNING!

- (1) Improper service or maintenance of any component of the SRS, or any SRS-related component, can lead to personal injury or death to service personnel (from inadvertent firing of the air bag) or to the driver and passenger (from rendering the SRS inoperative).
- (2) Service or maintenance of any SRS component or SRS-related component must be performed only at an authorized MITSUBISHI dealer.
- (3) MITSUBISHI dealer personnel must thoroughly review this manual, and especially its GROUP 52B – Supplemental Restraint System (SRS) before beginning any service or maintenance of any component of the SRS or any SRS-related component.

NOTE

The SRS includes the following components: SRS-ECU, SRS warning lamp, air bag module, clock spring and interconnecting wiring. Other SRS-related components (that may have to be removed/installed in connection with SRS service or maintenance) are indicated in the table of contents by an asterisk (*).

GENERAL INFORMATION

37200010059

The steering wheel is a 3-spoke type for standard models and a 4-spoke type for vehicles with SRS. The steering column is equipped with both shock absorbing and a tilt steering mechanism. The power steering is an integral rack and pinion

type that combines the steering gear and linkage into one light-weight and compact assembly. The steering system uses a vane oil pump with a fluid flow control system, so that steering effort varies with engine speed.

Items		Specifications
Steering gear and linkage	Type	Integral type
	Gear type	Rack and pinion
Oil pump	Type	Vane type
	Displacement ml/rev.	7.1
	Relief set pressure MPa	9.8

CONSTRUCTION DIAGRAM

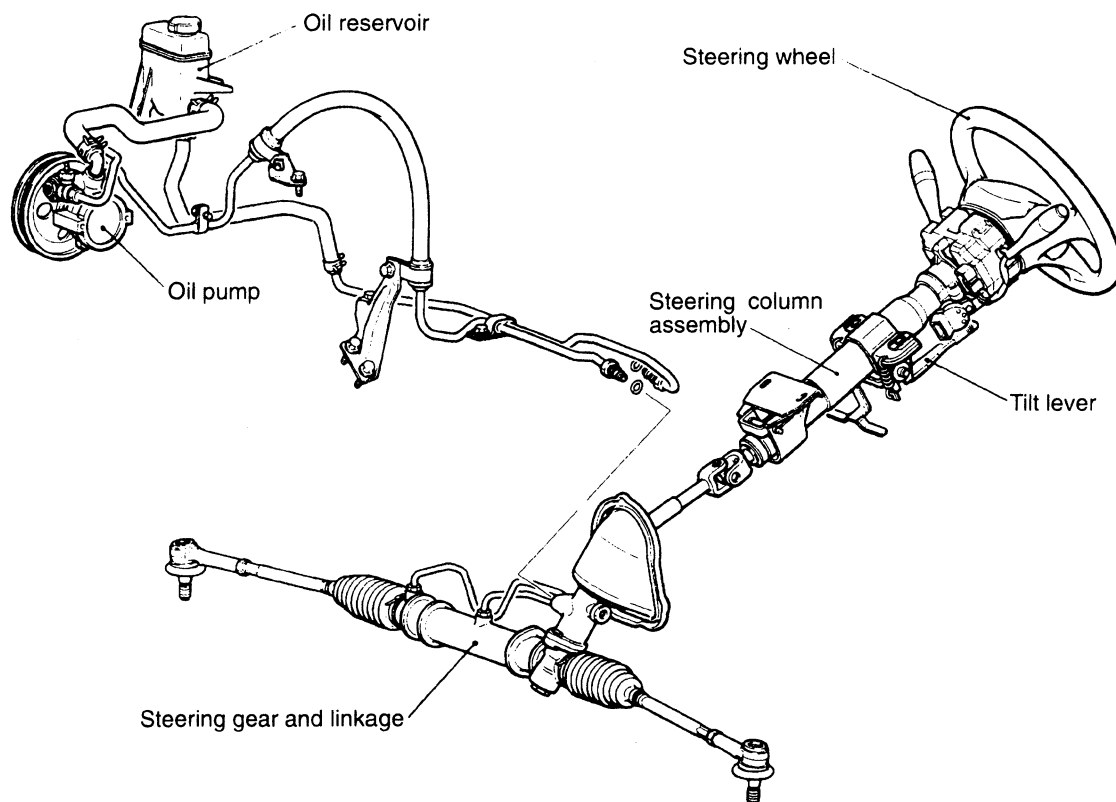

A13U0004

SERVICE SPECIFICATIONS

37200030055

Items		Standard value	Limit
Steering wheel free play mm	with engine stopped	10 or less	–
	when hydraulic operation	–	30
Steering angle	Inner wheel	39°00'±1°30'	–
	Outer wheel	32°00'	–
Tie rod end ball joint starting torque Nm		1.0–3.0	–
Stationary steering effort N (Fluctuation allowance)		34 or less (5.9 or less)	–
Oil pump pressure MPa	Oil pump relief pressure	9.8	–
	Pressure under no-load conditions	0.3–0.8	–
	Steering gear retention hydraulic pressure	9.8	–
Oil pressure switch operating pressure MPa	OFF→ON	1.8–2.4	–
	ON→OFF	1.0	–
Total pinion preload Nm (Change in torque: 0.4 Nm)		0.6–1.3	–
Tie-rod joint swing resistance N (Tie-rod joint swing torque Nm)		6–20 (1.5–4.9)	–

LUBRICANTS

37200040041

Items	Specified lubricant	Quantity
Power steering fluid	Automatic transmission fluid DEXRON or DEXRON II	As required
O-ring	Automatic transmission fluid DEXRON or DEXRON II	As required

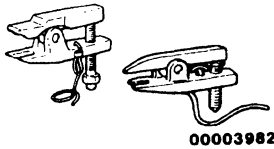

SPECIAL TOOLS

37200060054

Tool	Number	Name	Use
 <p>00003982</p>	MB991113 or MB990635	Steering linkage puller	Disconnection of tie-rod end

37A-4

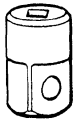
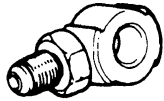
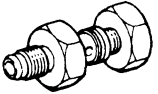
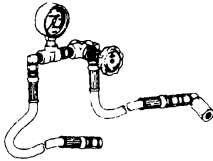
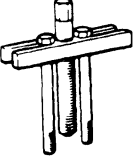
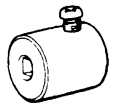
STEERING – Special Tools

Tool	Number	Name	Use
	MB990685	Torque wrench	<ul style="list-style-type: none"> • Measurement of the ball joint starting torque • Measurement of the pinion shaft preload
	MB990326	Preload socket	Measurement of the ball joint starting torque
	MB990993 or MB991217	Power steering oil pressure gauge adapter (pump side)	Measurement of oil pressure
	MB990994	Power steering oil pressure gauge adapter (hose side)	
	MB990662	Oil pressure gauge assembly	
	MB990803	Steering wheel puller	Disconnection of the steering wheel
	MB991006	Preload socket	Measurement of the pinion shaft preload
	MB990776	Front axle base	Installation of dust cover for tie rod end ball joint

ON-VEHICLE SERVICE

37200100046

STEERING WHEEL FREE PLAY CHECK

1. With engine running (hydraulic operation), set front wheels straight ahead.
2. Measure the play on steering wheel circumference before wheels start to move when slightly moving steering wheel in both directions.

Limit: 30 mm

3. When play exceeds the limit, check for play on steering shaft connection and steering linkage. Correct or replace.
4. If the free play still exceeds the limit value, set steering wheel straight ahead with engine stopped. Load 5 N towards steering wheel circumference and check play.

Standard value (steering wheel play with engine stopped): 10 mm or less

If the play exceeds the standard value, remove steering gear box and check total pinion torque.

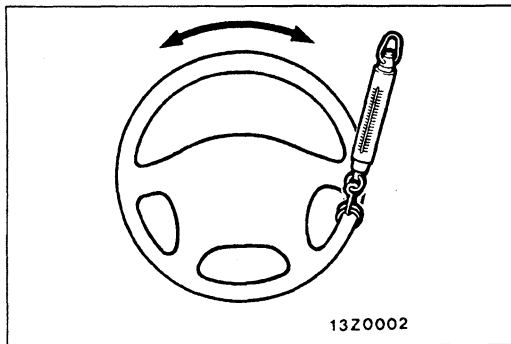

STEERING ANGLE CHECK

37200110056

1. Locate front wheels on turning radius gauge and measure steering angle.

Standard value:

Inner wheel $39^{\circ}00' \pm 1^{\circ}30'$

Outer wheel $32^{\circ}00'$

2. When the angle is not within the standard value, the toe is probably incorrect. Adjust toe (Refer to GROUP 33A – On-vehicle Service) and recheck steering angle.

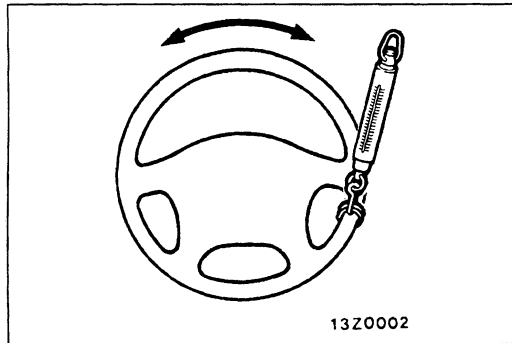
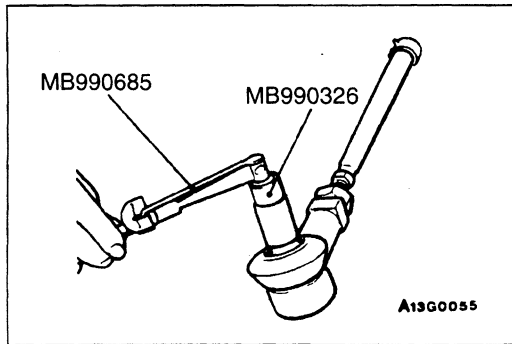
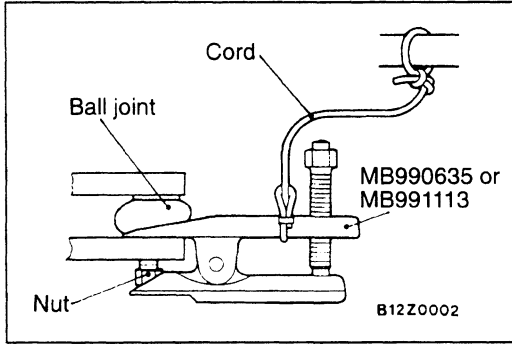

TIE ROD END BALL JOINT STARTING TORQUE CHECK

37200150058

1. Disconnect tie rod and knuckle with special tool.

Caution

1. Using the special tool, loosen the tie rod end mounting nut. Only loosen the nut; do not remove it from the ball joint.
2. Support the special tool with a cord, etc. to prevent it from coming off.

2. Move ball joint stud several times and install nut on stud. Measure ball joint starting torque with special tools.

Standard value: 1.0–3.0 Nm

3. When the starting torque exceeds the standard value, replace tie rod end.
4. When the starting torque is under the standard value, check ball joint for end play or ratcheting. If none of these, the joint is still serviceable.

STATIONARY STEERING EFFORT CHECK

37200170054

1. With the vehicle stopped on a flat, paved surface, turn the steering wheel to the straight ahead position.
2. Start the engine and set it to $1,000 \pm 100$ r/min.

Caution

After checking the engine r/min must be a return to the standard idling r/min.

3. Attach a spring balance to the outer circumference of the steering wheel and measure the steering force required to turn the steering wheel from the straight ahead position to the left and right (within a range of 1.5 turns). Also check to be sure that there is no significant fluctuation of the required steering force.

Standard value:

Steering effort: 34N or less

Fluctuation allowance: 5.9N or less

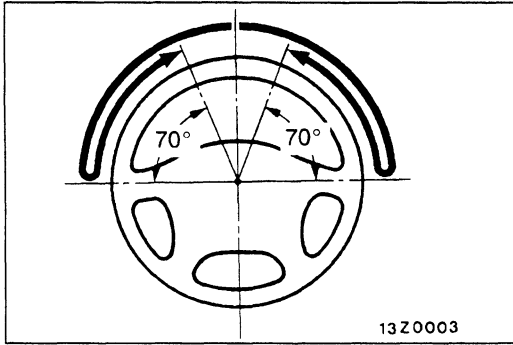

CHECKING STEERING WHEEL RETURN TO CENTRE

37200180057

To make this test, conduct a road test and check as follows.

1. Make both gradual and sudden turns and check the steering "feeling" to be sure that there is not difference in the steering force required and the wheel return between left and right turns.
2. At a speed of 35 km/h, turn the steering wheel 90° and release the steering wheel after 1 or 2 seconds. If the steering wheel then returns 70° or more, the return can be judged to be satisfactory.

NOTE

There will be a momentary feeling or "heaviness" when the wheel is turned quickly, but this is not abnormal. (This is because the oil pump discharge amount is especially apt to be insufficient during idling.)

DRIVE BELT TENSION CHECK

37200190029

Refer to GROUP 11A – On-vehicle Service.

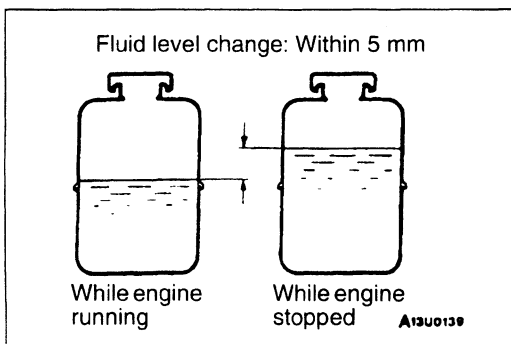

FLUID LEVEL CHECK

37200200043

1. Park the vehicle on a flat, level surface, start the engine, and then turn the steering wheel several times to raise the temperature of the fluid to approximately 50–60°C.
2. With the engine running, turn the wheel all the way to the left and right several times.
3. Check the fluid in the oil reservoir for foaming or milkiness. Check the difference of the fluid level when the engine is stopped, and while it is running. If the change of the fluid level is 5 mm or more, air bleeding should be done.

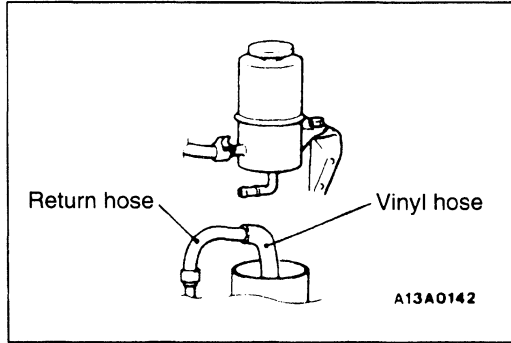

FLUID REPLACEMENT

37200210046

1. Raise the front wheels on a jack, and then support them with rigid racks.
2. Disconnect the return hose connection.
3. Connect a vinyl hose to the return hose, and drain the oil into a container.
4. Disconnect the high tension cable.

Caution

Be careful not to position the high-tension cable near the delivery pipe.

5. While operating the starting motor intermittently, turn the steering wheel all the way to the left and right several times to drain all of the fluid.
6. Connect the return hoses securely, and then secure it with the clip.
7. Fill the oil reservoir with the specified fluid up to the lower position of the filter, and then bleed the air.

Specified fluid:

**Automatic transmission fluid
DEXRON or DEXRON II**

BLEEDING

37200220049

1. Jack up the front wheels and support them by using a rigid rack.
2. Manually turn the oil pump pulley a few times.
3. Turn the steering wheel all the way to the left and to the right five or six times.
4. Disconnect the high-tension cable.

Caution

Be careful not to position the high-tension cable near the delivery pipe.

5. While operating the starting motor intermittently, turn the steering wheel all the way to the left and right five or six times (for 15 to 20 seconds).

Caution

1. During air bleeding, replenish the fluid supply so that the level never falls below the lower position of the filter.
 2. If air bleeding is done while engine is running, the air will be broken up and absorbed into the fluid; be sure to do the bleeding only while cranking.
6. Connect the ignition cable.
 7. Turn the steering wheel to the left and right until there are no air bubbles in the oil reservoir.
 8. Confirm that the fluid is not milky, and that the level is up to the specified position on the level gauge.
 9. Confirm that there is very little change in the fluid level when the steering wheel is turned left and right.

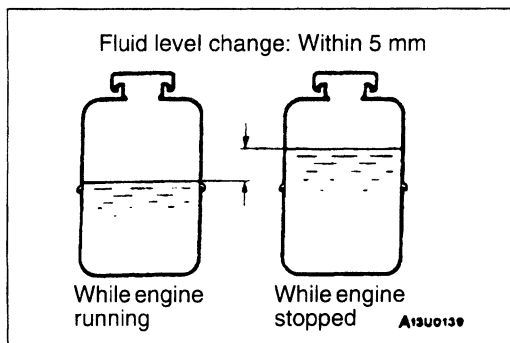

10. Check whether or not the change in the fluid level is within 5 mm when the engine is stopped and when it is running.
11. If the change of the fluid level is 5 mm or more, the air has not been completely bled from the system, and thus must be bled completely.

Caution

1. If the fluid level rises suddenly after the engine is stopped, the air has not been completely bled.
2. If air bleeding is not complete, there will be abnormal noises from the pump and the flow-control valve, and this condition could cause a lessening of the life of the pump, etc.

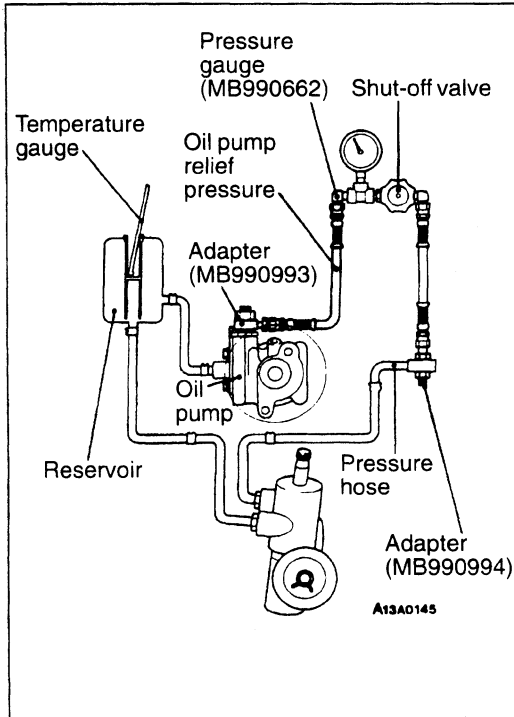

OIL PUMP PRESSURE TEST

37200230059

1. Disconnect the pressure hose from the oil pump, and then connect the special tools.
2. Bleed the air, and then turn the steering wheel several times while the vehicle is not moving so that the temperature of the fluid rises to approximately 50–60°C.
3. Start the engine and idle it at 1,000±100 r/min.
4. Fully close the shut-off valve of the pressure gauge and measure the oil pump relief pressure to confirm that it is within the standard value range.

Standard value: 9.8 MPa

Caution

Pressure gauge shut off valve must not remain closed for more than 10 seconds.

5. If it is not within the standard value, replace the oil pump.
6. Check whether or not the hydraulic pressure is the standard value when no-load conditions are created by fully opening the shut-off valve of the pressure gauge.

Standard value: 0.3–0.8 MPa

7. If it is not within the standard value, the probable cause is a malfunction of the oil line or steering gear box, so check these parts and repair as necessary.
8. Fully open the shut-off valve of the pressure gauge.
9. Turn the steering wheel all the way to the left or right; then check whether or not the retention hydraulic pressure is the standard value.

Standard value: 9.8 MPa

10. When not within the standard value, replace the power steering gear box.
Remeasure fluid pressure.
11. Remove the special tools, and then tighten the pressure hose to the specified torque.

Tightening torque: 44 Nm

12. Bleed the system.

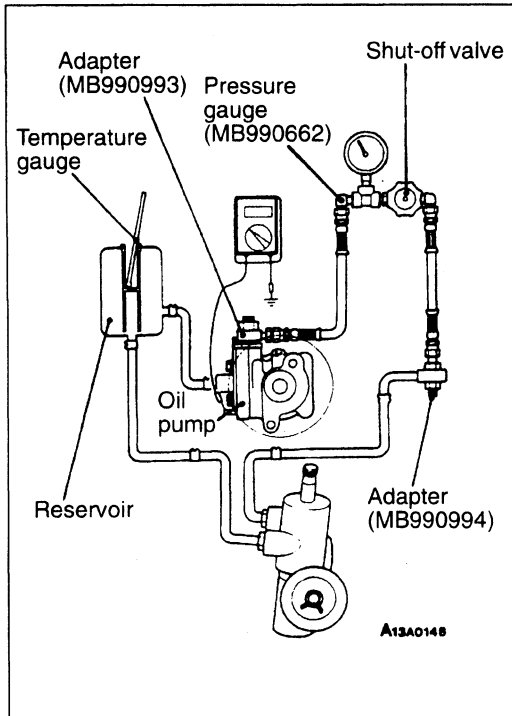

POWER STEERING OIL PRESSURE SWITCH CHECK

37200720037

1. Disconnect the pressure hose from the oil pump, and then connect the special tools.
2. Bleed the air, and then turn the steering wheel several times while the vehicle is not moving so that the temperature of the fluid rises to approximately 50–60°C.
3. The engine should be idling.
4. Disconnect the connection of the connector for the oil pressure switch, and place an ohmmeter in position.
5. Gradually close the shut-off valve of the pressure gauge and increase the hydraulic pressure, then check whether or not the hydraulic pressure that activates the switch is the standard value.

Standard value: 1.8–2.4 MPa

6. Gradually open the shut-off valve and reduce the hydraulic pressure; then check whether or not the hydraulic pressure that deactivates the switch is the standard value.

Standard value: 1.0 MPa

7. Remove the special tools, and then tighten the pressure hose to the specified torque.

Tightening torque: 44 Nm

8. Bleed the system.

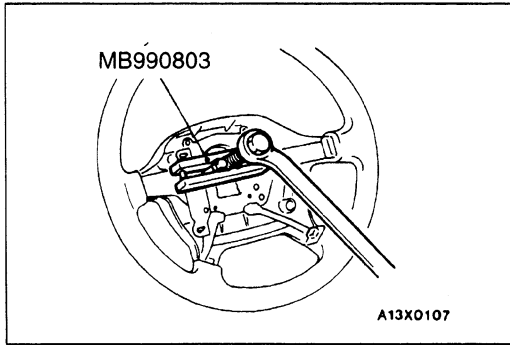

REMOVAL SERVICE POINT

◀A▶ STEERING WHEEL REMOVAL

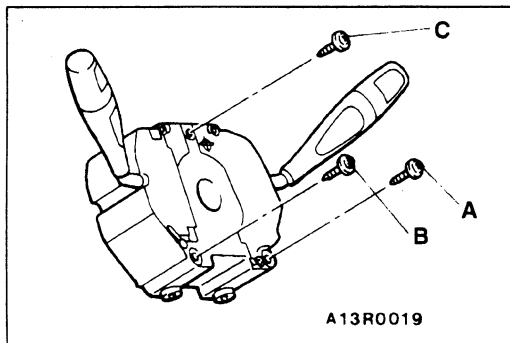

INSTALLATION SERVICE POINT

▶A◀ CLOCK SPRING AND COLUMN SWITCH/COLUMN SWITCH INSTALLATION

Tighten the screws in an alphabetical order.

DISASSEMBLY AND REASSEMBLY

37200280054

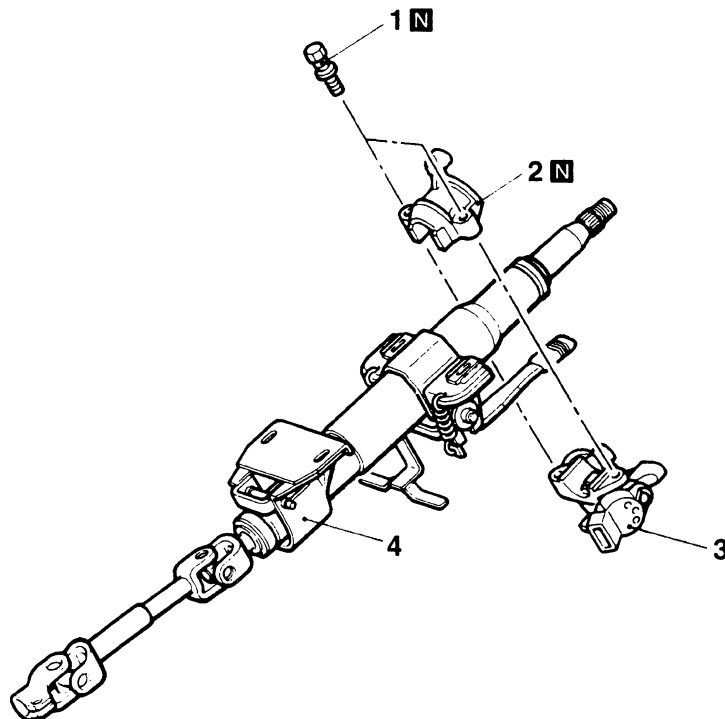

A13U0014

Disassembly steps

- ◀A▶ ▶A◀ 1. Special bolt
- ▶A◀ ▶A◀ 2. Steering lock bracket
- ▶A◀ ▶A◀ 3. Steering lock cylinder
- ▶A◀ ▶A◀ 4. Steering shaft

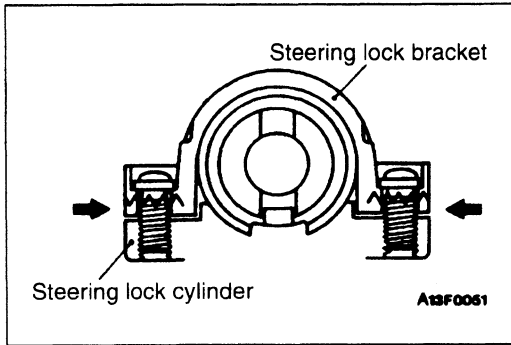

DISASSEMBLY SERVICE POINT

◀▶ STEERING LOCK BRACKET/STEERING LOCK CYLINDER REMOVAL

If it is necessary to remove the steering lock cylinder, use a hacksaw to cut the special bolts at the steering lock bracket side.

REASSEMBLY SERVICE POINT

▶◀ STEERING LOCK CYLINDER/STEERING LOCK BRACKET/SPECIAL BOLT INSTALLATION

- (1) When installing the steering lock cylinder and steering lock bracket to the column tube, temporarily install the steering lock in alignment with the column boss.

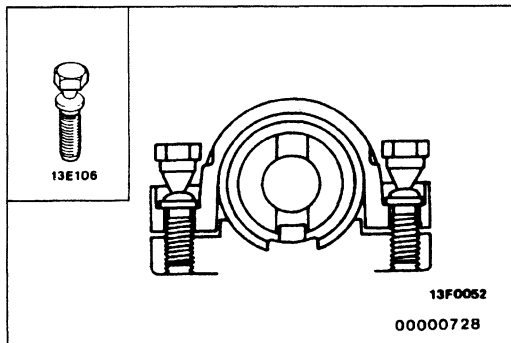

- (2) After checking that the lock works properly, tighten the special bolts until the head twists off.

Caution

The steering lock bracket and bolts must be replaced with new ones when the steering lock is installed.

POWER STEERING GEAR BOX

37200390054

REMOVAL AND INSTALLATION

CAUTION: SRS

For vehicles with SRS, before removal of steering gear box, refer to GROUP 52B, centre front wheels and remove ignition key. Failure to do so may damage SRS clock spring and render SRS system inoperative, risking serious driver injury.

Pre-removal Operation

- (1) Power Steering Fluid Draining (Refer to P.37A-8.)
- (2) Center Member Removal (Refer to GROUP 32.)
- (3) Front Exhaust Pipe Removal (Refer to GROUP 15.)

Post-installation Operation

- (1) Front Exhaust Pipe Installation (Refer to GROUP 15.)
- (2) Center Member Installation (Refer to GROUP 32.)
- (3) Power Steering Fluid Supplying (Refer to P.37A-8.)
- (4) Power Steering Fluid Line Bleeding (Refer to P.37A-8.)
- (5) Checking Steering Wheel Position with Wheels Straight Ahead
- (6) Front Wheel Alignment Adjustment (Refer to GROUP 33A.)

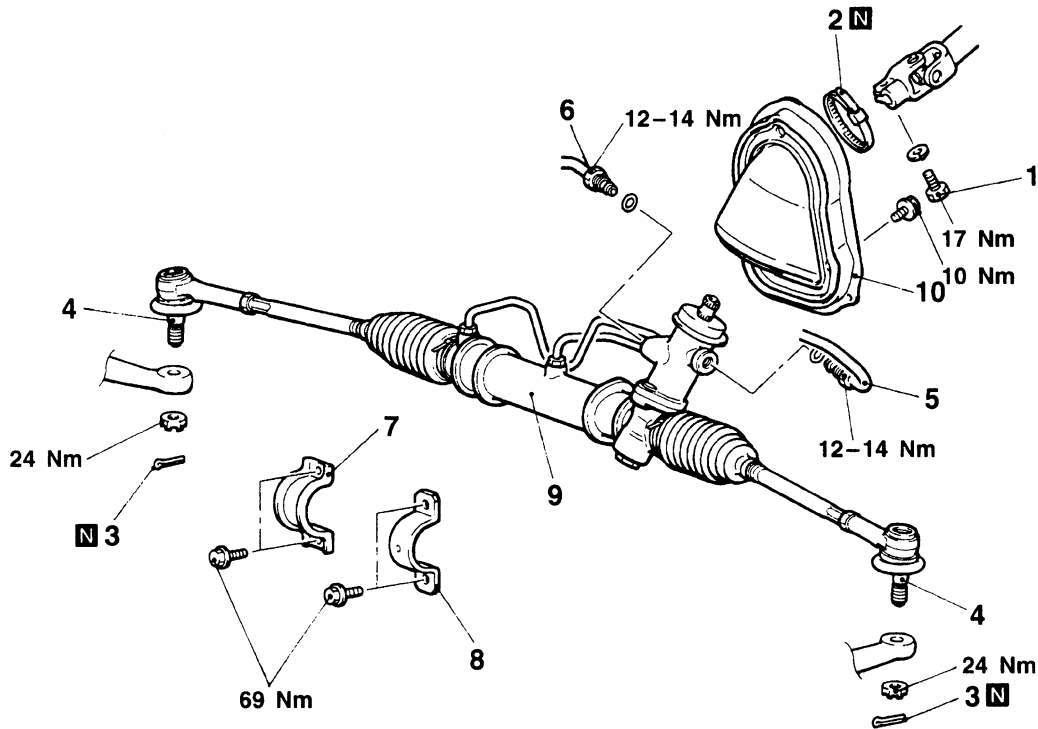

A13U0011

Removal steps

1. Steering shaft assembly and gear box connecting bolt
2. Band
3. Split pin
4. Tie-rod end and knuckle connection
5. Return hose connection

6. Pressure hose connection
7. Cylinder clamp
8. Gear housing clamp
9. Gear box assembly
10. Retainer assembly



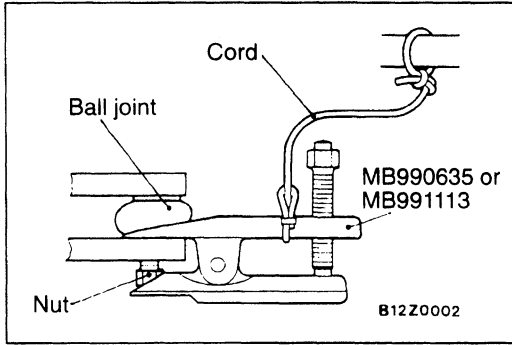

REMOVAL SERVICE POINTS

◀A▶ TIE-ROD END DISCONNECTION

Caution

1. Using the special tool, loosen the tie rod end mounting nut. Only loosen the nut; do not remove it from the ball joint.
2. Support the special tool with a cord, etc. to prevent it from coming off.

◀B▶ GEAR BOX ASSEMBLY REMOVAL

Caution

Be careful not to damage the bellows and the tie-rod end dust cover when removing the gear box assembly.

INSPECTION

37200400047

- Check the rubber parts for cracks and breakage.

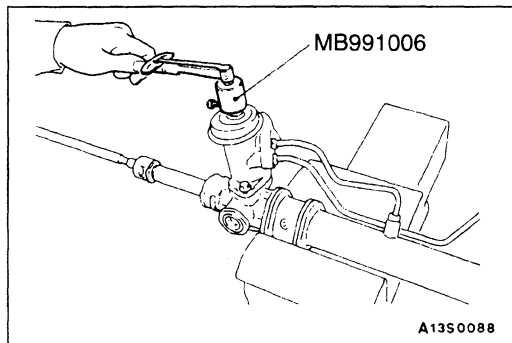

GEAR BOX TOTAL PINION TORQUE

Using the special tools, rotate the pinion gear at the rate of one rotation in approximately 4 to 6 seconds to check the total pinion torque.

Standard value: 0.6–1.3 Nm
[Change in torque: 0.4 Nm]

NOTE

When measuring, remove the bellows from the rack housing. Measure the pinion torque through the whole stroke of the rack.

If the measured value is not within the standard range, first adjust the rack support cover, and then check the total pinion starting torque again.

If the torque cannot be adjusted to the standard value, replace the power steering gear box assembly.

Caution

The power steering gear box assembly should be secured at the mounting sections. If it is secured in any other places, the gear housing may become deformed or damaged.

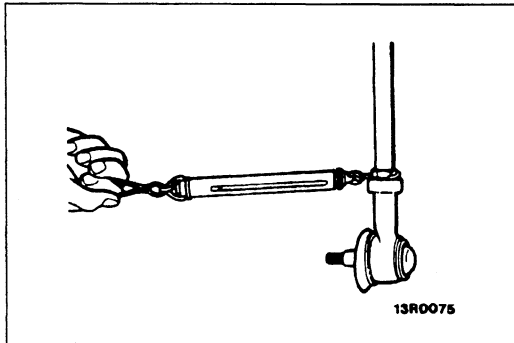

CHECK THE TIE ROD FOR SWING RESISTANCE

- (1) Give 10 hard swings to the tie rod.
- (2) Measure the tie rod swing resistance with a spring balance.

Standard value: 6–20 N [1.5–4.9 Nm]

- (3) If the measured value exceeds the standard value, replace gear box assembly.
- (4) Even if the measured value is below the standard value, the tie rod which swings smoothly without excessive play may be used.

DISASSEMBLY AND REASSEMBLY

37200410057

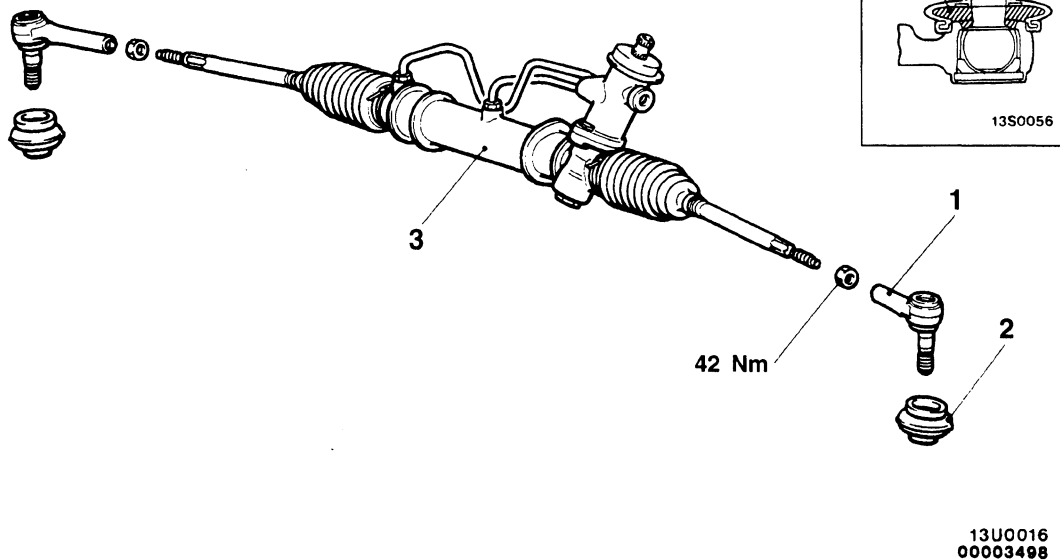

13U0016
00003498

Disassembly steps

- ▶C◀ 1. Tie rod end
- ▶B◀ 2. Dust cover
- ▶A◀ 3. Gear box assembly
- Total pinion torque adjustment

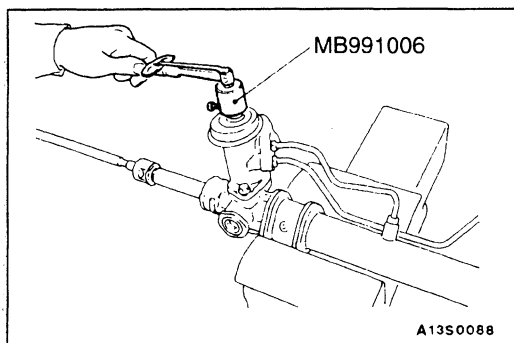

REASSEMBLY SERVICE POINTS

▶A◀ TOTAL PINION TORQUE ADJUSTMENT

- (1) Position rack at its centre. Tighten rack support cover to 15 Nm.
- (2) In neutral position, rotate pinion shaft clockwise one turn/4–6 seconds with special tool. Return rack support cover 30°–60° and adjust torque to the standard value.

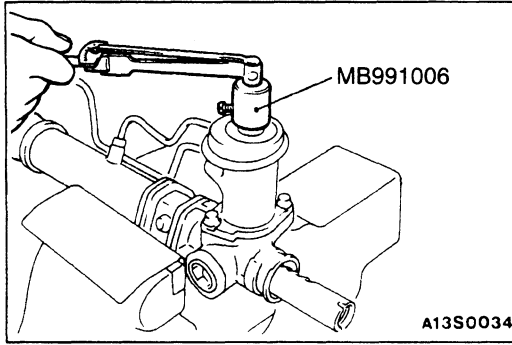

- (3) Using the special tools, rotate the pinion gear at the rate of one rotation in approximately 4 to 6 seconds to check the total pinion torque.

Standard value: 0.6–1.3 Nm
[Change in torque: 0.4 Nm]

Caution

1. When adjusting, set the standard value at its highest value.
2. Assure no ratcheting or catching when operating rack towards the shaft direction.

NOTE

When it cannot be adjusted within the specified return angle, check rack support cover components or replace.

- (4) After adjusting, lock rack support cover with lock nut.

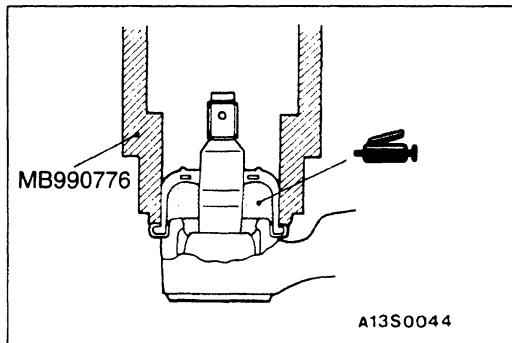

►B◄ DUST COVER INSTALLATION

- (1) Pack dust cover interior with multipurpose grease.
- (2) Apply specified sealant to dust cover lip.
Specified fluid: 3M ATD Part No. 8661 or equivalent
- (3) Using the special tool, install the dust cover to the tie rod end ball joint.

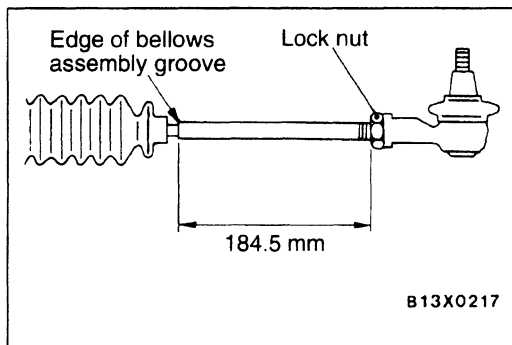

►C◄ TIE ROD END INSTALLATION

Screw in tie-rod end to have its right and left length as illustrated. Lock with lock nut.

POWER STEERING OIL PUMP

37200520057

REMOVAL AND INSTALLATION

Pre-removal Operation

- Power Steering Fluid Draining (Refer to P.37A-8.)

Post-installation Operation

- Power Steering Fluid Supplying (Refer to P.37A-8.)
- Drive-belt Tension Adjusting (Refer to P.37A-7.)
- Power Steering Fluid Line Bleeding (Refer to P.37A-8.)
- Oil Pump Pressure Check (Refer to P.37A-10.)

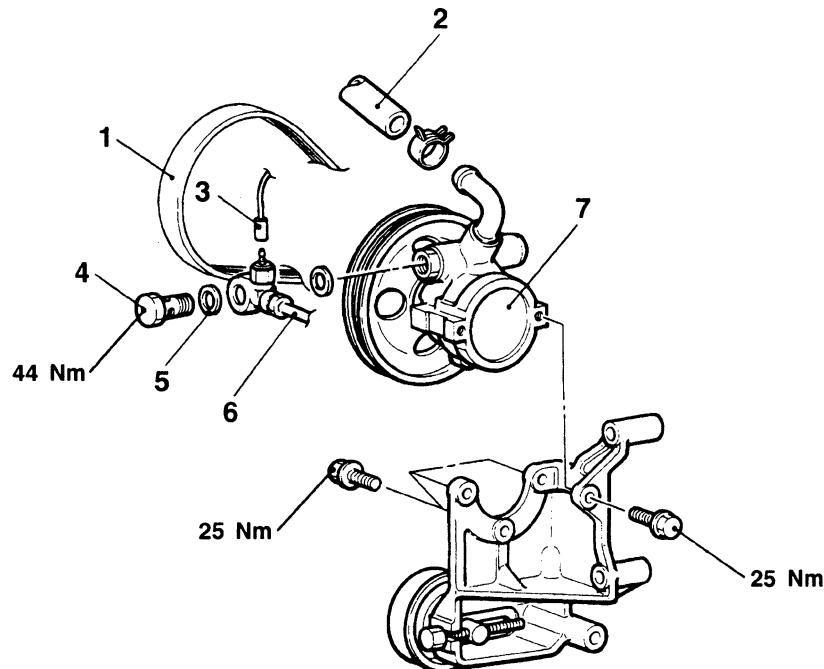

A13U0013

Removal steps

- | | |
|------------------------------|----------------|
| 1. Drive-belt | 5. Washer |
| 2. Suction hose | 6. Banjo block |
| 3. Pressure switch connector | 7. Oil Pump |
| 4. Eye bolt | |

INSPECTION

37200530036

- Check the drive-belt for cracks.
- Check the pulley assembly for uneven rotation.

POWER STEERING HOSES

37200570069

REMOVAL AND INSTALLATION

Pre-removal Operation

- Power Steering Fluid Draining (Refer to P.37A-8.)

Post-installation Operation

- Power Steering Fluid Supplying (Refer to P.37A-8.)
- Power Steering Fluid Line Bleeding (Refer to P.37A-8.)

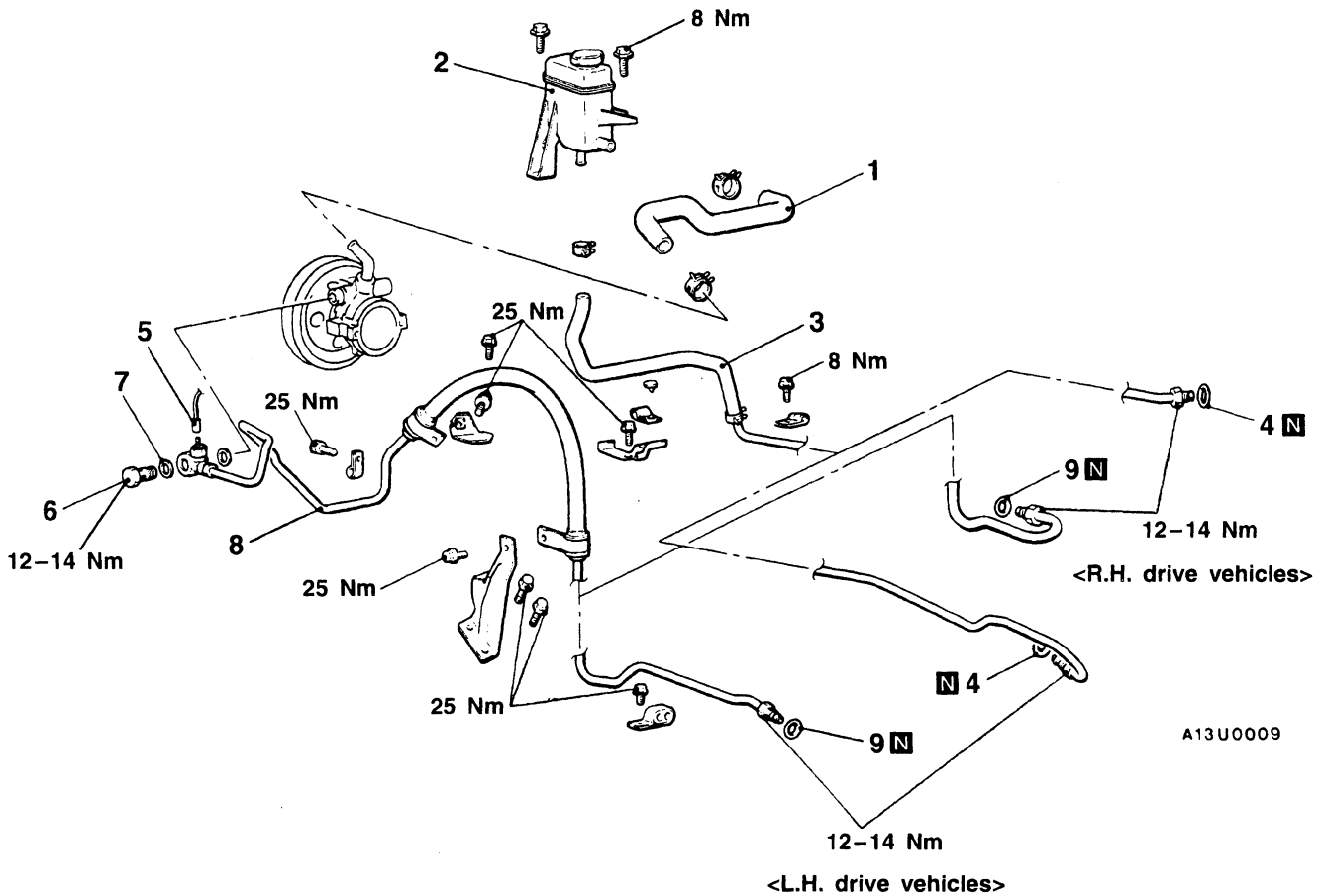

Removal steps

- ▶◀ 1. Suction hose
- ▶◀ 2. Oil reservoir
- ▶◀ 3. Return hose
- ▶◀ 4. O-ring
- ▶◀ 5. Pressure switch connector

- 6. Eye bolt
- 7. Washer
- 8. Pressure hose
- 9. O-ring

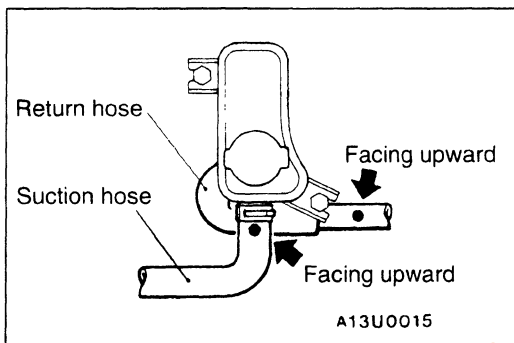

INSTALLATION SERVICE POINT

▶◀ RETURN HOSE/SUCTION HOSE INSTALLATION

Connect the hose so that the marking is facing upwards.