FRONT SUSPENSION

CONTENTS

3310900018

GENERAL INFORMATION	2	STRUT ASSEMBLY	7
SERVICE SPECIFICATIONS	3	LOWER ARM	10
SPECIAL TOOLS	4	STABILIZER BAR	12
ON-VEHICLE SERVICE	5		
Front Wheel Alignment Check and Adjustment	5		

33A-2

FRONT SUSPENSION – General Information

GENERAL INFORMATION

33100010010

The front suspension is a Mcpherson strut with coil spring. The shock absorber is hydraulic double-acting type.

COIL SPRING

Items	1600		1800	
	M/T	A/T	M/T	A/T
Wire dia. × O.D. × free length mm	12×138×328	13×138×334	13×160×344	13×160×351

CONSTRUCTION DIAGRAM

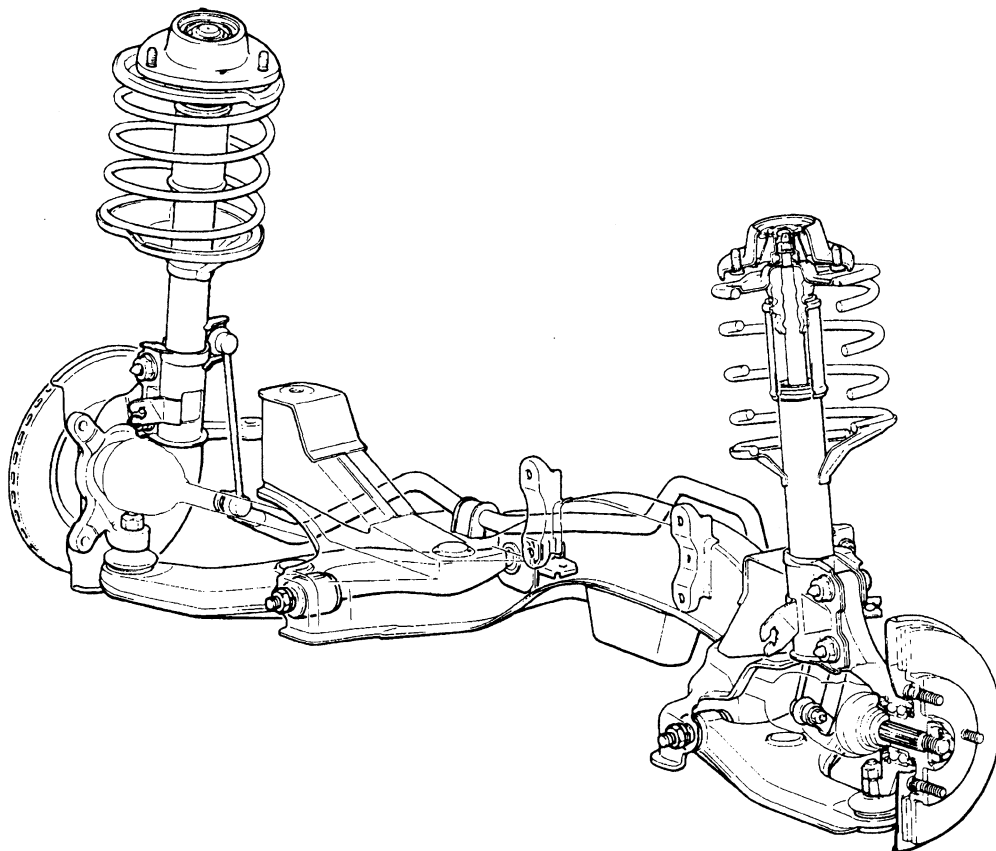

12U0006



SERVICE SPECIFICATIONS

33100030016

Items		Standard value
Toe-in	At the centre of tyre tread mm	1±2
	Toe-angle (per wheel)	0° 03'±06'
Toe-out angle on turns (inner wheel when outer wheel at 20°)		21.8°
Steering angle	Inner wheel	39°00'±1°30'
	Outer wheel	32°00'
Camber		0° 00'±30'
Caster		2° 12'
Kingpin inclination		12° 41'
Lower arm ball joint starting torque Nm		1.0–6.5
Lower arm ball joint turning torque Nm		1.0–3.9
Stabilizer link ball joint turning torque Nm		1.7–3.1

SPECIAL TOOLS

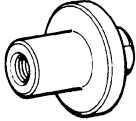
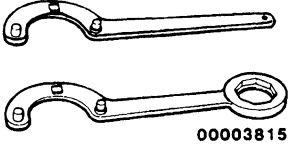
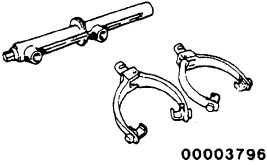
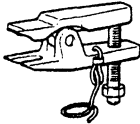
33100060015

Tools	Number	Name	Use
	MB991004	Wheel alignment gauge attachment	Measurement of the wheel alignment
	MB990278 or MB990775	Special spanner	Disassembly/assembly of the strut assembly
	MB991237 MB991238	Spring compressor body Arm set	Compression of the front coil spring
	MB991113	Steering linkage puller	Removal of the ball joint
	MB990326	Preload socket	Measurement of the ball joint rotation starting torque and turning torque
	MB990968	Torque wrench	

ON-VEHICLE SERVICE

33100090045

FRONT WHEEL ALIGNMENT CHECK AND ADJUSTMENT

Measure the wheel alignment with the vehicle parked on a level surface.

The front suspension, steering system, and wheels should be serviced to normal condition prior to measurement of wheel alignment.

TOE-IN

Standard value:

At the centre of tyre tread 1 ± 2 mm

Toe angle (per wheel) $0^{\circ}03' \pm 06'$

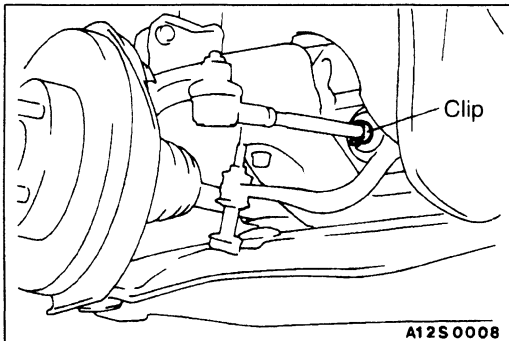

NOTE

1. If the toe-in is not within the standard value, adjust the toe-in by undoing the clips and turning the left and right tie rod turn buckles by the same amount (in opposite directions).
2. The toe will move out as the left turnbuckle is turned toward the front of the vehicle and the right turnbuckle is turned toward the rear of the vehicle.
For each one turn of the left and right tie rods, the toe-in will be adjusted by approx. $0^{\circ}35'$ (per wheel).

TOE-OUT ANGLE ON TURNS

To check the steering linkage, especially after the vehicle has been involved in an accident or if an accident is presumed, it is advisable to check the toe-out angle on turns in addition to the wheel alignment.

Conduct this test on the left turn as well as on the right turn.

Standard value:

21.8° (inner wheel when outer wheel at 20°)

STEERING ANGLE

Standard value:

Inner wheel $39^{\circ}00' \pm 1^{\circ}30'$

Outer wheel $32^{\circ}00'$

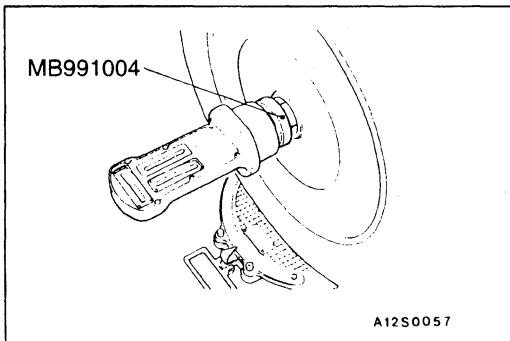

CAMBER, CASTER AND KINGPIN INCLINATION

Standard value:

Camber $0^{\circ}00' \pm 30'$

Caster $2^{\circ}12'$

Kingpin inclination $12^{\circ}41'$

NOTE

1. Camber and caster are preset at the factory and cannot be adjusted.
2. If camber is not within the standard value, check and replace bent or damaged parts.
3. For vehicles with aluminium type wheels, attach the camber/caster/kingpin gauge to the drive shaft by using the special tool. Tighten the special tool to the same torque 200–260 Nm as the drive shaft nut.

Caution

Never subject the wheel bearings to the vehicle load when the drive shaft nuts are loosened.

STRUT ASSEMBLY

33200110027

REMOVAL AND INSTALLATION

Post-installation Operation

- Front Wheel Alignment Adjustment (Refer to P.33A-5.)

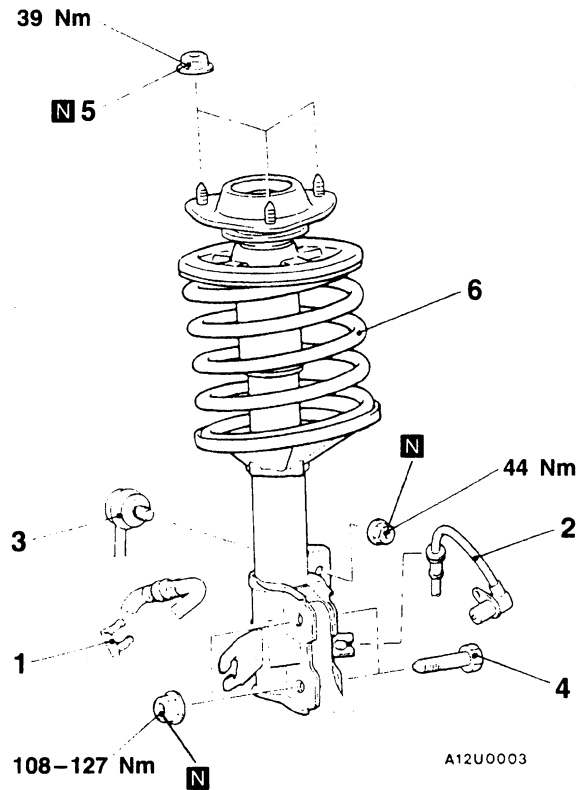

Removal steps

1. Brake hose clamp
2. Front speed sensor <Vehicles with ABS>
3. Stabilizer link



4. Bolts
5. Self locking nut
6. Strut assembly

REMOVAL SERVICE POINT

◀A▶ BOLTS REMOVAL

- (1) Suspend the lower arm from the vehicle with wire.
- (2) Remove the strut and knuckle connection.

INSPECTION

33200120020

- Check for oil leaks from the strut assembly.
- Check the strut assembly for damage or deformation

DISASSEMBLY AND REASSEMBLY

33200130030

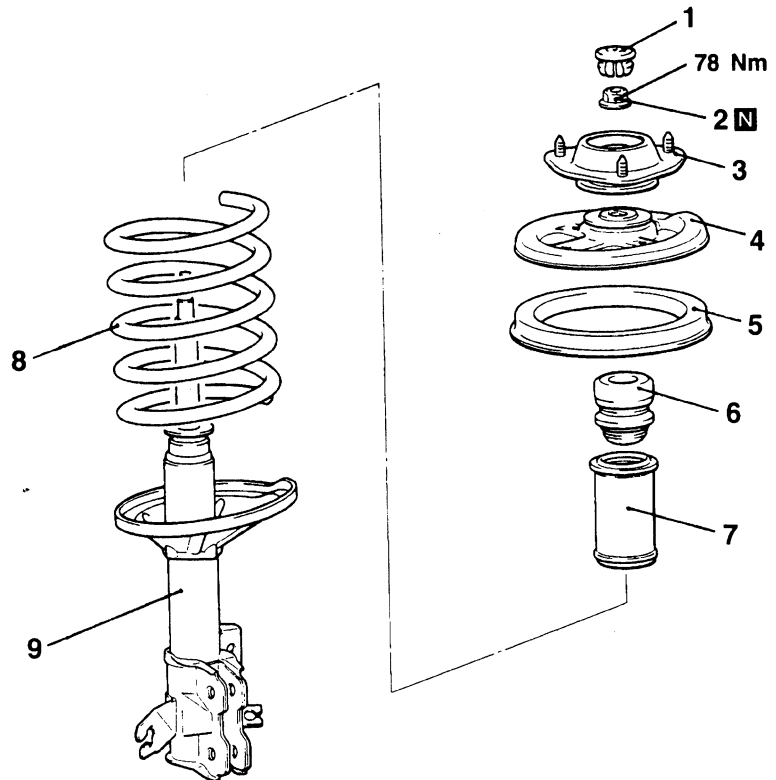
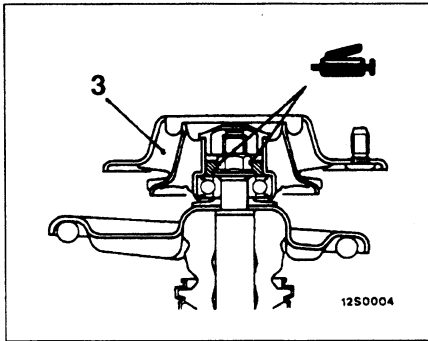

12U0001
00003468

Disassembly steps



1. Dust cover
2. Self locking nut
3. Strut insulator
4. Spring seat, upper
5. Spring pad, upper

6. Bump rubber
7. Dust cover
8. Coil spring
9. Strut assembly

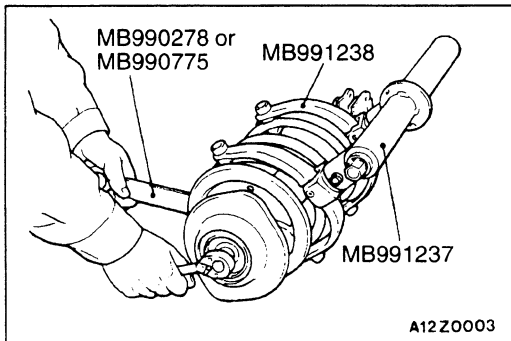

DISASSEMBLY SERVICE POINTS

◀A▶ SELF LOCKING NUT REMOVAL

- (1) Using the special tools, compress the coil spring.

NOTE

Install the special tools evenly, and so that the maximum length will be attained within the installation range.

Caution

Do not use an impact wrench to tighten the special tool bolt.

- (2) Holding the spring upper seat with the special tool, loosen the self locking nut.

Caution

Do not use an impact wrench.

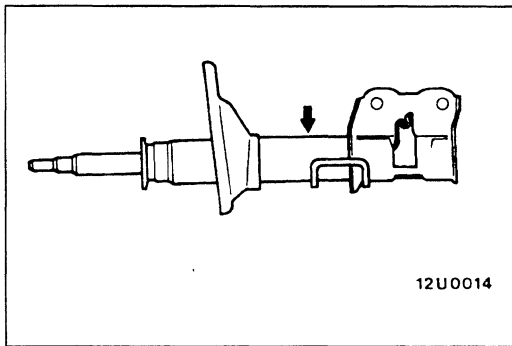

◀B▶ STRUT ASSEMBLY REMOVAL

To discard the strut assembly, place the assembly horizontally with its piston rod extended. Then drill a hole approx. 3 mm in diameter at the location shown in the illustration and discharge the gas.

Caution

The gas itself is harmless but it may issue out of the hole together with chips generated by the drill. Therefore, be sure to wear goggles.

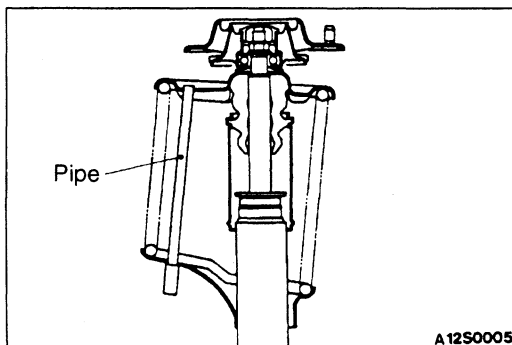

REASSEMBLY SERVICE POINT

▶A◀ SELF LOCKING NUT INSTALLATION

- (1) With the coil spring held compressed by the special tools (MB991237 and MB991238), provisionally tighten the self locking nut.

Caution

Do not use an impact wrench to tighten the special tool bolt.

- (2) Line up the holes in the strut assembly spring lower seat with the hole in the spring upper seat.

NOTE

The job is easily accomplished with a pipe.

- (3) Correctly align both ends of the coil spring with the grooves in the spring seat, and then loosen the special tools (MB991237 and MB991238).
- (4) Using the special tool, tighten the self locking nut to the specified torque.

Caution

Do not use an impact wrench.

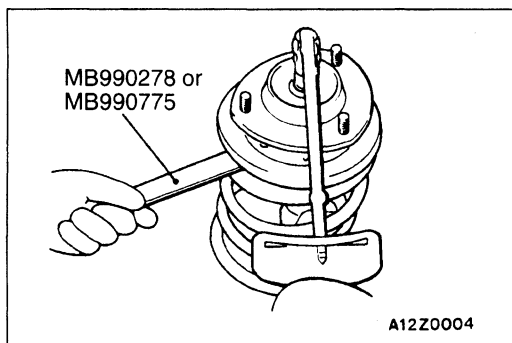

- (5) Apply multipurpose grease to the bearing part of the strut insulator.

Caution

When applying the grease, take care that grease does not adhere to the insulator's rubber part.

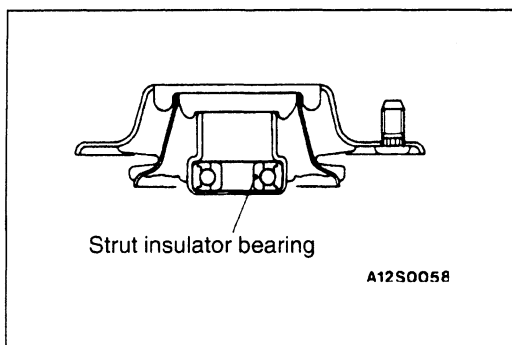

INSPECTION

33200140026

- Check the strut insulator bearing for wear or rust.
- Check the rubber parts for damage or deterioration.
- Check the spring for deformation, deterioration or damage.
- Check the shock absorber for deformation.

LOWER ARM

33200160022

REMOVAL AND INSTALLATION

Post-installation Operation

- Front Wheel Alignment Adjustment (Refer to P.33A-5.)

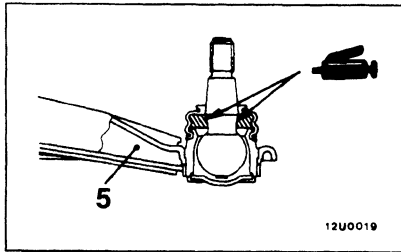

59-71 Nm

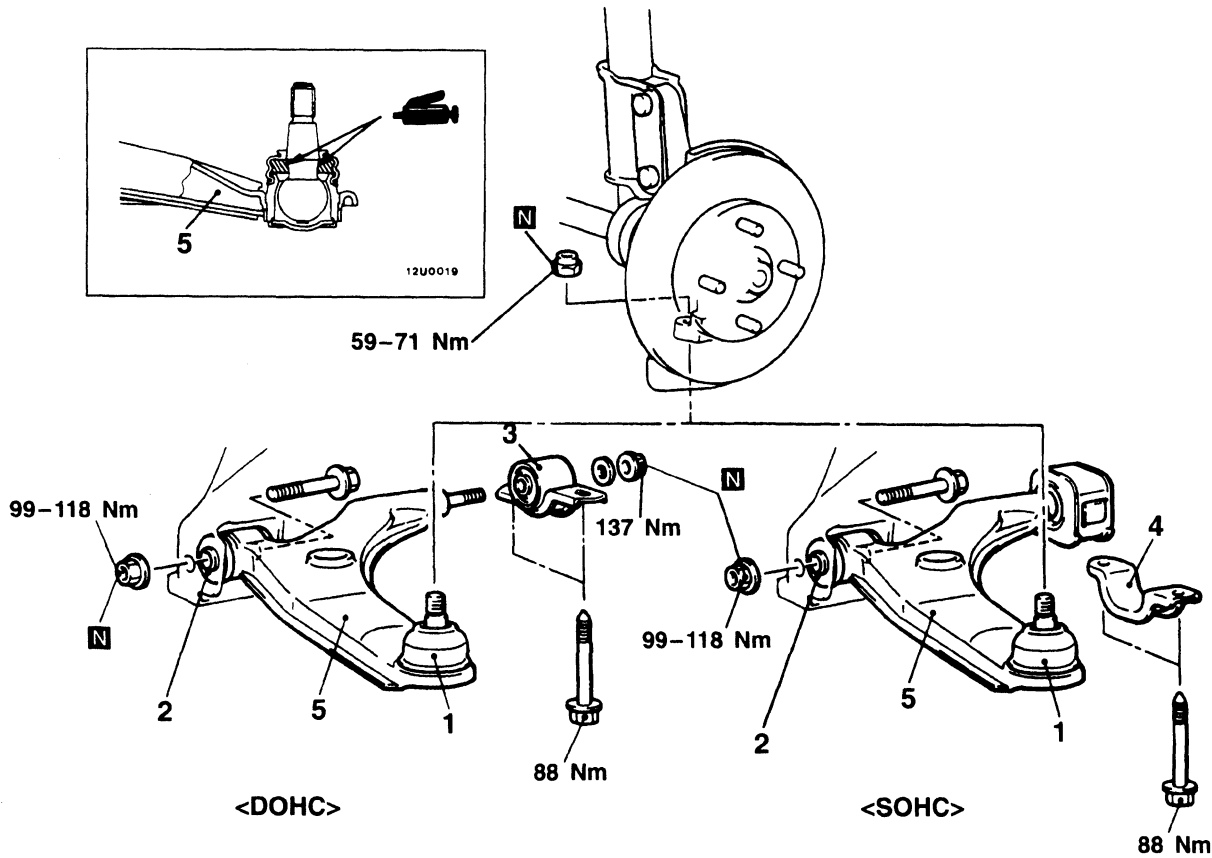

<DOHC>

<SOHC>

88 Nm

12U0017
00003469

Removal steps



1. Lower arm ball joint connection
2. Lower arm front bushing connection
3. Lower arm rear bushing <DOHC>
4. Support bracket <SOHC>
5. Lower arm assembly

REMOVAL SERVICE POINT

◀▶ LOWER ARM BALL JOINT DISCONNECTION

Using the special tool, disconnect the lower arm ball joint from the knuckle.

Caution

1. Be sure to tie the cord of the special tool to a nearby part.
2. Loosen the nut but do not remove it.

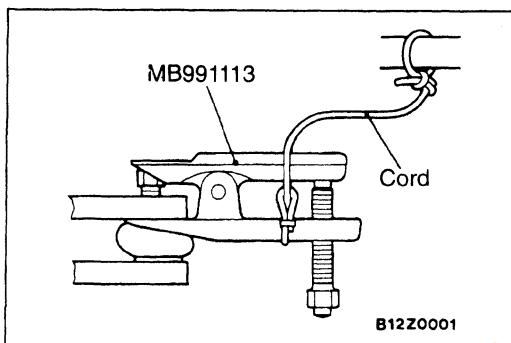

INSPECTION

33200170025

- Check the bushing for wear and deterioration.
- Check the lower arm for bend or breakage.
- Check the support bracket for deterioration or damage.
- Check the ball joint dust cover for cracks.
- Check all bolts for condition and straightness.

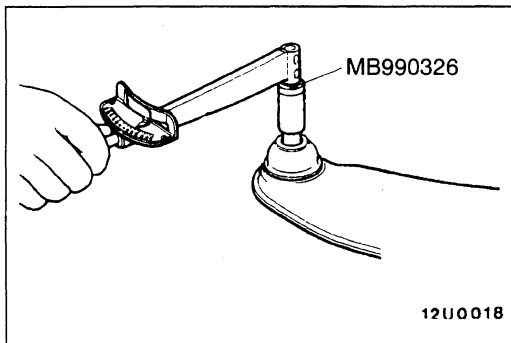

BALL JOINT STARTING TORQUE/TURNING TORQUE CHECK

- (1) After shaking the ball joint stud several times, install the nut to the stud and use the special tool to measure the starting/turning torque of the ball joint.

Standard value:

Starting torque 1.0–6.5 Nm

Turning torque 1.0–3.9 Nm

- (2) If the measured values exceed the standard values, replace the ball joint.
- (3) If the measured values are lower than the standard values, check that the ball joint does not feel stiff. If it doesn't feel stiff, it is possible to use the ball joint.

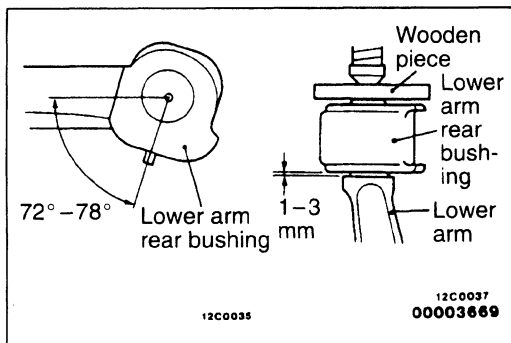

LOWER ARM REAR BUSHING REPLACEMENT <SOHC>

- (1) Apply soapy water between the shaft and old bushing, and pry up bushing using a screwdriver.
- (2) Apply soapy water to the shaft and new bushing and install new bushing into the shaft at the angle shown in the illustration.
- (3) Press in the bushing as illustrated.

STABILIZER BAR

33200190014

REMOVAL AND INSTALLATION

Pre-removal and Post-installation Operation

- Cross-member Removal and Installation
(Refer to GROUP 32 – Cross-member.)

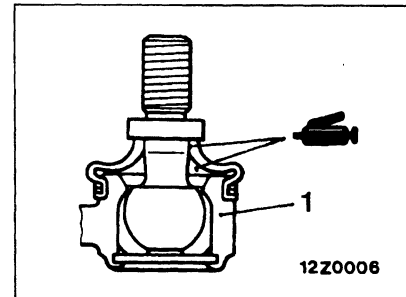
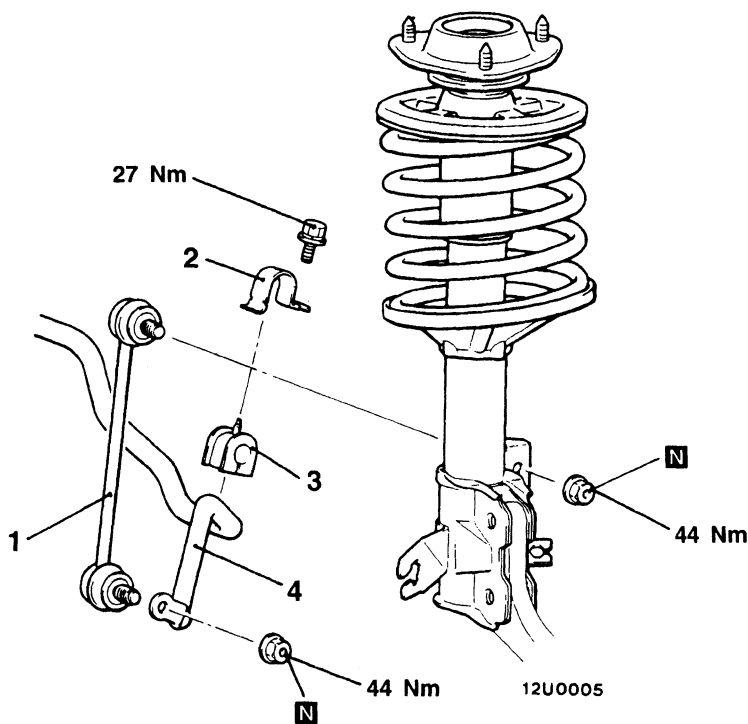

00003470

Removal steps

1. Stabilizer link
2. Fixture
3. Bush
4. Stabilizer bar

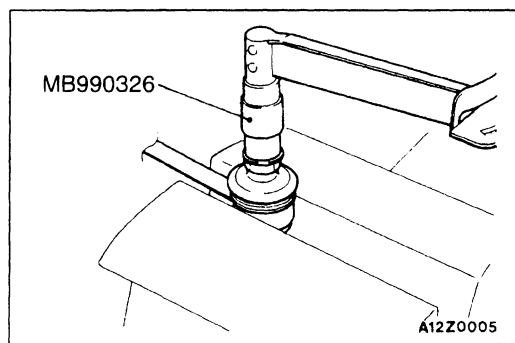

INSPECTION

33200200014

STABILIZER LINK BALL JOINT TURNING TORQUE INSPECTION

- (1) Shake the stabilizer link ball joint stud several times before installing the nut to the stud. Then use the special tool to measure the turning torque of the stabilizer link ball joint.

Standard value: 1.7–3.1 Nm

- (2) If the turning torque exceeds the standard value, replace the stabilizer link.
- (3) If the turning torque is lower than the standard value, check that the ball joint does not feel stiff. If it doesn't feel stiff, it is possible to use the ball joint.

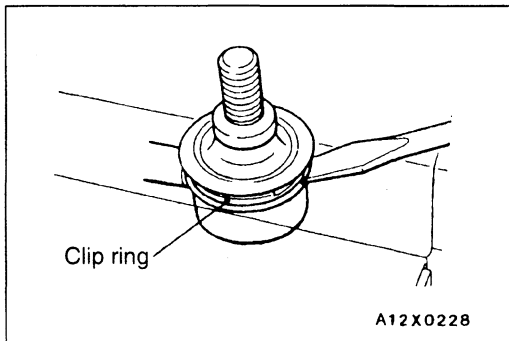

STABILIZER LINK DUST COVER REPLACEMENT

- (1) Remove the clip ring and the dust cover.

Caution

Do not damage the dust cover.

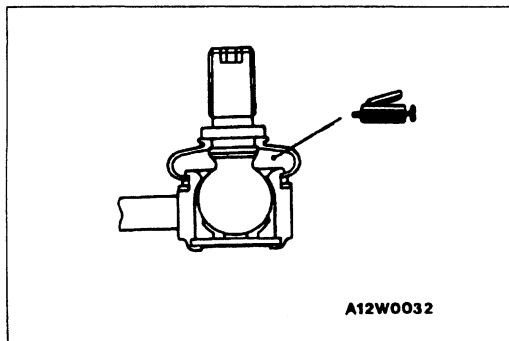

- (2) Apply multipurpose grease to inside of the dust cover.

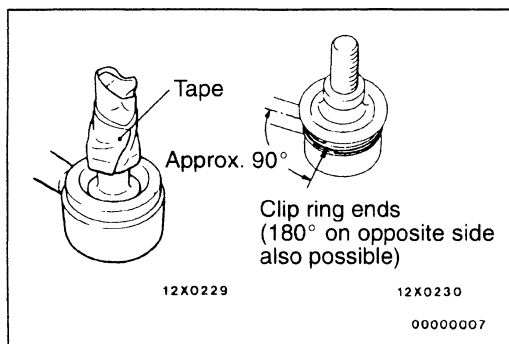

- (3) Use vinyl tape to tape the stabilizer link where shown in the illustration, and then install the dust cover to the stabilizer link.

- (4) Secure the dust cover by the clip ring.

NOTE

When installing the clip ring, align it so that its ends are located at a 90° angle from the axis of the stabilizer link.

NOTES