

ENGINE AND EMISSION CONTROL

CONTENTS

1710900018

ENGINE CONTROL SYSTEM	3	AUTO-CRUISE CONTROL SYSTEM ..	5
GENERAL INFORMATION	3	GENERAL INFORMATION	5
SERVICE SPECIFICATIONS	3	SERVICE SPECIFICATIONS	5
ON-VEHICLE SERVICE	3	SPECIAL TOOL	5
Accelerator Cable Check and Adjustment ...	3	TROUBLESHOOTING	6
ACCELERATOR CABLE AND PEDAL	4		

CONTINUED ON NEXT PAGE

WARNINGS REGARDING SERVICING OF SUPPLEMENTAL RESTRAINT SYSTEM (SRS) EQUIPPED VEHICLES

WARNING!

- (1) Improper service or maintenance of any component of the SRS, or any SRS-related component, can lead to personal injury or death to service personnel (from inadvertent firing of the air bag) or to the driver and passenger (from rendering the SRS inoperative).
- (2) Service or maintenance of any SRS component or SRS-related component must be performed only at an authorized MITSUBISHI dealer.
- (3) MITSUBISHI dealer personnel must thoroughly review this manual, and especially its GROUP 52B – Supplemental Restraint System (SRS) before beginning any service or maintenance of any component of the SRS or any SRS-related component.

NOTE

The SRS includes the following components: SRS-ECU, SRS warning lamp, air bag module, clock spring and interconnecting wiring. Other SRS-related components (that may have to be removed/installed in connection with SRS service or maintenance) are indicated in the table of contents by an asterisk (*)

ON-VEHICLE SERVICE	23	PCV Valve Check	37
Auto-cruise Control Cable Check and Adjustment	23	EVAPORATIVE EMISSION CONTROL SYSTEM	38
Auto-cruise Control Main Switch Check	24	General Information	38
Auto-cruise Control Switch Check	25	System Diagram	38
Auto-cruise Control Component Check	26	Component Location	38
AUTO-CRUISE CONTROL*	28	Purge Control System Check	39
EMISSION CONTROL SYSTEM	32	Purge Port Vacuum Check	39
GENERAL INFORMATION	32	Purge Control Solenoid Valve Check	40
Emission Control Device Reference Table ..	32	EXHAUST GAS RECIRCULATION (EGR) SYSTEM	41
SERVICE SPECIFICATIONS	33	General Information	41
VACUUM HOSE	33	Operation	41
Vacuum Hose Piping Diagram	33	System Diagram	41
Vacuum Circuit Diagram	34	Component Location	41
Vacuum Hose Check	36	Exhaust Gas Recirculation (EGR) Control system Check	42
Vacuum Hose Installation	36	EGR Valve Check	42
CRANKCASE EMISSION CONTROL SYSTEM	36	EGR Port Vacuum Check	43
General Information	36	EGR Control Solenoid Valve Check	44
System Diagram	36	CATALYTIC CONVERTER	45
Component Location	37	General Information	45
Positive Crankcase Ventilation System Check	37	CANISTER	46

ENGINE CONTROL SYSTEM

17100010027

GENERAL INFORMATION

A cable-type accelerator mechanism and a suspended-type pedal have been adopted.

SERVICE SPECIFICATIONS

17100030030

Items		Standard value
Accelerator cable play mm		1-2
Engine idle speed r/min	4G92	750±50
	4G93	800±50

ON-VEHICLE SERVICE

17100090052

ACCELERATOR CABLE CHECK AND ADJUSTMENT

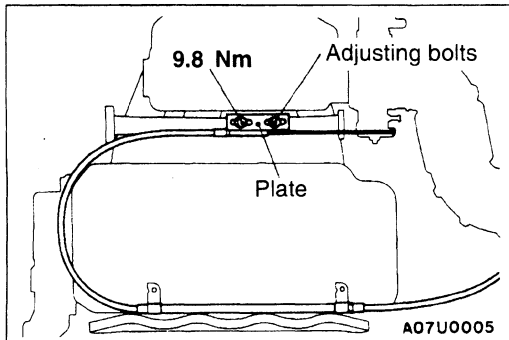

1. Turn A/C and lamps OFF.
Inspect and adjust at no load.
2. Warm engine until stabilized at idle.
3. Confirm idle speed is at prescribed value.

Standard value:

<4G92> 750±50 r/min

<4G93> 800±50 r/min

4. Stop engine (ignition switch OFF).
5. Confirm there are no sharp bends in accelerator cable.
6. Check inner cable for correct slack.

Standard value: 1-2 mm

7. If there is too much slack or no slack, adjust play by the following procedures.
 - (1) Loosen the adjusting bolt to release the cable.
 - (2) Move the plate until the inner cable play is at the standard value, and then tighten the adjusting bolt to the specified torque.

**ACCELERATOR CABLE AND PEDAL
REMOVAL AND INSTALLATION**

17100120058

Post-installation Operation

- Adjusting the Accelerator Cable (Refer to P.17-3.)

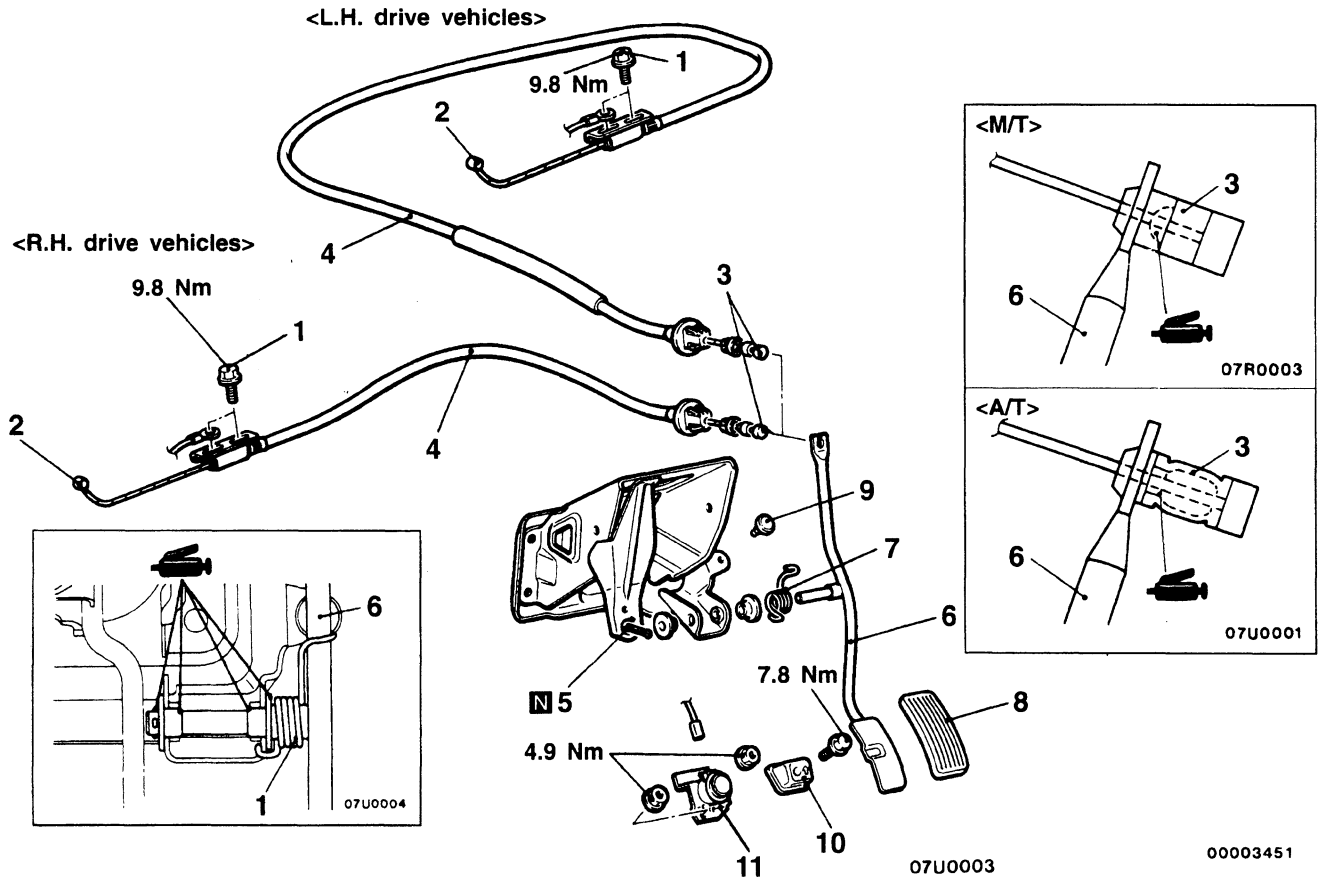

Removal steps

1. Adjusting bolts
2. Inner cable connection (Throttle body side)
3. Inner cable connection (Accelerator pedal side)
4. Accelerator cable
5. Split pin
6. Accelerator pedal
7. Spring
8. Pedal pad
9. Stopper
10. Accelerator pedal stopper <M/T>
11. Kick down switch <A/T>

AUTO-CRUISE CONTROL SYSTEM

17200010044

GENERAL INFORMATION

By using the auto-cruise control, the driver can drive at the speed he/she likes (in a range of

approximately 40–20 km/h) without depressing the accelerator pedal.

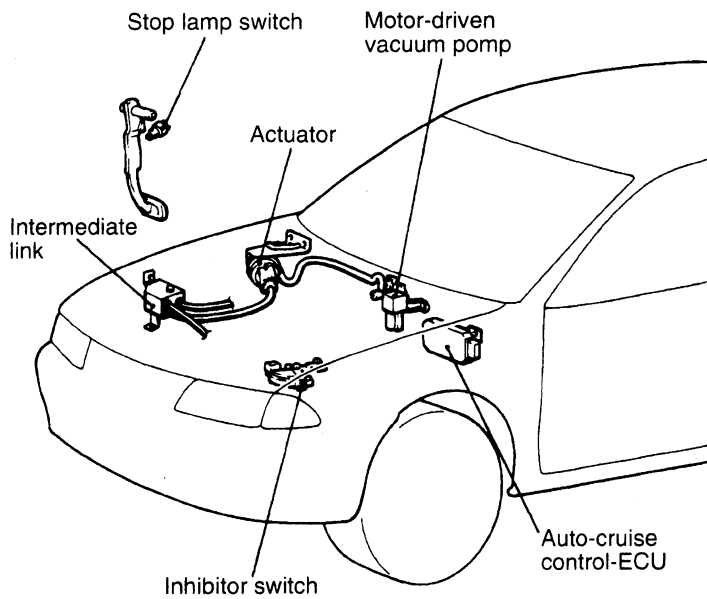

03U0005

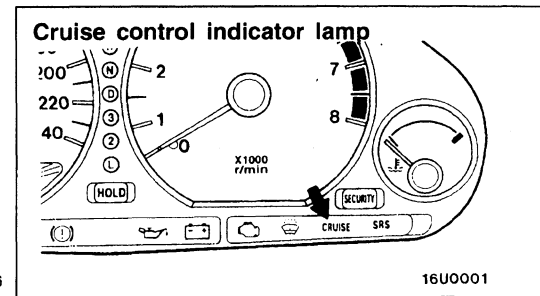
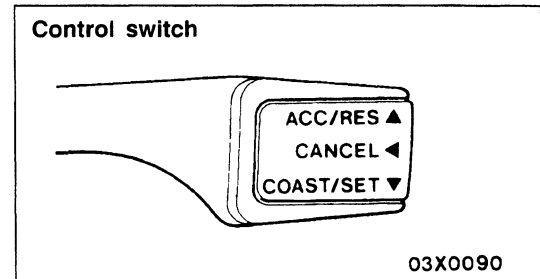
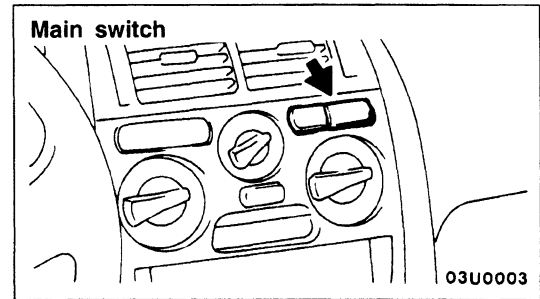

00003536

SERVICE SPECIFICATIONS

17200030040

Items	Standard value	
Accelerator cable play mm	M/T	0–1
	A/T	2–3
Throttle cable play mm		1–2
Auto-cruise control cable play mm		1–2

SPECIAL TOOL

17200060049

Tool	Number	Name	Use
	MB991502	MUT-II sub assembly	<ul style="list-style-type: none"> Reading diagnosis codes Auto-cruise control system check

TROUBLESHOOTING

17200070042

STANDARD FLOW OF DIAGNOSIS TROUBLESHOOTING

Refer to GROUP 00 – How to Use Troubleshooting/Inspection Service Points.

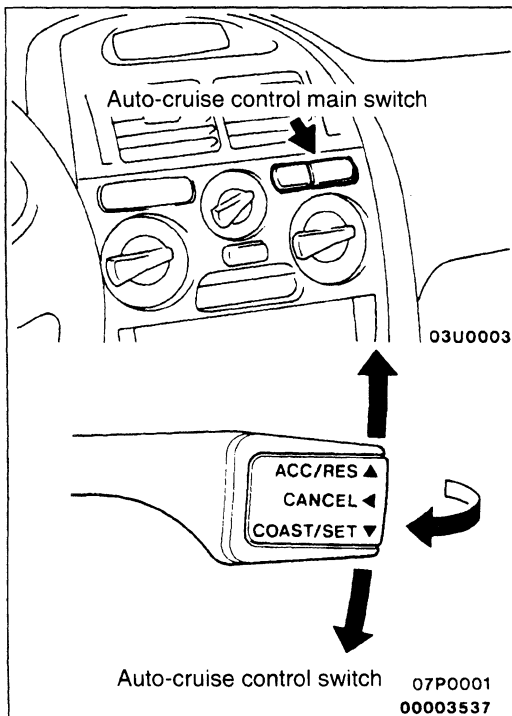

DIAGNOSIS FUNCTION

METHOD OF READING THE DIAGNOSIS CODES

1. Connect the MUT-II to the diagnosis connector (16-pin) under the instrument under cover. (Refer to GROUP 00 – How to Use Troubleshooting/Inspection Service Points.)
2. With the ignition switch in the ON position, turn the auto-cruise control main switch to ON and take a reading of the diagnosis codes.

METHOD OF ERASING THE DIAGNOSIS CODES

The diagnosis codes can be erased by disconnecting the (-) cable from the battery for 10 seconds or more and then re-connecting it, or by the following procedure.

1. Turn the ignition switch to ON.
2. After pushing the auto-cruise control switch in the direction of arrow (B) in the illustration, press the cruise control main switch to the ON position, and within 1 second after doing this, push the cruise control switch back in the direction of arrow (A).
3. After pushing the auto-cruise control switch once more in the direction of arrow (A) in the illustration and keeping it in this position, press the stop lamp switch to the ON position for 5 seconds or more.

INPUT SWITCH CODE CHECK METHOD

1. Connect the MUT-II to the diagnosis connector (16-pin) under the instrument under cover.
2. Turn the ignition switch to ON.
3. After pushing the auto-cruise control switch in the direction of arrow (B) in the illustration, press the cruise control main switch to the ON position, and within 1 second after doing this, push the cruise control switch back in the direction of arrow (A).
4. Operate each switch listed in the input check table and take a reading of the input switch codes with the MUT-II.

Input Check Table

Code No.	Input operation	Operation judgement
21	SET switch ON	Auto-cruise control-ECU judges that SET switch is ON
22	RESUME switch ON	Auto-cruise control-ECU judges that RESUME switch is ON
23	Stop lamp switch (ON when brake pedal depressed)	Auto-cruise control-ECU judges that stop lamp switch is ON
24	Vehicle speed signal	Auto-cruise control-ECU judges that vehicle speed is 40 km/h or higher
25		Auto-cruise control-ECU judges that vehicle speed is lower than 40 km/h
26	<ul style="list-style-type: none"> ● Clutch switch <M/T> (ON when clutch pedal depressed) ● Inhibitor switch <A/T> (ON when select lever in N range) 	Auto-cruise control-ECU judges that clutch switch <M/T> or inhibitor switch <A/T> is ON
27	CANCEL switch ON	Auto-cruise control-ECU judges that CANCEL switch is ON
28	Throttle position sensor (accelerator pedal position sensor*) signal	Auto-cruise control-ECU judges that throttle position sensor (accelerator pedal position sensor*) voltage is 1.5 V or more
29	Idle switch	Auto-cruise control-ECU judges that idle switch is OFF

NOTE

* : Vehicles with TCL

INSPECTION CHART FOR DIAGNOSIS CODES

Code No.	Diagnosis item	Reference page
11	Motor-driven vacuum pump drive system	17-8
12	Vehicle speed sensor system	17-8
14	Motor-driven vacuum pump power supply system	17-9
15	Auto-cruise control switch	17-9
16	Auto-cruise control-ECU	17-9
17	Throttle position sensor system <Vehicles without TCL> or accelerator pedal position sensor system <Vehicles with TCL>	17-10

17-8 ENGINE AND EMISSION CONTROL – Auto-cruise Control System

INSPECTION PROCEDURE FOR DIAGNOSIS CODES

Code No. 11 Motor-driven vacuum pump drive system	Probable cause
This diagnosis code is output if the release valve, control valve or motor drive signals from the electric vacuum pump are not input to the auto-cruise control-ECU.	<ul style="list-style-type: none"> ● Malfunction of the motor-driven vacuum pump ● Malfunction of the connector ● Malfunction of the harness ● Malfunction of the auto-cruise control-ECU

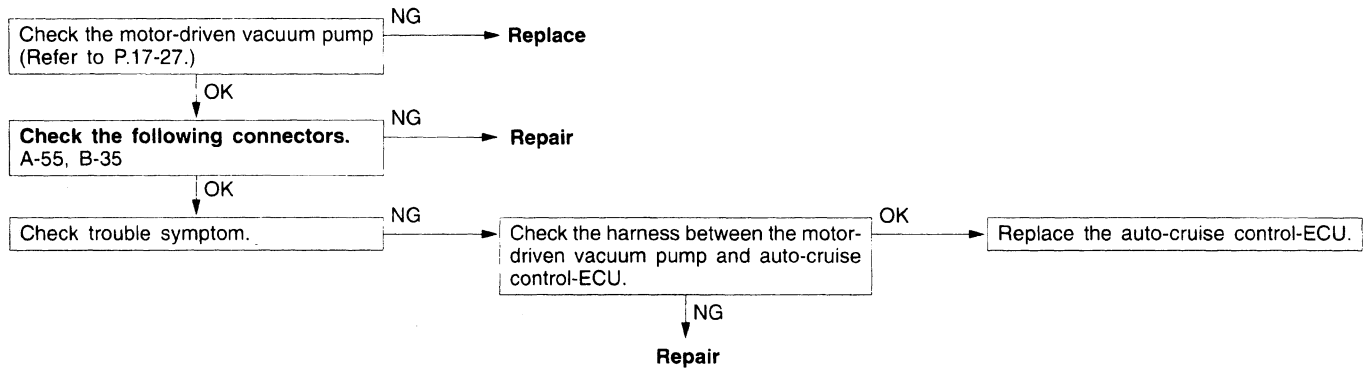

Code No. 12 Vehicle speed signal system	Probable cause
This diagnosis code is output if the vehicle speed signals from the vehicle speed sensor are not input to the auto-cruise control-ECU when the vehicle speed is 40 km/h or more.	<ul style="list-style-type: none"> ● Malfunction of the vehicle speed sensor ● Malfunction of the connector ● Malfunction of the harness ● Malfunction of the auto-cruise control-ECU

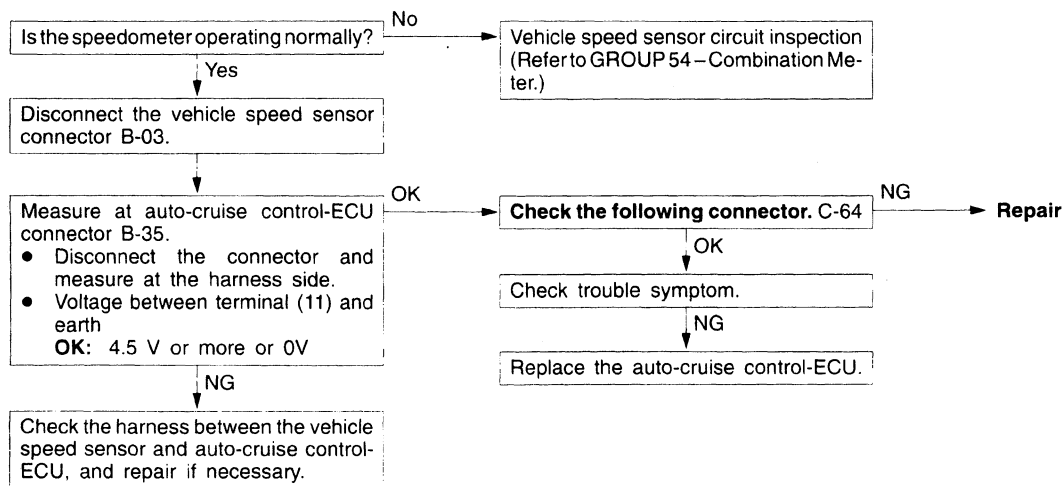

Code No. 14 Motor-driven vacuum pump power supply system	Probable cause
<p>This diagnosis code is output when none of the drive signals from the release valve, control valve and motor of the motor-driven vacuum pump are input to the auto-cruise control-ECU.</p>	<ul style="list-style-type: none"> Malfunction of the stop lamp switch Malfunction of the connector Malfunction of the harness Malfunction of the auto-cruise control-ECU Malfunction of the motor-driven vacuum pump

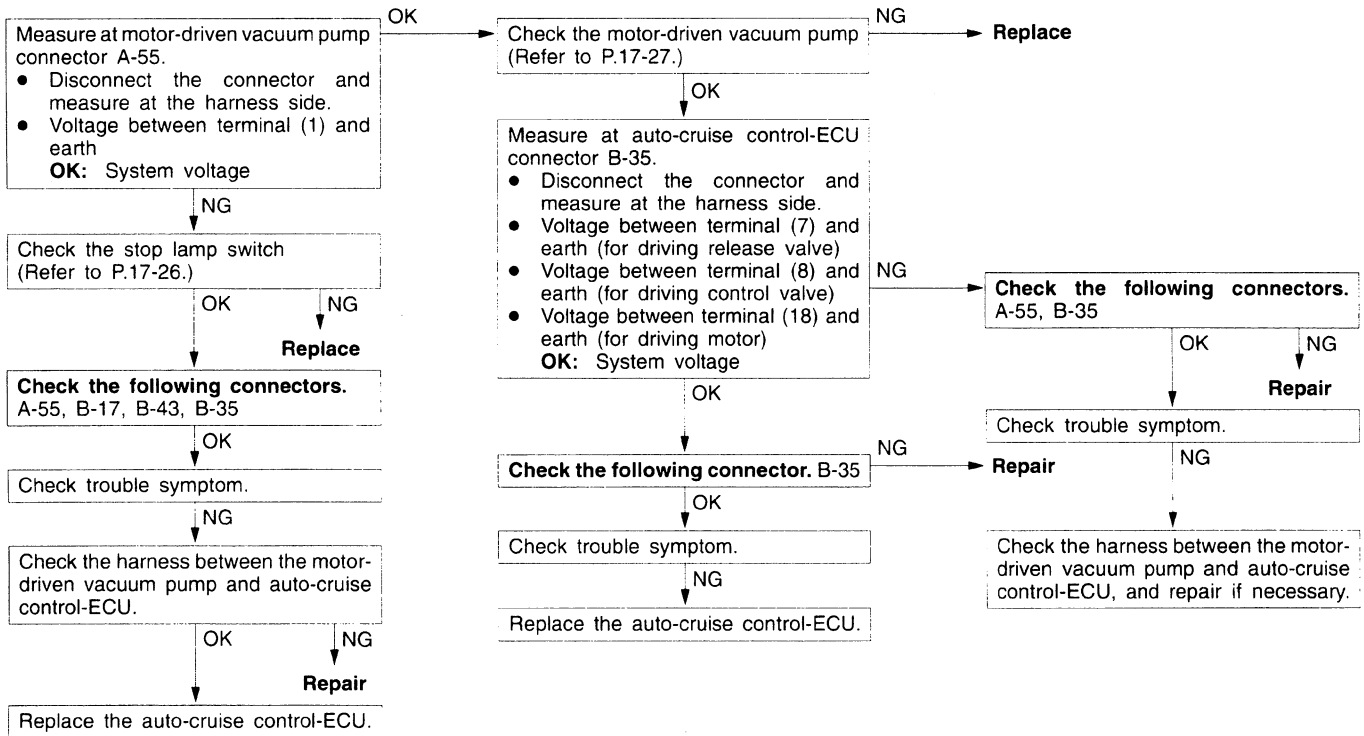

Code No. 15 Auto-cruise control switch	Probable cause
<p>This diagnosis code is output if the cruise control RESUME switch, SET switch or CANCEL switch remains ON.</p>	<ul style="list-style-type: none"> Malfunction of the auto-cruise control switch

Replace the auto-cruise control switch.

Code No. 16 Auto-cruise control-ECU	Probable cause
<p>This diagnosis code is output if there is an abnormality in the CANCEL hold circuit or the microprocessor monitor circuit in the auto-cruise control-ECU.</p>	<ul style="list-style-type: none"> Malfunction of the auto-cruise control-ECU

Replace the auto-cruise control-ECU.

17-10 ENGINE AND EMISSION CONTROL – Auto-cruise Control System

Code No. 17 Throttle position sensor system <Vehicles without TCL> or accelerator pedal position sensor system <Vehicles with TCL>	Probable cause
<p>This diagnosis code is output if a voltage of 1.5 V or more when the idle switch is ON or 0.2 V or less when the idle switch is OFF is output for a continuous period of 4 seconds or more.</p>	<ul style="list-style-type: none"> Malfunction of the throttle position sensor <Vehicles without TCL> Malfunction of the accelerator pedal position sensor <Vehicles with TCL> Malfunction of the connector Malfunction of the harness Malfunction of the auto-cruise control-ECU

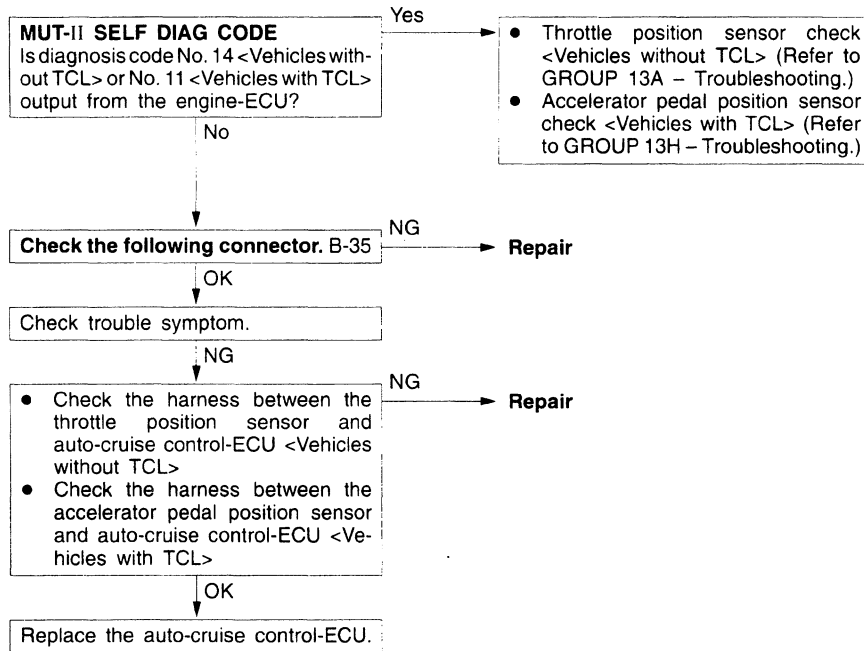

INSPECTION CHART FOR TROUBLE SYMPTOMS

Trouble symptom	Inspection procedure No.	Reference page
Communication with MUT-II is not possible.	Communication with all systems is not possible.	1 17-11
	Communication with auto-cruise control-ECU only is not possible.	2 17-12
Input switch inspection using the MUT-II is not possible. (However, diagnosis inspection is possible.)	3	17-13

Trouble symptom	Inspection procedure No.	Reference page
Auto-cruise control is not cancelled.	Even if brake pedal is depressed	4
	Even if clutch pedal is depressed <M/T>	5
	Even if select lever is set to N range <A/T>	6
	Even if CANCEL switch is set to ON	7
The diagnosis result displayed on the MUT-II is normal even though auto-cruise control cannot be set.	8	17-16
Auto-cruise control cannot be set.	9	17-17
Hunting (repeated acceleration and deceleration) occurs at the set vehicle speed.	10	17-18
Even though auto-cruise control main switch is ON, switch indicator lamp does not illuminate. (However, auto-cruise control is normal.)	11	17-18
Auto-cruise control main switch illumination lamp does not illuminate.	12	17-19
Auto-cruise control indicator lamp inside combination meter does not illuminate. (However, auto-cruise control is normal.)	13	17-19

INSPECTION PROCEDURE FOR TROUBLE SYMPTOMS

Inspection Procedure 1

Communication with MUT-II is not possible. (Communication with all system is not possible.)	Probable cause
The reason is probably a defect in the power supply system (including earth) for the diagnosis line.	<ul style="list-style-type: none"> ● Malfunction of the connector ● Malfunction of the harness

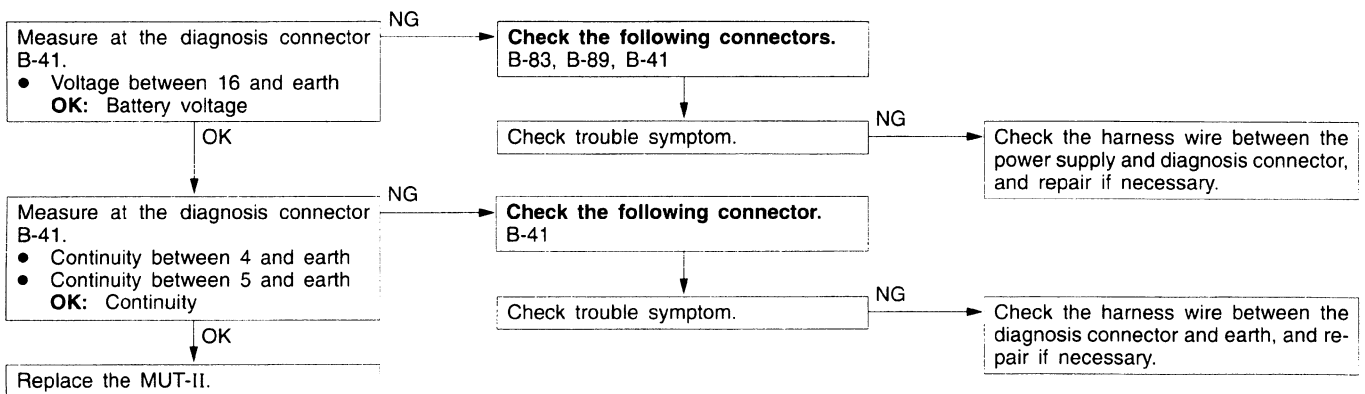

17-12 ENGINE AND EMISSION CONTROL – Auto-cruise Control System

Inspection Procedure 2

Communication with MUT-II is not possible. (Communication with auto-cruise control-ECU only is not possible.)	Probable cause
The cause is probably a malfunction of auto-cruise control main switch circuit or a malfunction of auto-cruise control-ECU earth circuit.	<ul style="list-style-type: none"> ● Malfunction of the auto-cruise control main switch ● Malfunction of the connector ● Malfunction of the harness ● Malfunction of the auto-cruise control-ECU

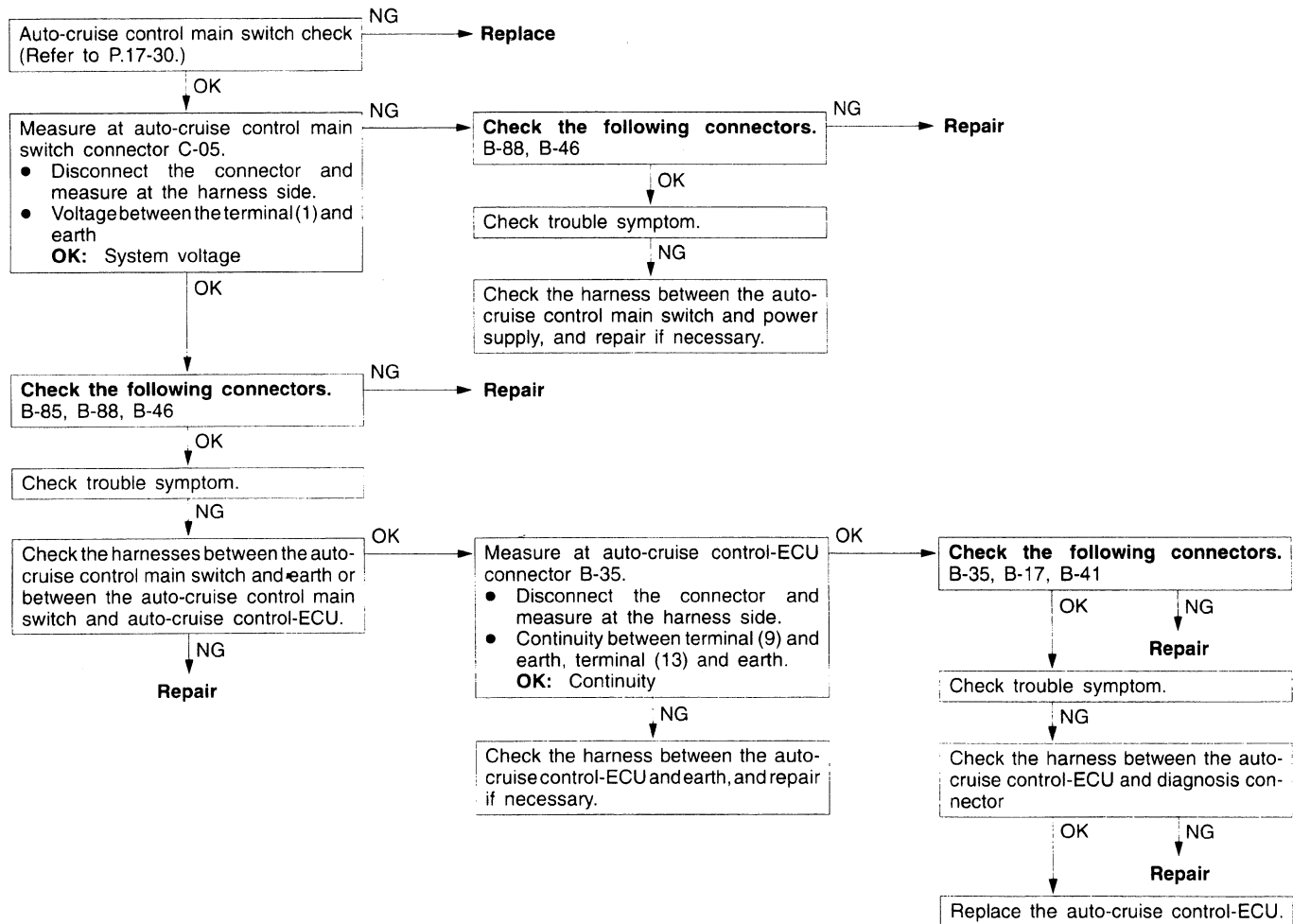

Inspection Procedure 3

Input switch inspection using the MUT-II is not possible. (However, diagnosis inspection is possible.)	Probable cause
The cause is probably a malfunction of auto-cruise control switch circuit system.	<ul style="list-style-type: none"> Malfunction of the auto-cruise control switch Malfunction of the slip ring <Vehicles without SRS> Malfunction of the clock spring <Vehicles with SRS> Malfunction of the connector Malfunction of the harness

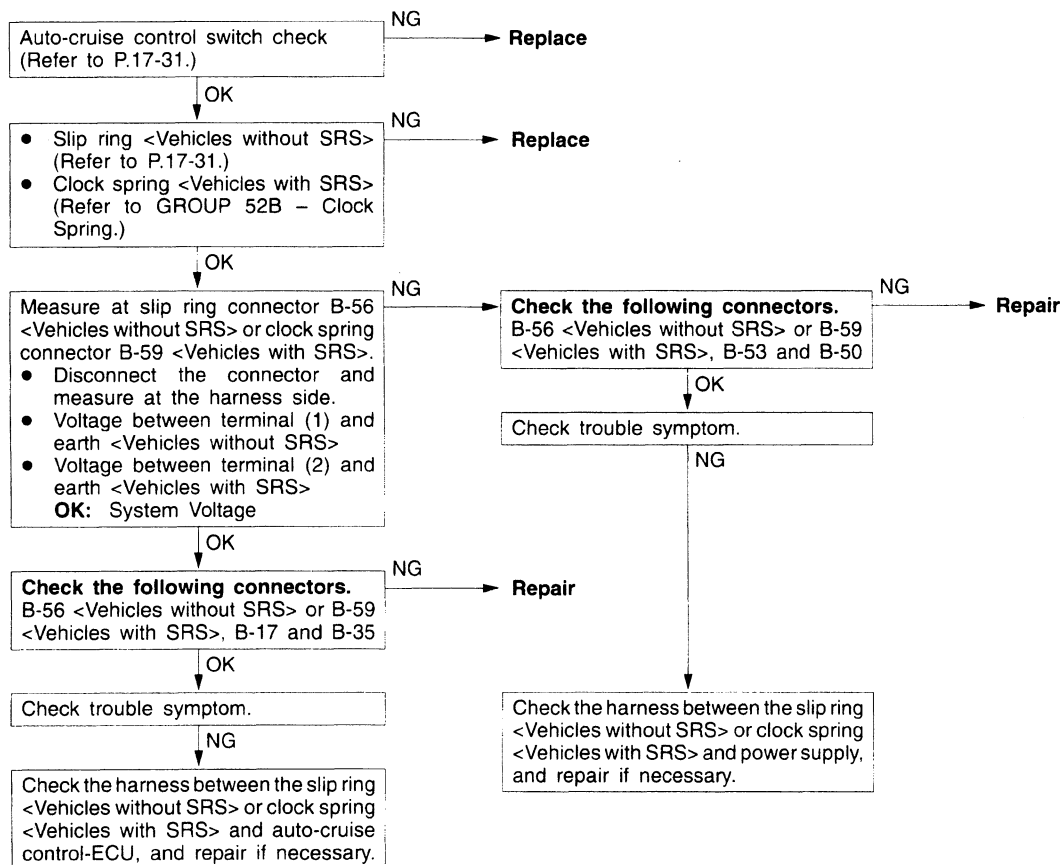

17-14 ENGINE AND EMISSION CONTROL – Auto-cruise Control System

Inspection Procedure 4

Even if brake pedal is depressed, auto-cruise control is not cancelled.	Probable cause
The cause is probably a malfunction of stop lamp switch or a malfunction of stop lamp circuit.	<ul style="list-style-type: none"> ● Malfunction of the stop lamp switch ● Malfunction of the connector ● Malfunction of the harness ● Malfunction of the auto-cruise control-ECU

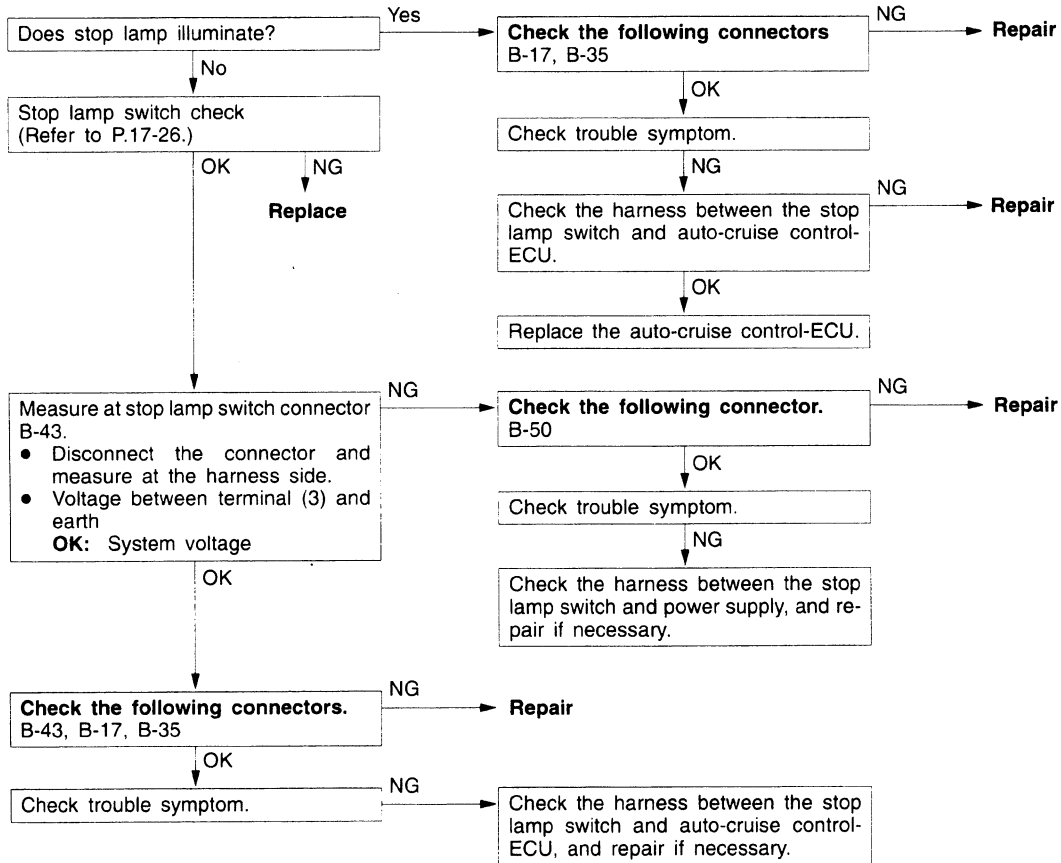

Inspection Procedure 5

Even if clutch pedal is depressed, auto-cruise control is not cancelled. <M/T>	Probable cause
The cause is probably a malfunction of clutch switch or clutch circuit.	<ul style="list-style-type: none"> ● Malfunction of the clutch switch ● Malfunction of the connector ● Malfunction of the harness ● Malfunction of the auto-cruise control-ECU

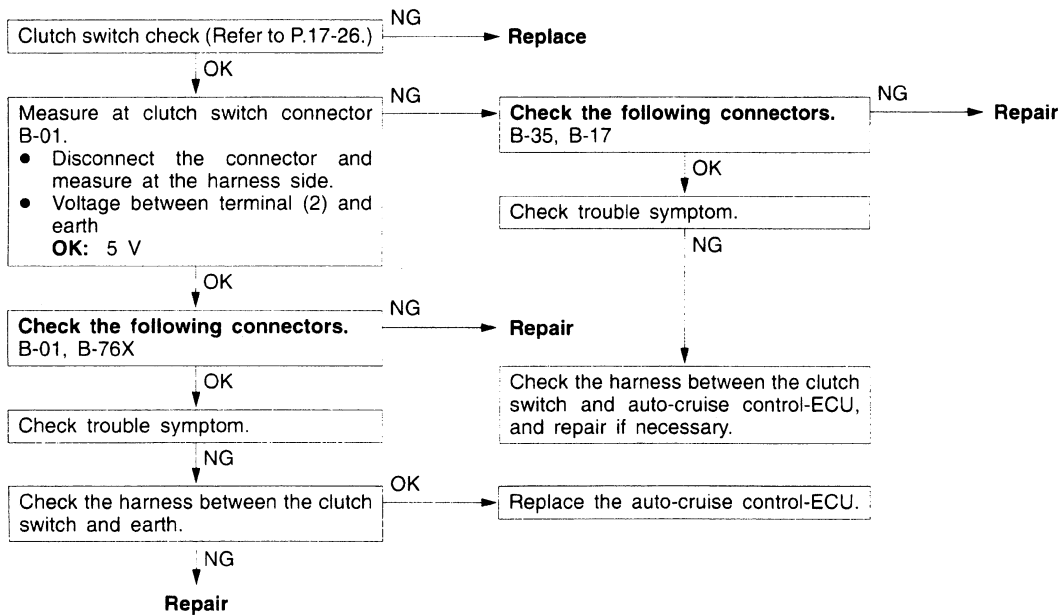

Inspection Procedure 6

Even if select lever is set to N range, auto-cruise control is not cancelled. <A/T>	Probable cause
The cause is probably an open-circuit in the output signal circuit in N range.	<ul style="list-style-type: none"> ● Malfunction of the connector ● Malfunction of the harness ● Malfunction of the auto-cruise control-ECU

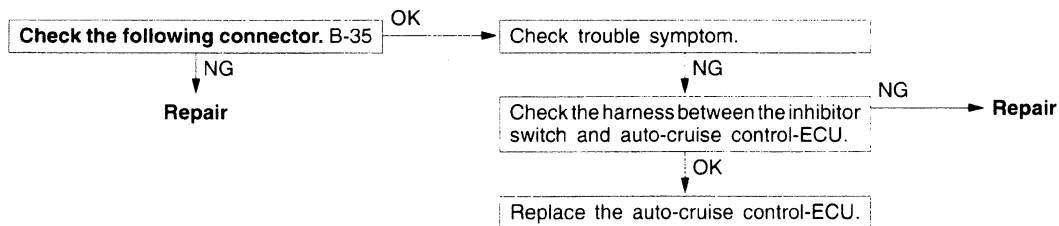

17-16 ENGINE AND EMISSION CONTROL – Auto-cruise Control System

Inspection Procedure 7

Even if auto-cruise control CANCEL switch is set to ON, auto-cruise control is not cancelled.	Probable cause
The cause is probably an open-circuit in the circuit inside the CANCEL switch.	<ul style="list-style-type: none"> • Malfunction of the auto-cruise control-ECU

Replace the auto-cruise control switch.

Inspection Procedure 8

The diagnosis result displayed on the MUT-II is normal even though auto-cruise control cannot be set.	Probable cause
Because of an open-circuit in the battery backup circuit system, the fail-safe function prevents diagnosis codes from being memorised and displayed even though auto-cruise control is cancelled.	<ul style="list-style-type: none"> • Malfunction of the connector • Malfunction of the harness • Malfunction of the auto-cruise control-ECU

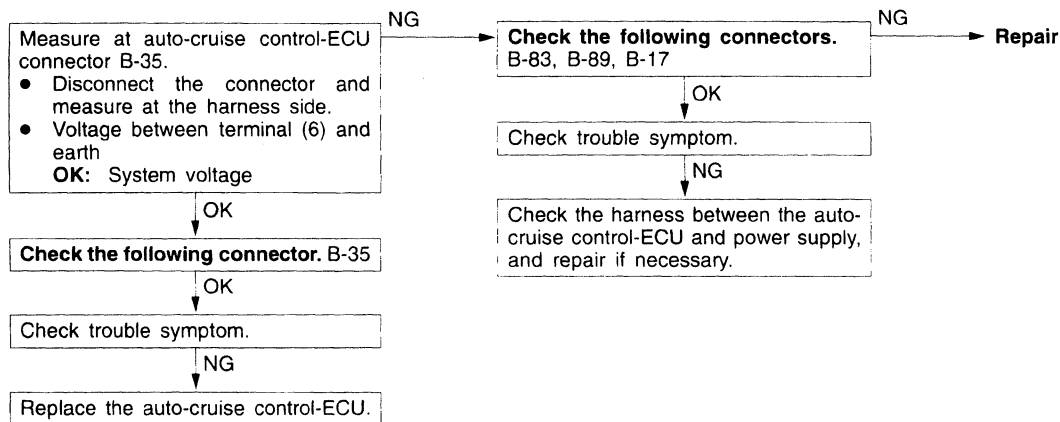

Inspection Procedure 9

Auto-cruise control cannot be set.	Probable cause
<p>The cause is probably that the fail-safe function is cancelling auto-cruise control. In this case, the MUT-II can be used to check the trouble symptoms in each system by inspecting the diagnosis codes. The MUT-II can also be used to check if the circuits of each input switch are normal or not by inspecting the input switch codes.</p>	<ul style="list-style-type: none"> Malfunction of the auto-cruise control main switch Malfunction of the auto-cruise control switch Malfunction of the slip ring <Vehicles without SRS> Malfunction of the clock spring <Vehicles with SRS> Malfunction of the harnesses or connectors Malfunction of the clutch switch <M/T> Malfunction of the auto-cruise control-ECU

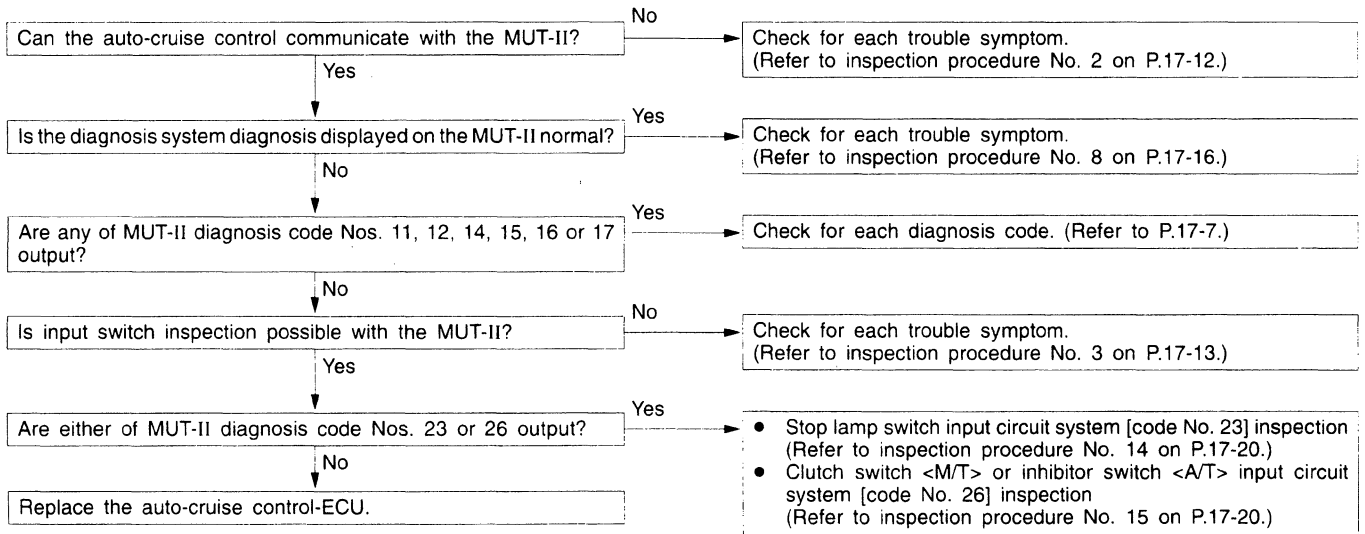

17-18 ENGINE AND EMISSION CONTROL – Auto-cruise Control System

Inspection Procedure 10

Hunting (repeated acceleration and deceleration) occurs at the set vehicle speed.	Probable cause
The cause is probably a malfunction of vehicle speed sensor or incorrect vacuum in the motor-driven vacuum pump or actuator.	<ul style="list-style-type: none"> ● Malfunction of the vehicle speed sensor ● Malfunction of the motor-driven vacuum pump ● Malfunction of the actuator ● Malfunction of the auto-cruise control-ECU

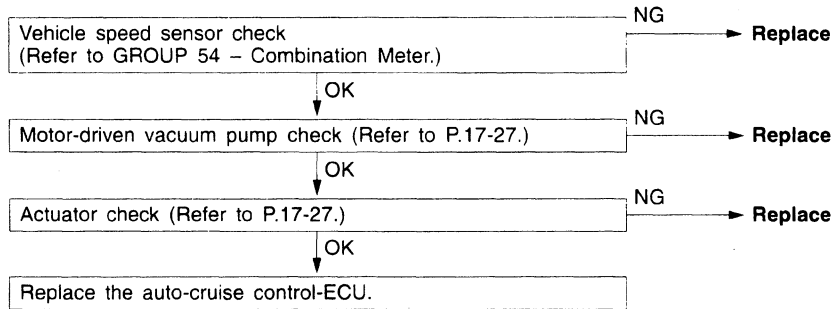

Inspection Procedure 11

Even though auto-cruise control main switch is ON, switch indicator lamp does not illuminate. (However, auto-cruise control is normal.)	Probable cause
Blown bulb in auto-cruise control main switch	<ul style="list-style-type: none"> ● Malfunction of the auto-cruise control main switch

Replace the auto-cruise control main switch.

Inspection Procedure 12

Auto-cruise control main switch illumination lamp does not illuminate.	Probable cause
The cause is probably a malfunction of auto-cruise control main switch or a malfunction of harness or connector.	<ul style="list-style-type: none"> Malfunction of the auto-cruise control main switch Malfunction of the connector Malfunction of the harness

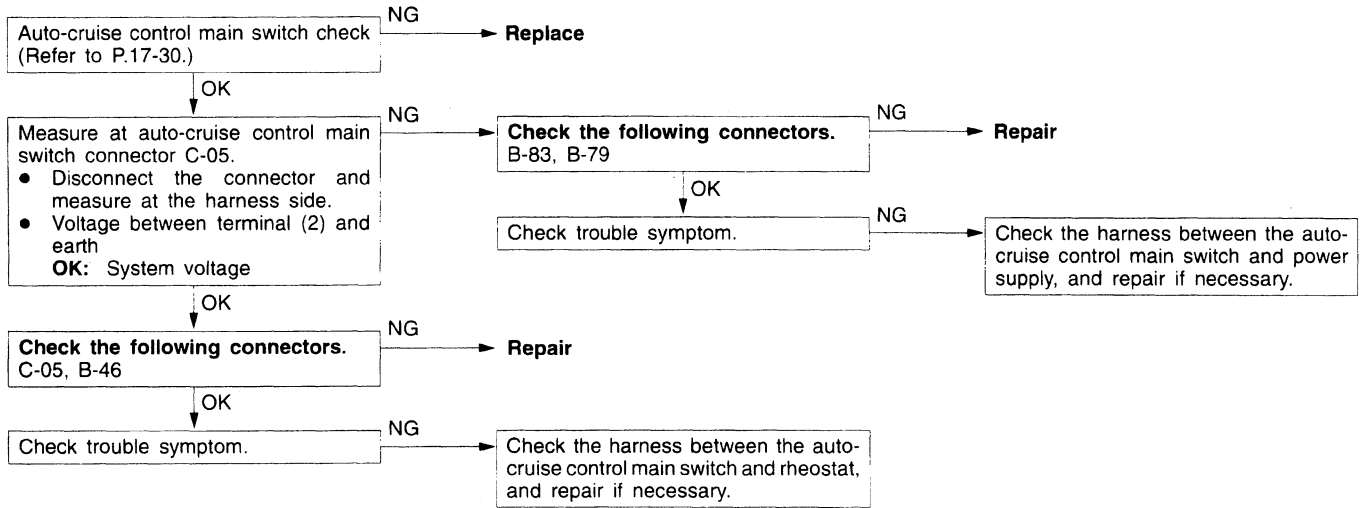

Inspection Procedure 13

Auto-cruise control indicator lamp inside combination meter does not illuminate. (However, auto-cruise control is normal.)	Probable cause
The cause is probably a malfunction of valve or a malfunction of connector or harness.	<ul style="list-style-type: none"> Malfunction of the valve Malfunction of the harness Malfunction of the connector Malfunction of the auto-cruise control-ECU

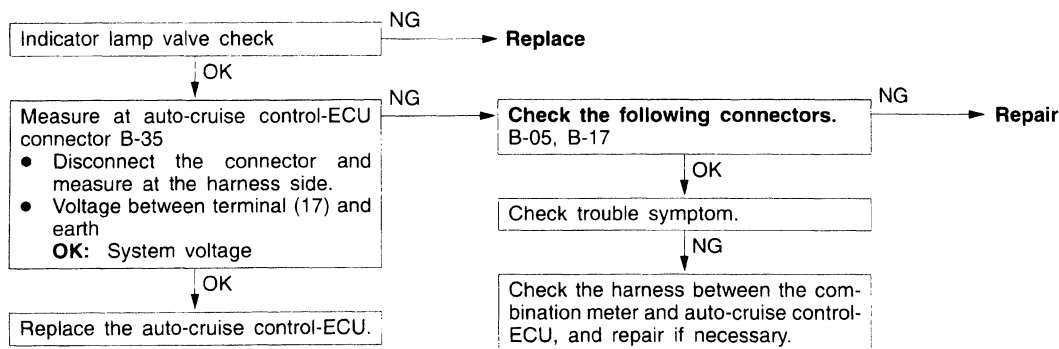

17-20 ENGINE AND EMISSION CONTROL – Auto-cruise Control System

Inspection Procedure 14

Stop lamp switch input circuit system inspection (Code No. 23)

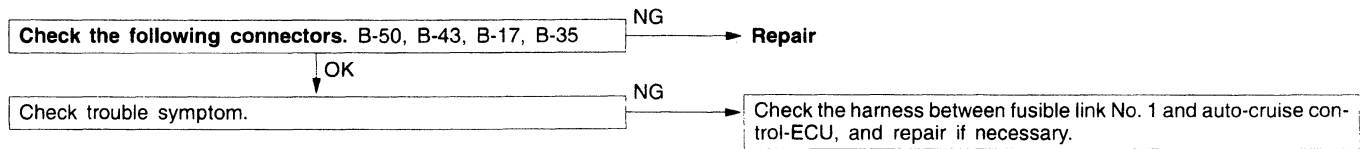

Inspection Procedure 15

Clutch switch <M/T> or inhibitor switch <A/T> input circuit system inspection (Code No. 26)

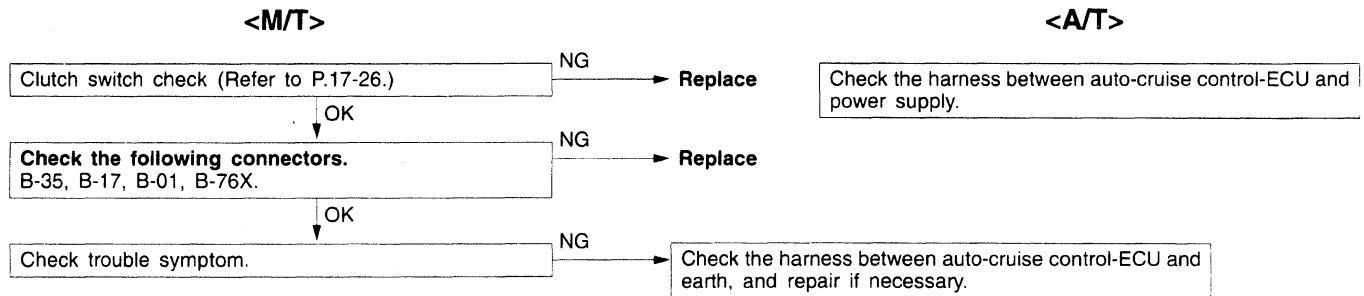

CHECK AT THE ECU TERMINALS

1	2	3	4		5	6	7	8
9	10	11	12	13	14	15	16	17

03U0031

Terminal No.	Check item	Check conditions	Normal condition	
1	Throttle position sensor input	When accelerator pedal is fully depressed	4.5–5.5V	
		When accelerator pedal is released	0.3–1.0V	
2	Idle switch output	When accelerator pedal is depressed	When idle switch is OFF 4.5–5.5V	
		When accelerator pedal is not depressed	When idle switch is ON 0V	
3	ACC power supply	When ignition switch is in ACC position	System voltage	
4	Stop lamp switch input	When brake pedal is depressed	When stop lamp switch is ON System voltage	
		When brake pedal is not depressed	When stop lamp switch is OFF 0V	
5	Diagnosis control input	When ignition switch is ON	4V or more	
6	ECU backup power supply	At any time	System voltage	
7	Motor-driven vacuum pump release valve and control valve input	When decelerating with the SET switch while driving at constant speed	Release valve closed	0V
8			Control valve open	System voltage
7		When cancelling constant speed driving with the CANCEL switch	Release valve open	System voltage
8			Control valve open	System voltage
9	Earth	At any time	Continuity	
10	A/T control output	No OD-OFF request	System voltage	
		OD-OFF request	0V	

17-22 ENGINE AND EMISSION CONTROL – Auto-cruise Control System

Terminal No.	Check item	Check conditions		Normal condition
11	Vehicle speed sensor input	When vehicle is moved forwards and backwards, sensor turns ON and OFF repeatedly	When sensor is ON	0V
			When sensor is OFF	4.5V or more
12	Auto-cruise control switch input	When input switch has not been operated	When all switches are OFF	0V
		When input switch is pushed down	When SET switch is ON	3V
		When input switch is pushed up	When RESUME switch is ON	6V
		When input switch is pulled forward	When CANCEL switch is ON	System voltage
13	Earth	At any time		Continuity
14	Clutch switch input <M/T>	When pedal is not depressed	When clutch switch is OFF	5V
		When pedal is depressed	When clutch switch is ON	0V
	Inhibitor switch input <A/T>	When select lever is in a position other than N range	When inhibitor switch is OFF	System voltage
		When select lever is in N range	When inhibitor switch is ON	0V
15	Pump power supply	Ignition switch : ON Main switch : ON Stop lamp switch : OFF		System voltage
16	ECU power supply	Ignition switch : ON Main switch : ON		System voltage
17	Indicator lamp input (inside combination meter)	When driving at constant speed	When indicator lamp is illuminated	0V
		When constant-speed driving is cancelled	When indicator lamp is switched off	System voltage
18	Motor-driven vacuum pump motor input	When driving at constant speed using the SET switch	Motor stopped/running	System voltage/0V
		When accelerating with the RESUME switch while driving at constant speed	Motor stopped/running	System voltage/0V
		When decelerating with the SET switch while driving at constant speed	Motor stopped	System voltage
		When cancelling constant speed driving with the CANCEL switch	Motor stopped	System voltage

ON-VEHICLE SERVICE

17200090048

AUTO-CRUISE CONTROL CABLE CHECK AND ADJUSTMENT

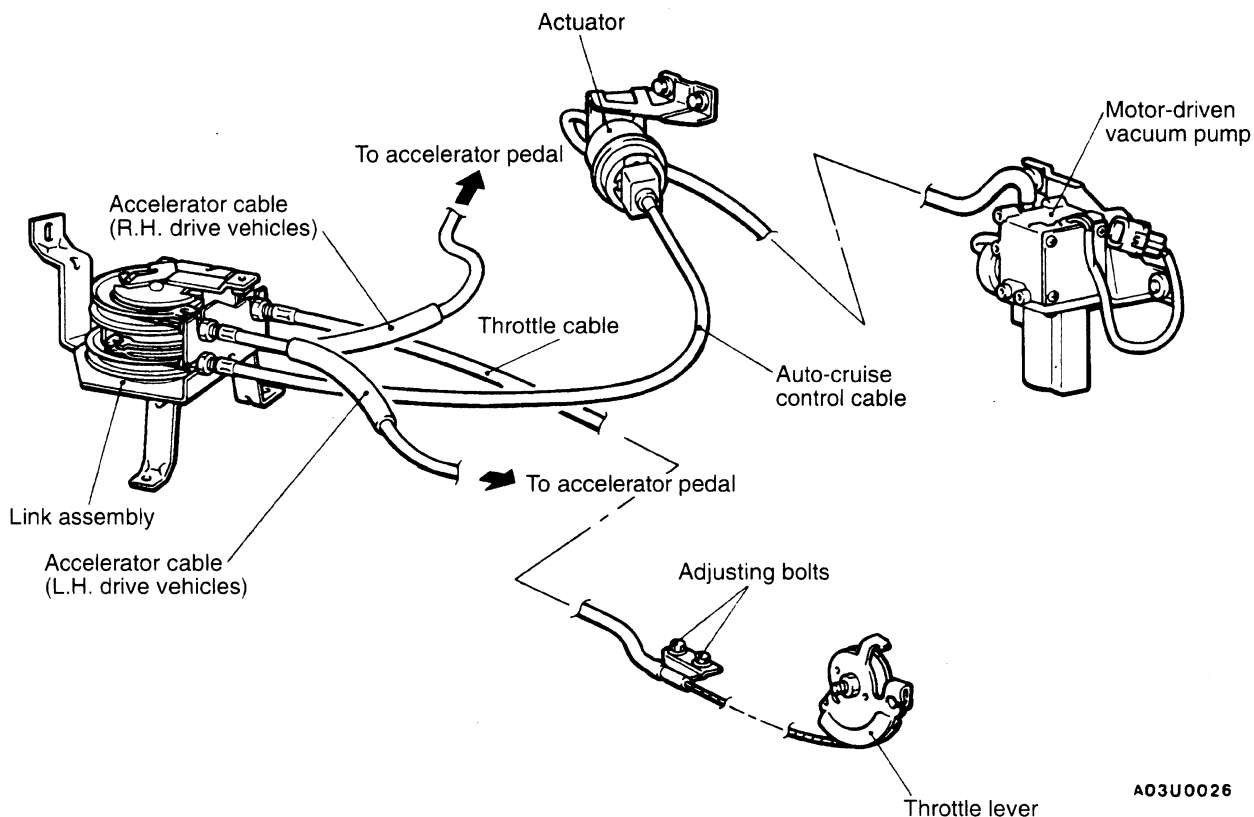

A03U0026

1. Remove the link protector. (Refer to P.17-28.)
2. Check the slack in each of the inner cables in the accelerator cable, auto-cruise control cable and throttle cable.

If the slack in an inner cable is excessive, or if there is no play, loosen the adjusting bolts and the nuts in the throttle lever and each link, to release the throttle lever and each link. (The bolts and nuts should not be removed.)

17-24 ENGINE AND EMISSION CONTROL – Auto-cruise Control System

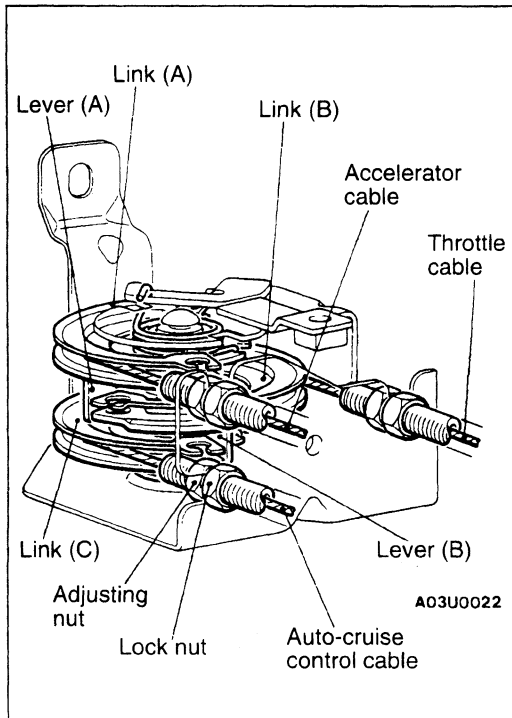

ACCELERATOR CABLE

1. While holding link (A) at the position where it is touching the stopper, turn the adjusting nut to adjust the accelerator cable play to the standard value.

Amount to unscrew the adjusting nut:

<M/T> Approx. half a turn (inner cable play 0–1 mm)

<A/T> Approx. 2 turns (inner cable play 2–3 mm)

2. Fix the accelerator cable with the lock nut.

THROTTLE CABLE

1. While holding link (B) at the position where it is touching the lever of link (A), turn the adjusting nut to adjust the throttle cable play to the standard value.

Amount to unscrew the adjusting nut:

Approx. 1 turn (inner cable play 1–2 mm)

2. Fix the throttle cable with the lock nut.
3. Tighten the throttle lever-side adjusting bolt to the specified torque.

AUTO-CRUISE CONTROL CABLE

1. While holding link (C) at the position where it is touching the lever of link (B), turn the adjusting nut to adjust the auto-cruise control cable play to the standard value.

Amount to unscrew the adjusting nut:

Approx. 1 turn (inner cable play 1–2 mm)

2. Fix the auto-cruise control cable with the lock nut.

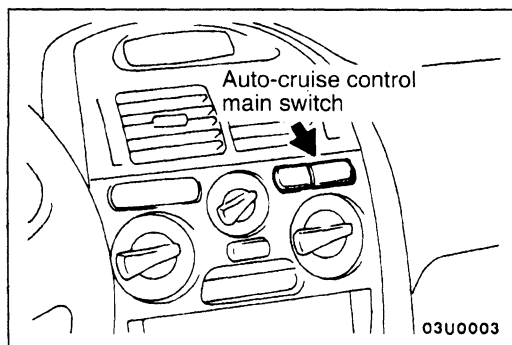

AUTO-CRUISE CONTROL MAIN SWITCH CHECK

17200110041

1. Turn the ignition key to ON.
2. Check to be sure that the indicator lamp within the switch illuminates when the main switch is switched ON.

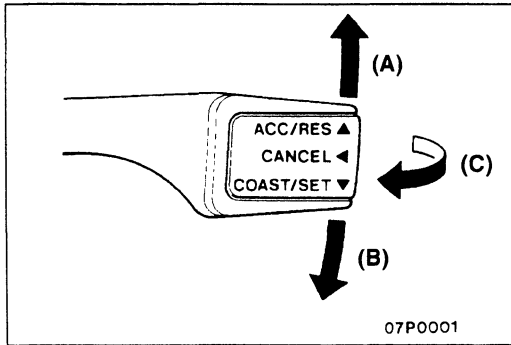

AUTO-CRUISE CONTROL SWITCH CHECK

17200120044

AUTO-CRUISE CONTROL SETTING

1. Switch ON the main switch.
2. Drive at the desired speed within the range of approximately 40–200 km/h.
3. Push the auto-cruise control switch in the direction of arrow (B).
4. Check to be sure that when the switch is released the speed is the desired constant speed.

NOTE

If the vehicle's speed decreases to approximately 15 km/h below the set speed because of climbing a hill for example, the auto-cruise control will be cancelled.

SPEED-INCREASE SETTING

1. Set to the desired speed.
2. Push the auto-cruise control switch in the direction of arrow (A).
3. Check to be sure that acceleration continues while the switch is held, and that when it is released the constant speed at the time when it was released becomes the driving speed.

NOTE

Acceleration can be continued even if the vehicle speed has passed the high-speed limit (approx. 200 km/h). But the speed when the auto-cruise control switch is released will be recorded as the high-speed limit.

SPEED-REDUCTION SETTING

1. Set to the desired speed.
2. Push the auto-cruise control switch in the direction of arrow (B).
3. Check to be sure that deceleration continues while the switch is pressed, and that when it is released the constant speed at the time when it was released becomes the driving speed.

NOTE

When the vehicle speed reaches the low limit (approximately 40 km/h) during deceleration, the auto-cruise control will be cancelled.

RETURN TO THE SET SPEED BEFORE CANCELLATION AND AUTO-CRUISE CONTROL CANCELLATION

1. Set the auto-cruise speed control.
2. When any of the following operations are performed while at constant speed during auto-cruise control, check if normal driving is resumed and deceleration occurs.
 - a. The auto-cruise control switch is pushed in the direction of arrow (C).
 - b. The brake pedal is depressed.
 - c. The clutch pedal is depressed. (M/T)
 - d. The selector lever is moved to the "N" range. (A/T)
3. At a vehicle speed of 40 km/h or higher, check if when the RESUME switch is switched ON, vehicle speed returns to the speed before auto-cruise control driving was cancelled, and constant speed driving occurs.
4. When the main switch is turned to OFF while driving at constant speed, check if normal driving is resumed and deceleration occurs.

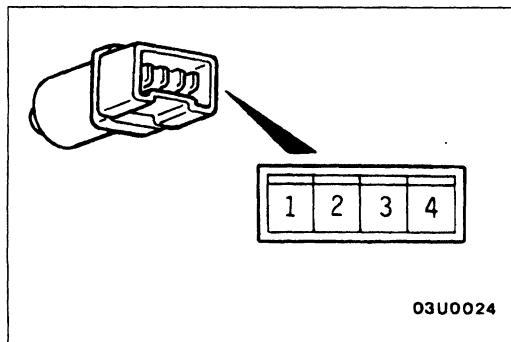

AUTO-CRUISE CONTROL COMPONENT CHECK

17200170049

STOP LAMP SWITCH

1. Disconnect the connector.
2. Check for continuity between the terminals of the switch.

Measurement conditions	Terminal No.			
	1	2	3	4
When brake pedal depressed. (for stop lamp circuit)		○—○		
When brake pedal not depressed. (for auto-cruise control circuit)	○—○			

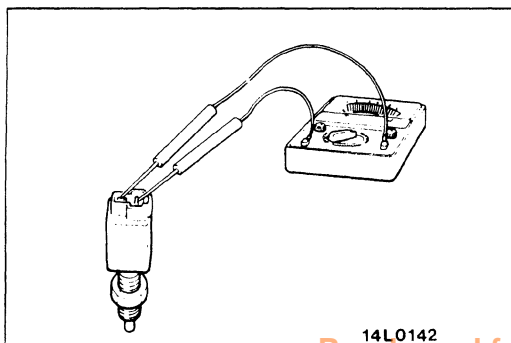

CLUTCH SWITCH

1. Remove the clutch switch connector.
2. Check if there is continuity between the clutch terminals while the clutch pedal is depressed, and if there is no continuity when the clutch pedal is released.

INHIBITOR SWITCH (“N” POSITION)

Refer to GROUP 23 – On-vehicle Service.

THROTTLE POSITION SENSOR

Refer to GROUP 13A – On-vehicle Service.

ACCELERATOR PEDAL POSITION SENSOR

<Vehicle with TCL>

Refer to GROUP 13 H – On-vehicle Service.

MOTOR-DRIVEN VACUUM PUMP

1. Disconnect the vacuum hose from the motor-driven vacuum pump and connect a vacuum gauge to the vacuum pump.
2. Disconnect the electric vacuum pump connector.
3. Check that the reading on the vacuum gauge matches the values in the table below when the battery is connected to each connector terminal.

Terminal No.				Valve condition	Vacuum gauge kPa
1	2	3	4		
+	-	-	-	Release valve closed Control valve closed	53 or more
+	-	-	-	Release valve open	20 or less
+	-	-	-	Control valve open	

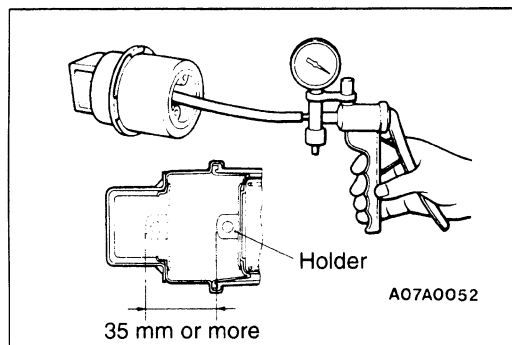
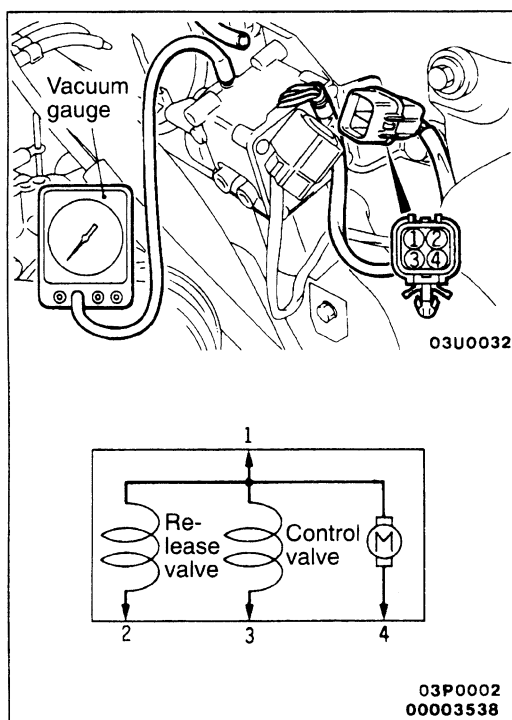

ACTUATOR

1. Remove the actuator.
2. Apply negative pressure to the actuator with the vacuum pump and check that the holder moves more than 35 mm. In addition, check that there is no change in the position of the holder when negative pressure is maintained in that condition.
3. First install the actuator and then inspect and adjust the auto-cruise control cable (Refer to P.17-24.)

**AUTO-CRUISE CONTROL
REMOVAL AND INSTALLATION**

17200140040

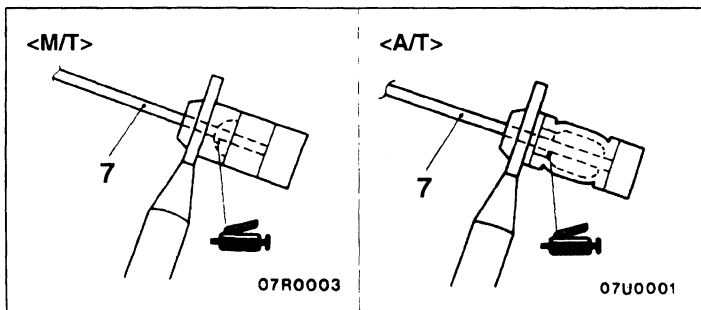
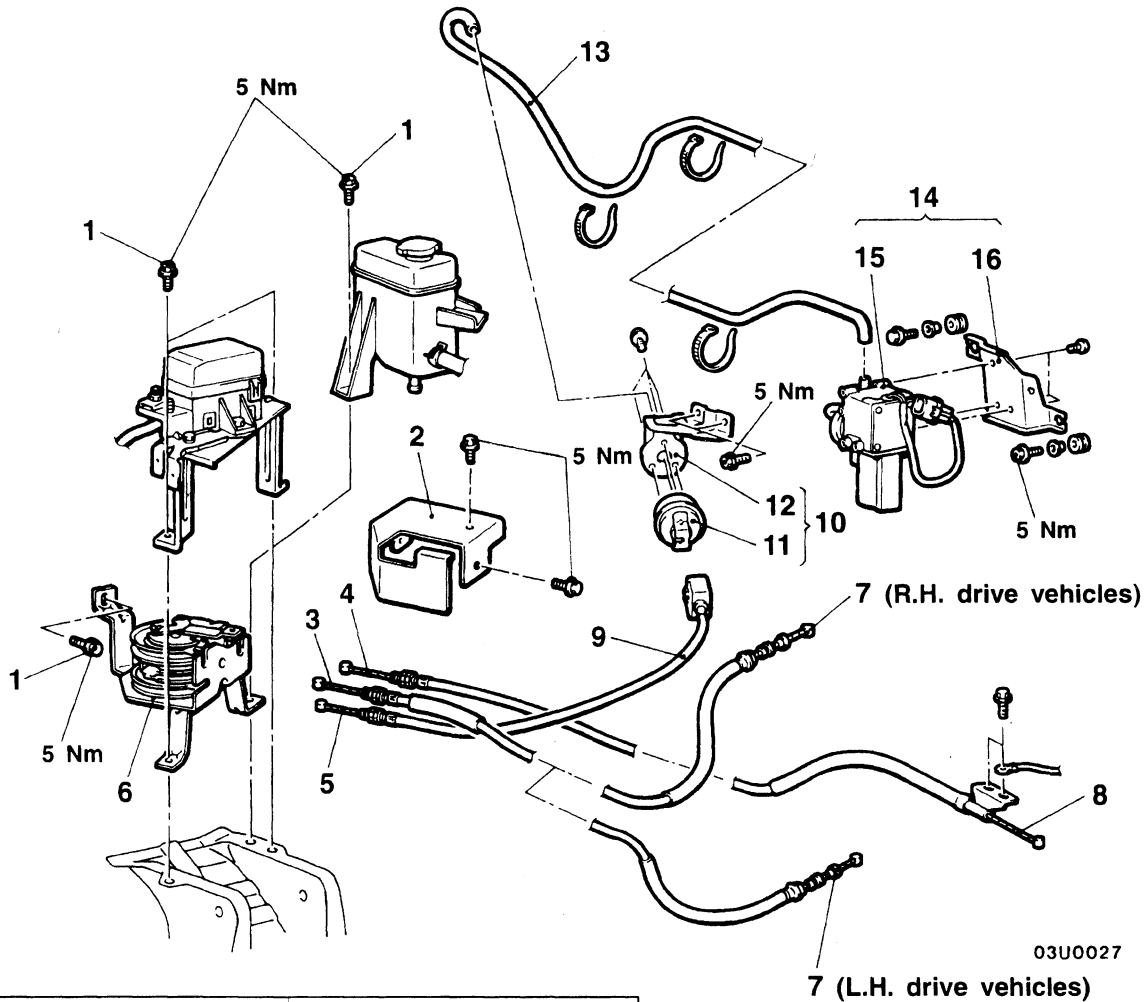

03U0027

7 (L.H. drive vehicles)

00003539

Link assembly removal steps

1. Bolts
2. Link protector
3. Accelerator cable connection
4. Throttle cable connection
5. Auto-cruise control cable connection
6. Link assembly
7. Accelerator cable connection
8. Throttle cable connection

Actuator removal steps

9. Auto-cruise control cable connection
10. Actuator and bracket assembly
11. Actuator
12. Actuator bracket
13. Vacuum hose
14. Auto-cruise vacuum pump and bracket assembly
15. Motor-driven vacuum pump assembly
16. Pump bracket

CAUTION: SRS
 Before removal of air bag module, refer to GROUP 52B – SRS Service Precautions and Air Bag Module and Clock Spring.

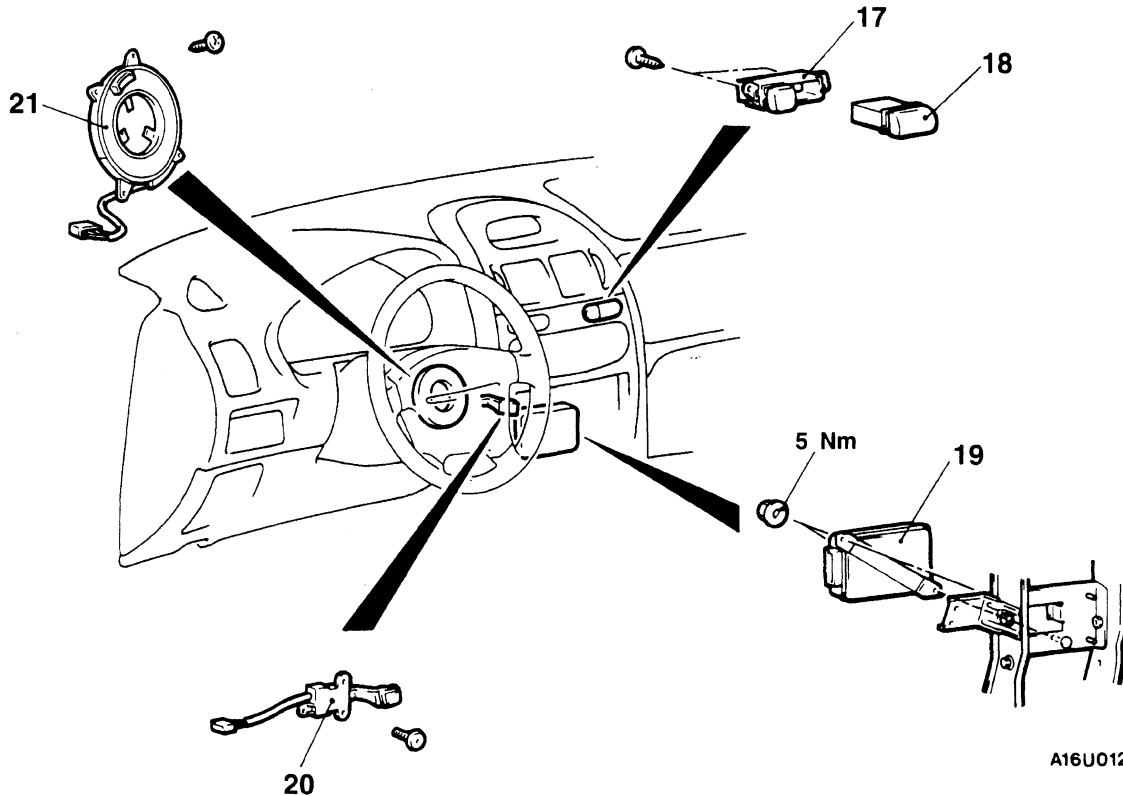

A16U0129

Main switch removal steps

- Center console panel (Refer to GROUP 52A – Floor Console.)
- Center pillar lower trim (Refer to GROUP 52A.)
- 17. Switch case
- 18. Main switch

Control unit removal

- Console side cover, radio and tape player (Refer to GROUP 52A.)
- 19. Auto-cruise control ECU

Control switch removal steps

- Air bag module <Vehicles with SRS> (Refer to GROUP 52B.)
- Horn switch (Refer to GROUP 37A – Steering Wheel and Shaft.)
- 20. Control switch
 - Steering wheel <Vehicles without SRS> (Refer to GROUP 37A.)
- 21. Slip ring <Vehicles without SRS>

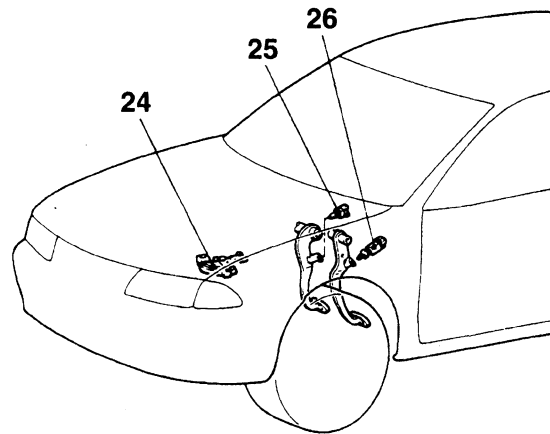
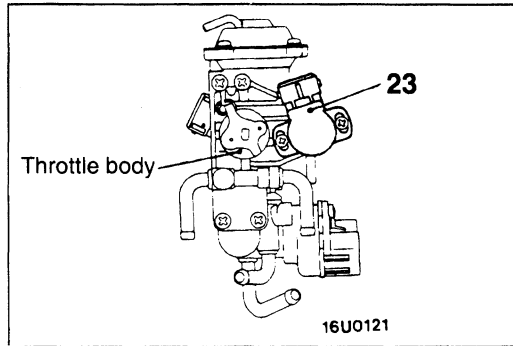
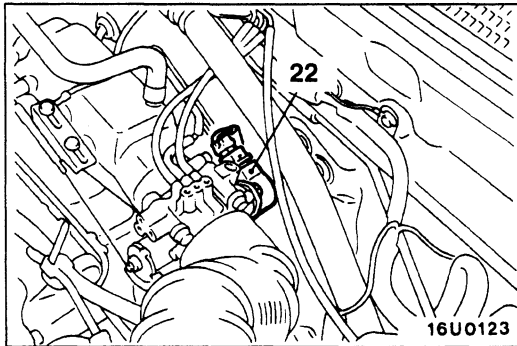

07U0006

00003540

Sensor removal

- 22. Throttle position sensor
- 23. Accelerator pedal position sensor
<Vehicles with TCL>
- 24. Inhibitor switch <A/T>
- 25. Stop lamp switch
- 26. Clutch switch <M/T>

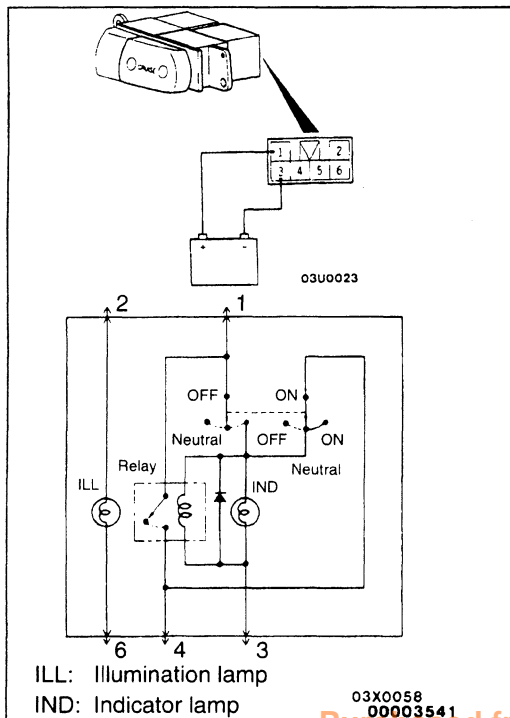

INSPECTION

17200110058

AUTO-CRUISE CONTROL MAIN SWITCH CHECK

1. When the battery (+) side is connected to terminal 1 and the (-) side is connected to terminal 3, and the main switch is turned to ON, check if battery voltage is output between terminal 4 and the earth until the main switch is turned to OFF. Next, when the main switch is turned to OFF, check if the battery voltage that was output between terminal 4 and the earth becomes 0V.
2. Check the continuity between terminals 2 and 6.

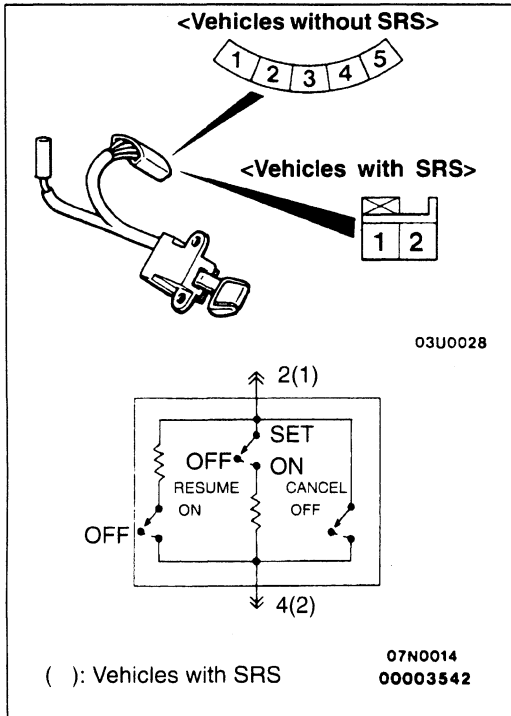

AUTO-CRUISE CONTROL SWITCH CHECK

17200120051

Measure the resistance between the terminals when each of the SET, RESUME and CANCEL switches is pressed. If the values measured at this time correspond to those in the table below, then there is no problem.

Switch position	Resistance between terminals
Switch OFF	No continuity
CANCEL switch ON	Approx. 0 Ω
RESUME switch ON	Approx. 820 Ω
SET switch ON	Approx. 2,700 Ω

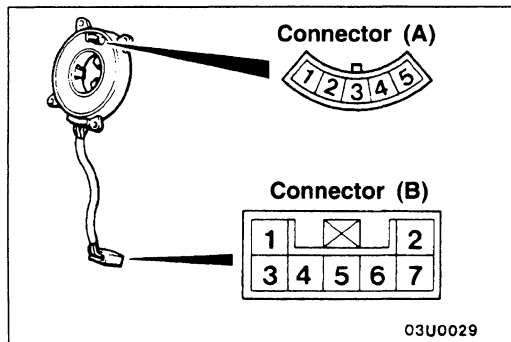

SLIP RING CHECK

17200180028

Terminal used	Connector (A) terminal No.					Connector (B) terminal No.				
	1	2	3	4	5	1	2	3	6	7
ACC power supply		○				○				
Earth					○					○
Auto-cruise control				○					○	
Horn	○						○			

NOTE

1. Check to be sure that there is no change in continuity when the steering wheel is turned.
2. For vehicles with SRS, refer to GROUP 52B – Clock Spring.

EMISSION CONTROL SYSTEM

17300010047

GENERAL INFORMATION

The emission control system consists of the following subsystems:

- Crankcase emission control system
- Evaporative emission control system
- Exhaust emission control system

Items	Name	Specification
Crankcase emission control system	Positive crankcase ventilation (PCV) valve	Variable flow type (Purpose: HC reduction)
Evaporative emission control system	Canister Purge control solenoid valve	Equipped ON/OFF type solenoid valve (Purpose: HC reduction)
Exhaust emission control system	Air-fuel ratio control device–MPI system	Oxygen sensor feedback type (Purpose: CO, HC, NOx reduction)
	Exhaust gas recirculation system <ul style="list-style-type: none"> • EGR valve • EGR control solenoid valve 	Equipped Single type Duty cycle type solenoid valve (Purpose: NOx reduction)
	Catalytic converter	Monolith type (Purpose: CO, HC, NOx reduction)

EMISSION CONTROL DEVICE REFERENCE TABLE

Related parts	Crankcase emission control system	Evaporative emission control system	Air/fuel ratio control system	Catalytic converter	Exhaust gas recirculation system	Reference page
PCV valve	×					17-37
Purge control solenoid valve		×				17-40
MPI system component		×	×			GROUP 13A
Catalytic converter				×		17-45
EGR valve					×	17-42
EGR control solenoid valve					×	17-44

SERVICE SPECIFICATIONS

17300030043

Items	Standard value
Purge control solenoid valve coil resistance (at 20°C) Ω	62–74
EGR control solenoid valve coil resistance (at 20°C) Ω	62–74

VACUUM HOSE

17300090041

VACUUM HOSE PIPING DIAGRAM

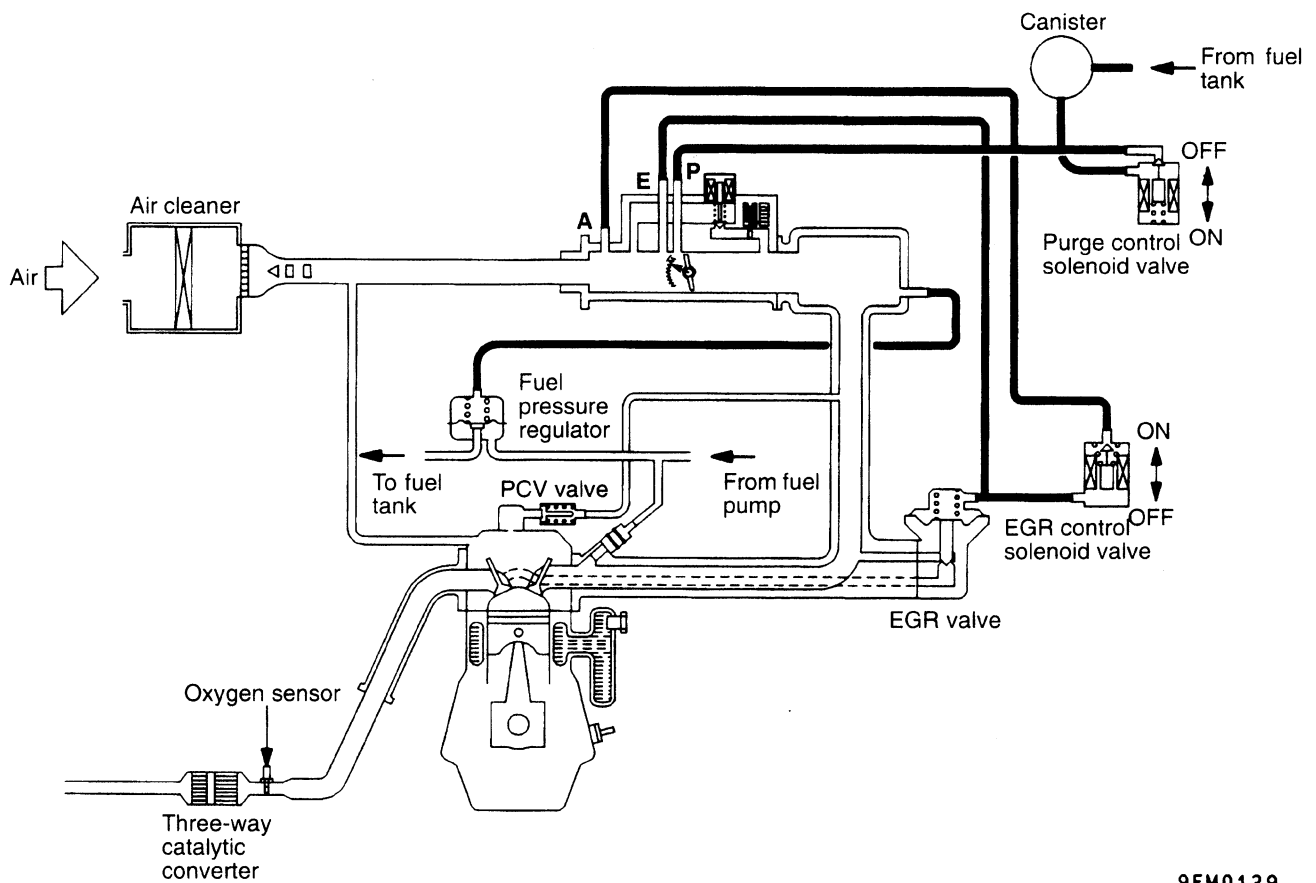

9EM0129

17-34 ENGINE AND EMISSION CONTROL – Emission Control System

VACUUM CIRCUIT DIAGRAM

<Vehicles without TCL>

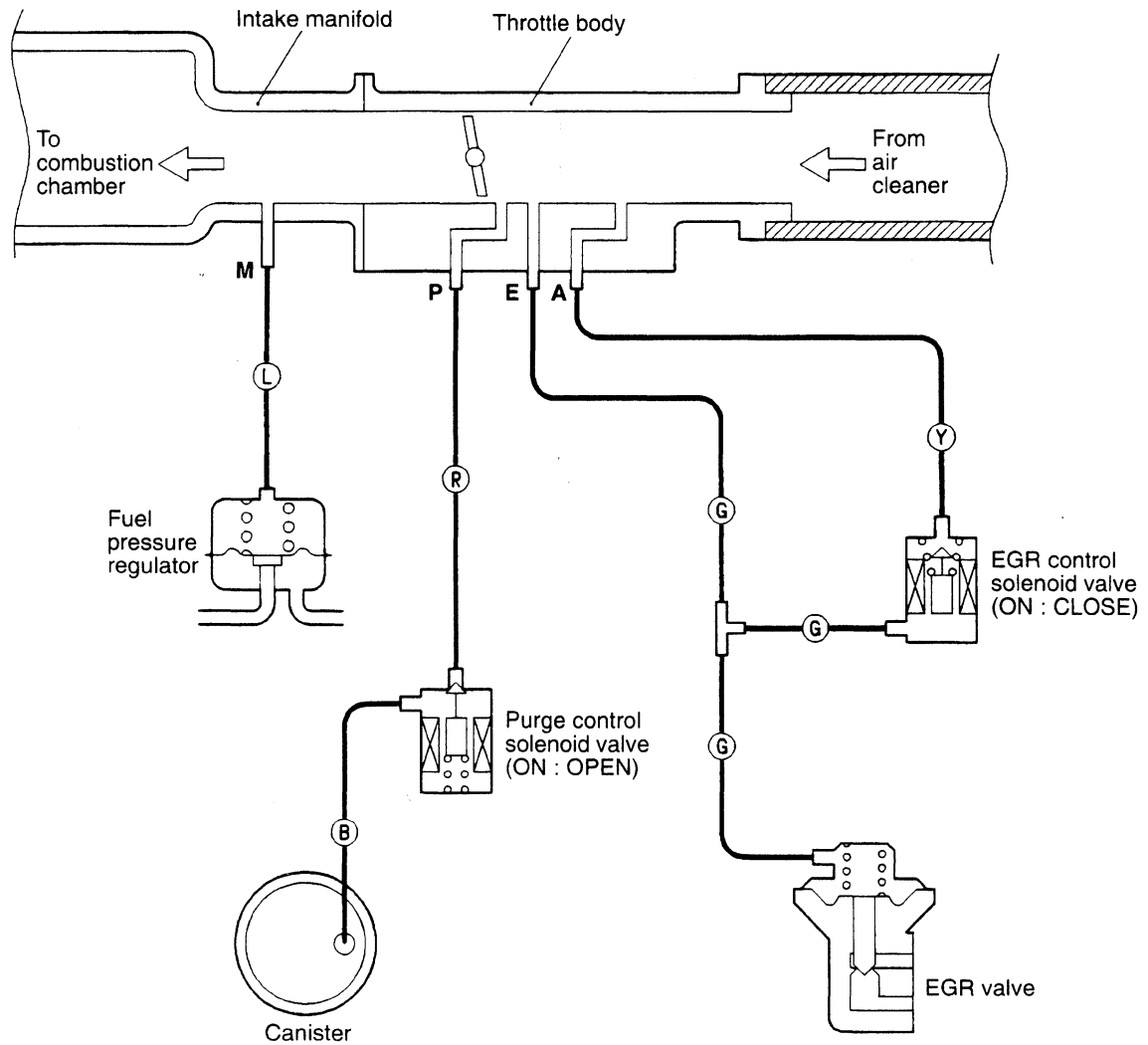

9EM0131

Vacuum hose colour

- B: Black
- G: Green
- L: Light blue
- R: Red
- Y: Yellow

<Vehicles with TCL>

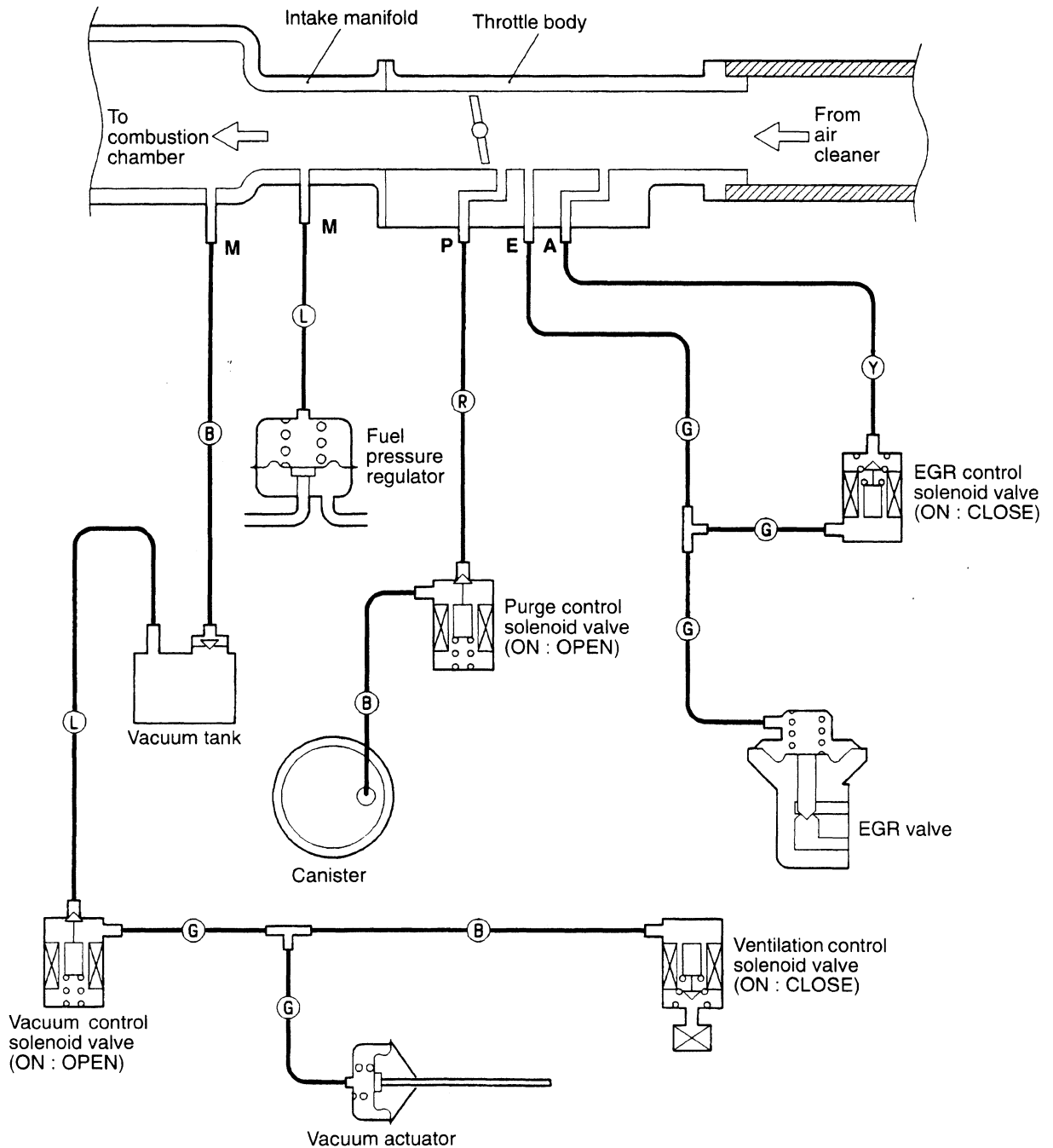

- Vacuum hose colour**
- G: Green
 - Y: Yellow
 - L: Light blue
 - R: Red
 - B: Black

9EM0132

VACUUM HOSE CHECK

1. Using the piping diagram as a guide, check to be sure that the vacuum hoses are correctly connected.
2. Check the connection condition of the vacuum hoses, (removed, loose, etc.) and check to be sure that there are no bends or damage.

VACUUM HOSE INSTALLATION

1. When connecting the vacuum hoses, they should be securely inserted onto the nipples.
2. Connect the hoses correctly, using the vacuum hose piping diagram as a guide.

CRANKCASE EMISSION CONTROL SYSTEM

17300500049

GENERAL INFORMATION

The crankcase emission control system prevents blow-by gases from escaping inside the crankcase into the atmosphere.

Fresh air is sent from the air cleaner into the crankcase through the breather hose. The air becomes mixed with the blow-by gases inside the crankcase.

The blow-by gas inside the crankcase is drawn into the intake manifold through the positive

crankcase ventilation valve.

The positive crankcase ventilation valve lifts the plunger according to the intake manifold vacuum so as to regulate the flow of blow-by gas properly. In other words, the blow-by gas flow is regulated during low load engine operation to maintain engine stability, while the flow is increased during high load operation to improve the ventilation performance.

SYSTEM DIAGRAM

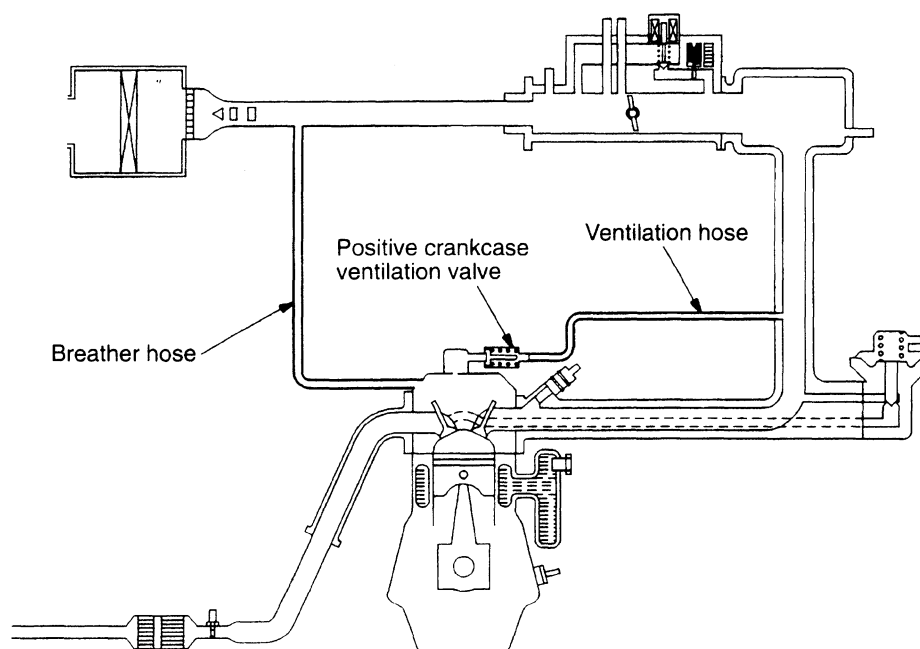

9EM0133

COMPONENT LOCATION

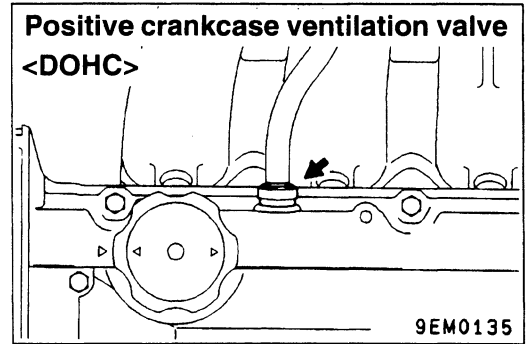
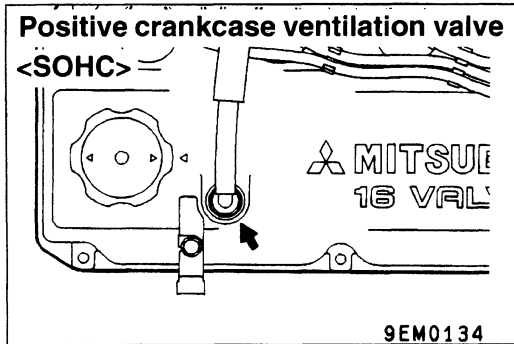

POSITIVE CRANKCASE VENTILATION SYSTEM CHECK

17300110044

1. Remove the ventilation hose from the positive crankcase ventilation valve.
2. Remove the positive crankcase ventilation valve from the rocker cover.
3. Reinstall the positive crankcase ventilation valve at the ventilation hose.
4. Start the engine and run at idle.
5. Place a finger at the opening of the positive crankcase ventilation valve and check that vacuum of the intake manifold is felt.

NOTE

At this moment, the plunger in the positive crankcase ventilation valve moves back and forth.

6. If vacuum is not felt, clean the positive crankcase ventilation valve or replace it.

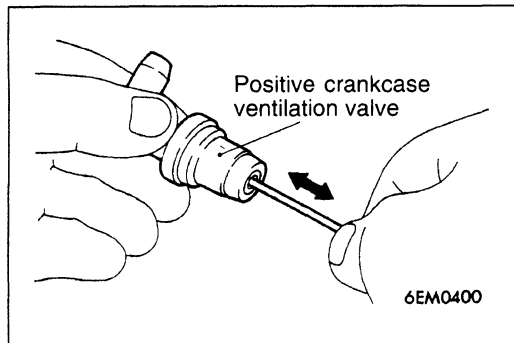
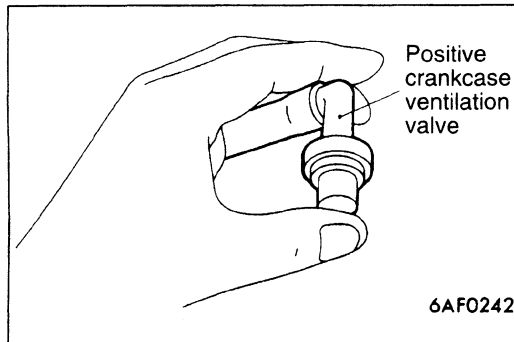

PCV VALVE CHECK

17300120047

1. Insert a thin rod into the positive crankcase ventilation valve from the side shown in the illustration (rocker cover installation side), and move the rod back and forth to check that the plunger moves.
2. If the plunger does not move, there is a clogging in the positive crankcase ventilation valve. In this case, clean or replace the valve.

EVAPORATIVE EMISSION CONTROL SYSTEM

17300510059

GENERAL INFORMATION

The evaporative emission control system prevents fuel vapours generated in the fuel tank from escaping into the atmosphere.

Fuel vapours from the fuel tank flow through the fuel tank pressure control valve and vapour pipe/hose to be stored temporarily in the canister. When driving the vehicle, fuel vapours stored in the canister flow through the purge solenoid and purge port and go into the intake manifold to be

sent to the combustion chamber.

When the engine coolant temperature is low or when the intake air quantity is small (when the engine is at idle, for example), the engine control unit turns the purge solenoid off to shut off the fuel vapour flow to the intake manifold.

This does not only insure the driveability when the engine is cold or running under low load but also stabilize the emission level.

SYSTEM DIAGRAM

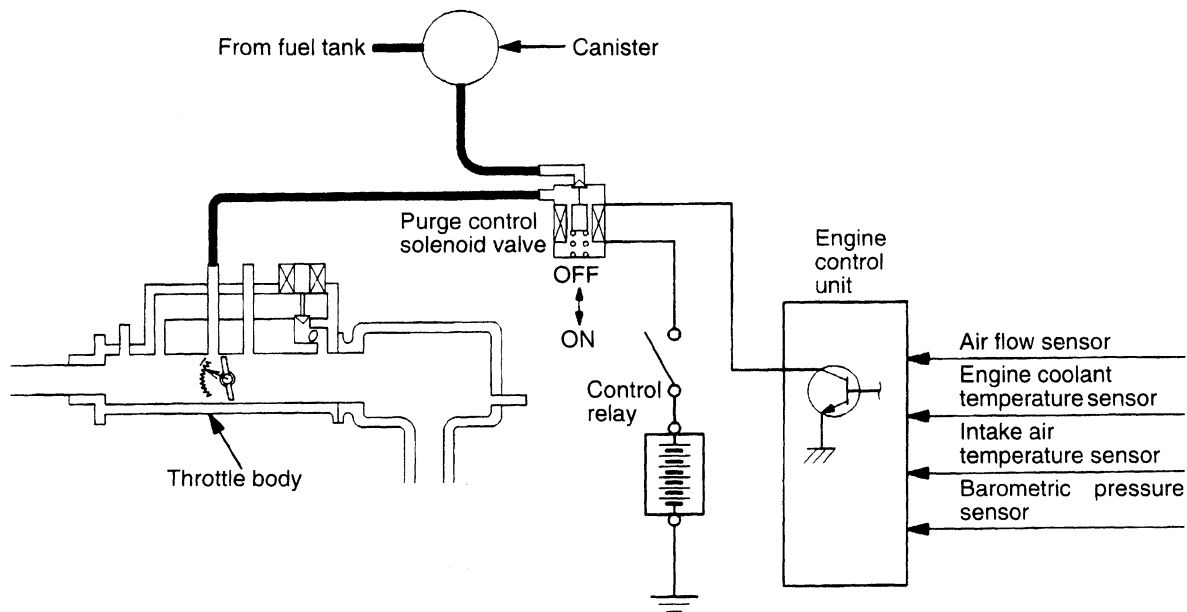

6FU2235

COMPONENT LOCATION

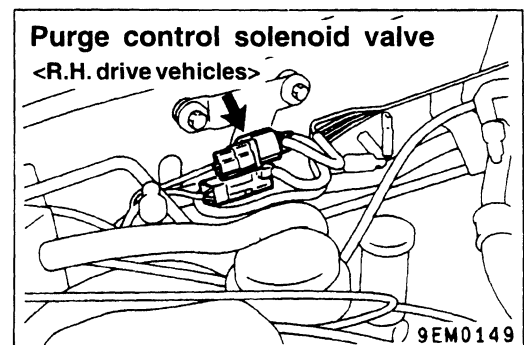
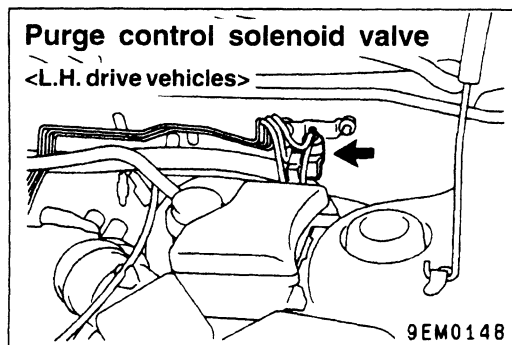

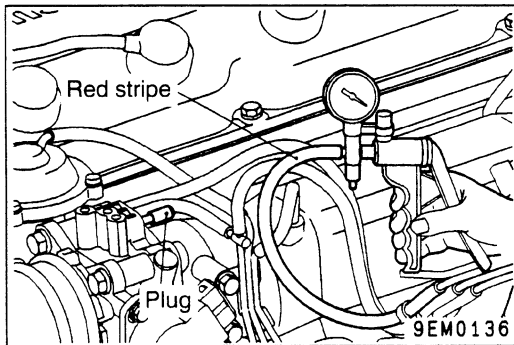

PURGE CONTROL SYSTEM CHECK

17300140043

1. Disconnect the vacuum hose (red stripe) from the throttle body and connect it to a hand vacuum pump.
2. Plug the nipple from which the vacuum hose was removed.
3. When the engine is cold or hot, apply a vacuum while the engine is idling, and check the condition of the engine and the vacuum.

**When engine is cold
(Engine coolant temperature: 40°C or less)**

Vacuum	Engine condition	Normal condition
53 kPa	3,000 r/min	Vacuum is maintained

**When engine is hot
(Engine coolant temperature: 80°C or higher)**

Vacuum	Engine condition	Normal condition
53 kPa	At idle	Vacuum is maintained
	3,000 r/min	Vacuum will leak for approximately 3 minutes after the engine is started. After 3 minutes have passed, the vacuum will be maintained momentarily, after which it will again leak.*

NOTE

*: The vacuum will leak continuously if the atmospheric pressure is approximately 77 kPa or less, or the temperature of the intake air is approximately 50°C or higher.

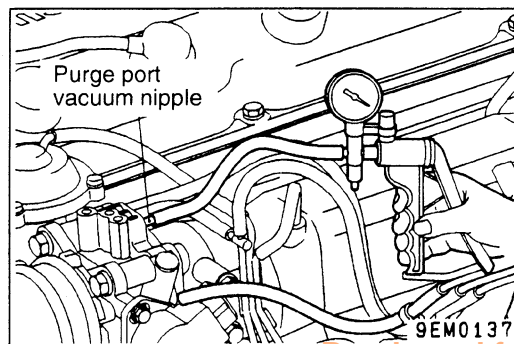

PURGE PORT VACUUM CHECK

17300150046

1. Disconnect the vacuum hose (red stripe) from the throttle body purge vacuum nipple and connect a hand vacuum pump to the nipple.

17-40 ENGINE AND EMISSION CONTROL – Emission Control System

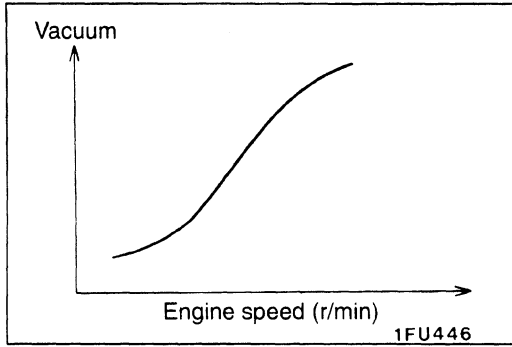

2. Start the engine and check that, after raising the engine speed by racing the engine, purge vacuum raises according to engine speed.

NOTE

If there is a problem with the change in vacuum, the throttle body purge port may be clogged and require cleaning.

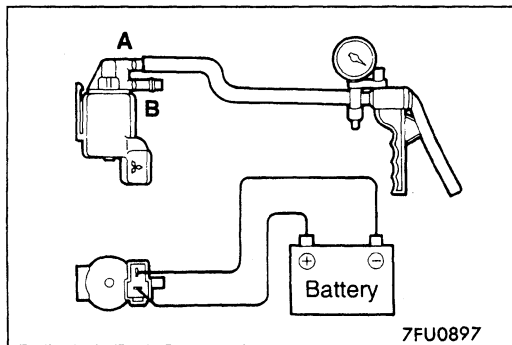

PURGE CONTROL SOLENOID VALVE CHECK

17300170042

NOTE

When disconnecting the vacuum hose, always make a mark so that it can be reconnected at original position.

1. Disconnect the vacuum hose (black stripe, red stripe) from the solenoid valve.
2. Disconnect the harness connector.
3. Connect a hand vacuum pump to nipple (A) of the solenoid valve (refer to the illustration at left).
4. Check airtightness by applying a vacuum with voltage applied directly from the battery to the purge control solenoid valve and without applying voltage.

Battery voltage	Normal condition
Applied	Vacuum leaks
Not applied	Vacuum maintained

5. Measure the resistance between the terminals of the solenoid valve.

Standard value: 62–74 Ω (at 20°C)

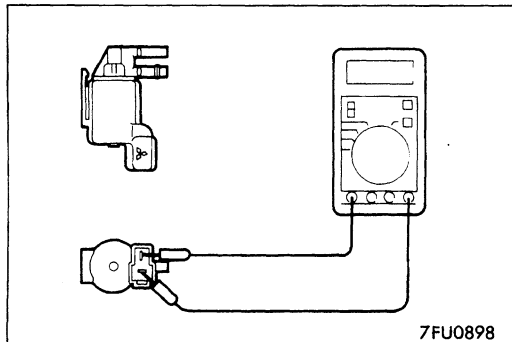

EXHAUST GAS RECIRCULATION (EGR) SYSTEM

17300520045

GENERAL INFORMATION

The exhaust gas recirculation (EGR) system lowers the nitrogen oxide (NOx) emission level. When the air/fuel mixture combustion temperature is high, a large quantity of nitrogen oxides (NOx) is generated in the combustion chamber. Therefore, this system recirculates part of emission gas from

the exhaust port of the cylinder head to the combustion chamber through the intake manifold to decrease the air/fuel mixture combustion temperature, resulting in reduction of NOx. The EGR flow rate is controlled by the EGR valve so as not to decrease the driveability.

OPERATION

The EGR valve is being closed and does not recirculate exhaust gases under one of the following conditions. Otherwise, the EGR valve is opened and recirculates exhaust gases.

- The engine coolant temperature is low.
- The engine is at idle.
- The throttle valve is widely opened.

SYSTEM DIAGRAM

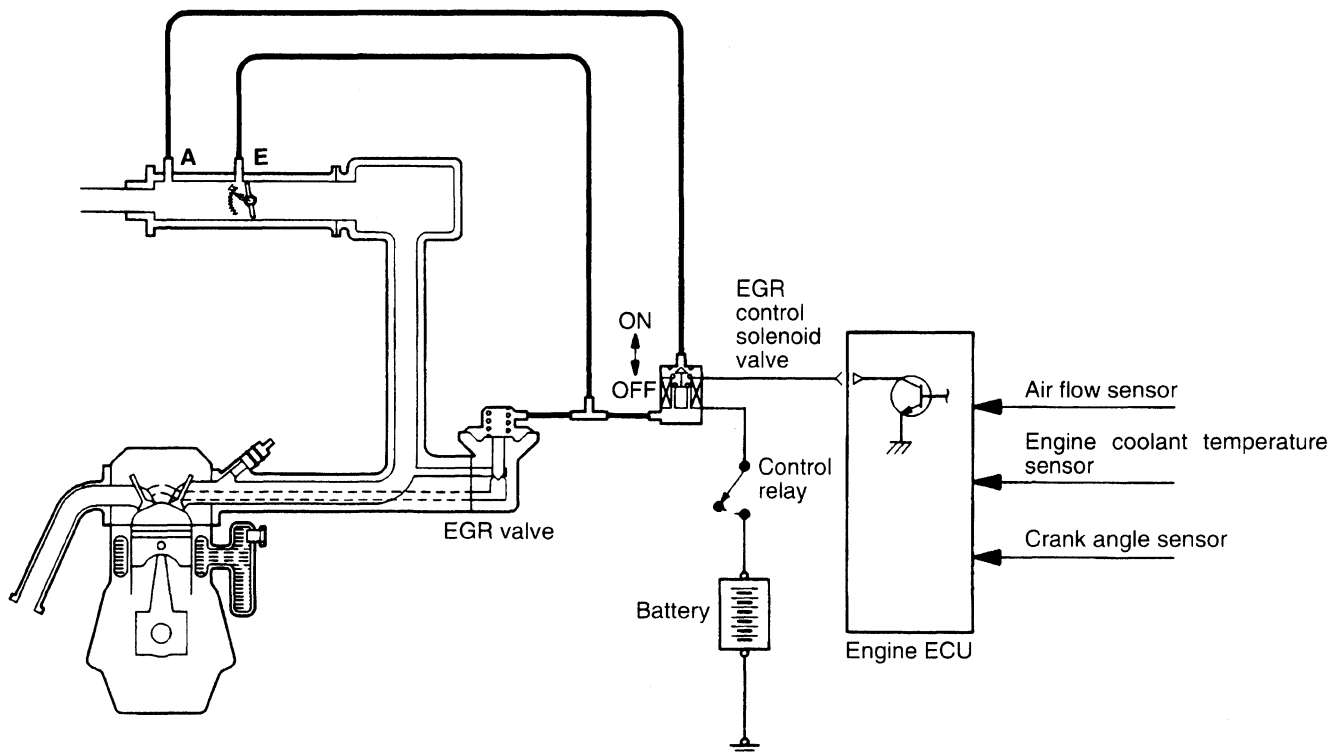

9EM0130

COMPONENT LOCATION

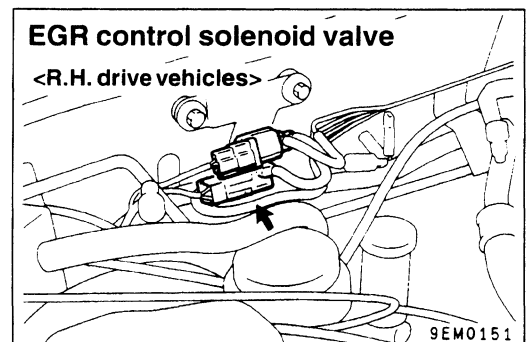
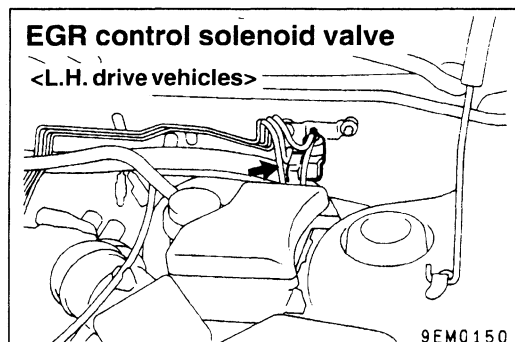

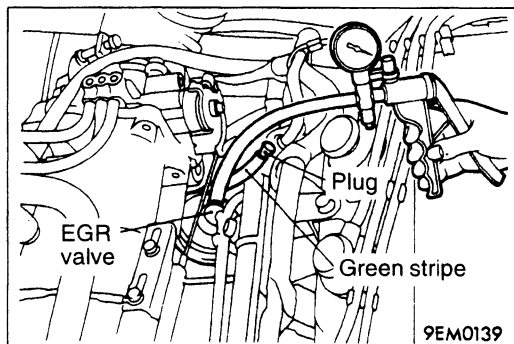
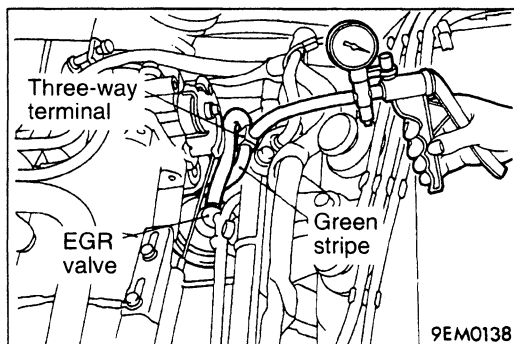
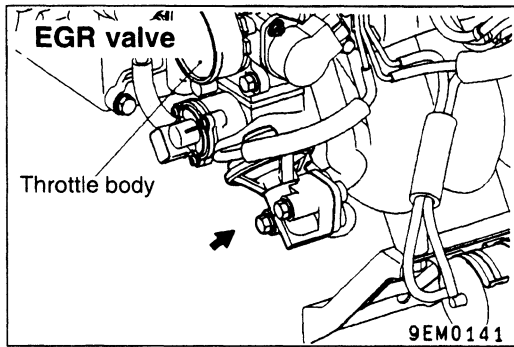

EXHAUST GAS RECIRCULATION (EGR) CONTROL SYSTEM CHECK

17300260053

1. Disconnect the vacuum hose (green stripe) from the EGR valve, and then connect a hand vacuum pump via the three-way terminal.
2. When the engine is hot or cold, check the condition of vacuum by racing the engine.

**When engine is cold
(Engine coolant temperature: 20°C or less)**

Throttle valve	Normal vacuum condition
Open quickly	No vacuum will generate (the same as barometric pressure.)

**When engine is hot
(Engine coolant temperature: 80°C or higher)**

Throttle valve	Normal vacuum condition
Open quickly	It will momentarily rise over 13 kPa

3. Disconnect the three-way terminal.
4. Connect the hand vacuum pump to the EGR valve.
5. Check whether the engine stalls or the idling is unstable when a vacuum of 30 kPa or higher is applied during idling.

EGR VALVE CHECK

17300280042

1. Remove the EGR valve and inspect for sticking, carbon deposits, etc. If found, clean with a suitable solvent so that the valve seats correctly.
2. Connect a hand vacuum pump to the EGR valve.
3. Apply 67 kPa of vacuum, and check that the vacuum is maintained.

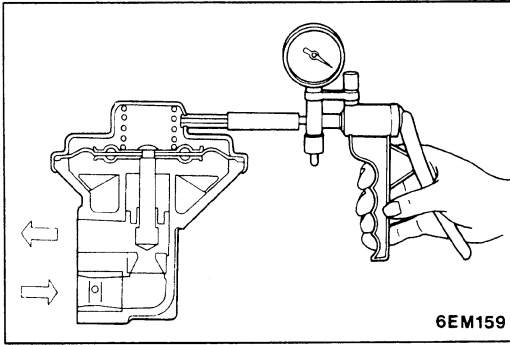

4. Apply a vacuum and check the passage of air by blowing through one side of the EGR passage.

Vacuum	Passage of air
5.3 kPa or less	Air is not blown out
26 kPa or more	Air is blown out

5. Replace the gasket, and tighten to the specified torque.
Specified torque: 22 Nm

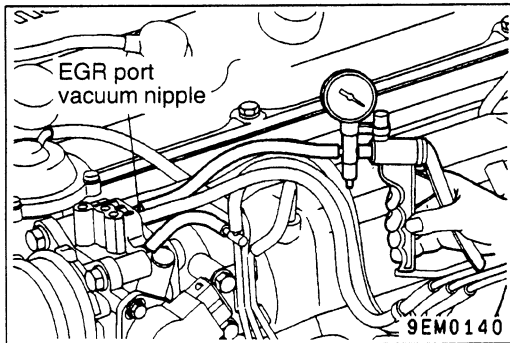

EGR PORT VACUUM CHECK

17300290045

1. Disconnect the vacuum hose (green stripe) from the throttle body EGR vacuum nipple and connect a hand vacuum pump to the nipple.

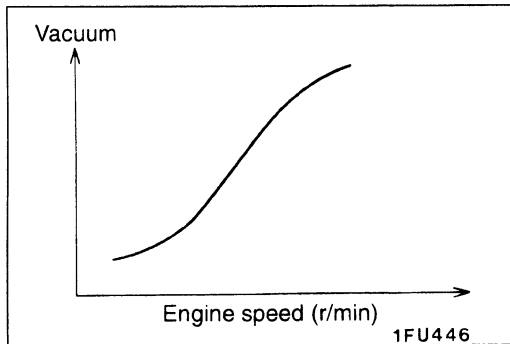

2. Start the engine and check to see that, after raising the engine speed by racing the engine, EGR vacuum raises proportionately with the rise in engine speed.

NOTE

If there is a problem with the change in vacuum, it is possible that the throttle body EGR port may be clogged and require cleaning.

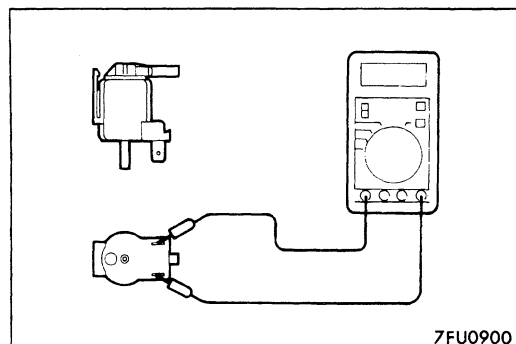
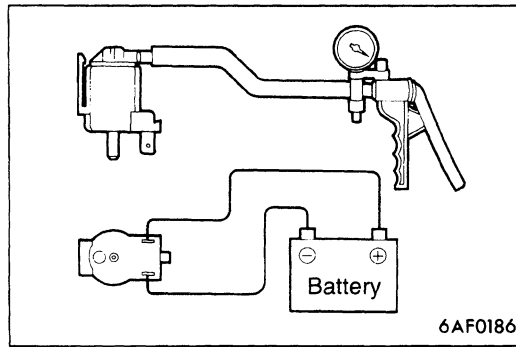

EGR CONTROL SOLENOID VALVE CHECK

17300310048

NOTE

When disconnecting the vacuum hose, always make a mark so that it can be reconnected at original position.

1. Disconnect the vacuum hose (yellow stripe, green stripe) from the solenoid valve.
2. Disconnect the harness connector.
3. Connect a hand vacuum pump to the nipple to which the green-striped vacuum hose was connected.
4. Check airtightness by applying a vacuum with voltage applied directly from the battery to the EGR control solenoid valve and without applying voltage.

Battery voltage	Normal condition
Not applied	Vacuum leaks
Applied	Vacuum maintained

5. Measure the resistance between the terminals of the solenoid valve.

Standard value: 62–74Ω (at 20°C)

CATALYTIC CONVERTER

17300530055

GENERAL INFORMATION

The three-way catalytic converter, together with the closed loop air-fuel ratio control based on the oxygen sensor signal, oxidizes carbon monoxides (CO) and hydrocarbons (HC) and reduces nitrogen oxides (NOx).

When the mixture is controlled at stoichiometric air-fuel ratio, the three-way catalytic converter provides the highest purification against the three constituents, namely, CO, HC and NOx.

REMOVAL AND INSTALLATION

17300390042

Pre-removal and Post-installation Operation
 • Under Cover Removal and Installation

<SOHC>

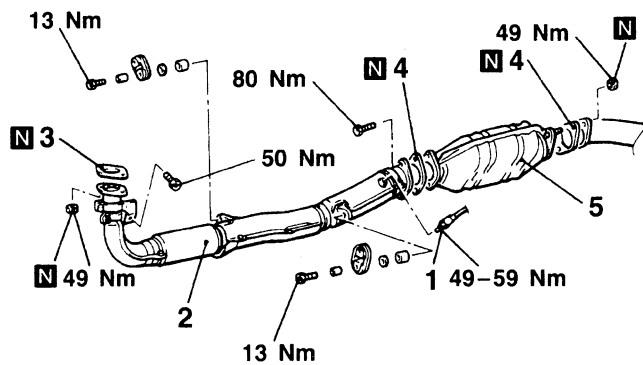

<DOHC>

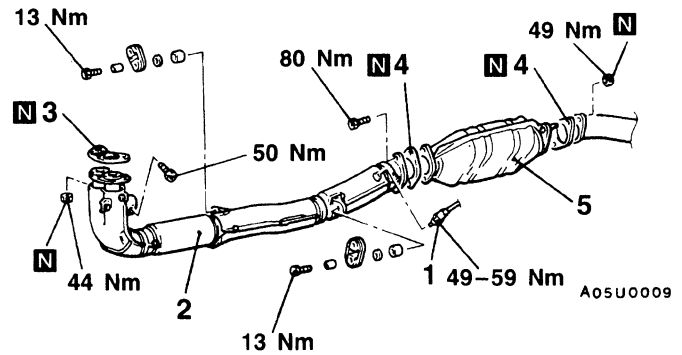

Removal steps

1. Oxygen sensor
2. Front exhaust pipe
3. Gasket
4. Gasket
5. Catalytic converter

CANISTER

17300420024

REMOVAL AND INSTALLATION

Pre-removal and Post-installation Operation
 • Air Cleaner, Air Intake Hose Removal and Installation

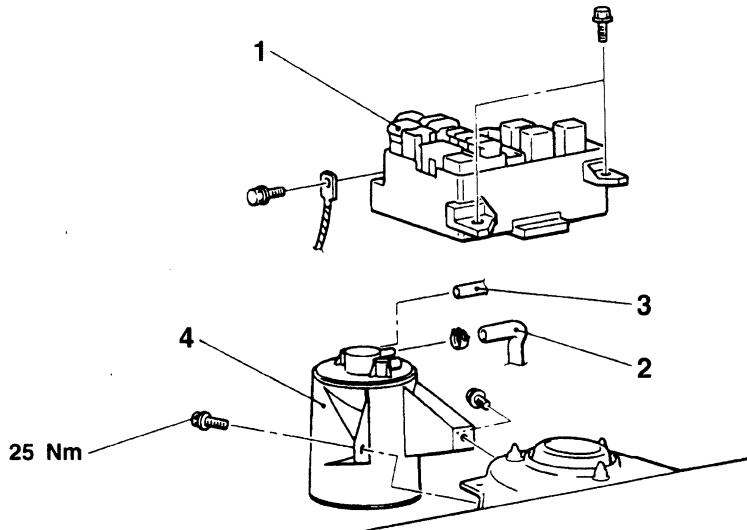

A03U0012

Removal steps

1. Relay box
2. Vapor hose
3. Purge hose
4. Canister

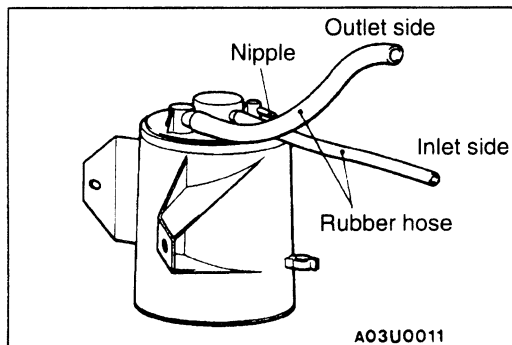

A03U0011

INSPECTION

17300430027

SIMPLE INSPECTION OF CHECK VALVE INSIDE CANISTER

1. Connect clean rubber hoses to the nipples on the inlet side and outlet side.
2. Close off the other nipple with your finger and then check the operation of the check valve.

Inspection procedure	Normal condition
Lightly blow from inlet side (fuel tank side).	Air passes through with a slight feeling of resistance.
Lightly blow from outlet side (atmosphere side).	Air passes through.