

ENGINE ELECTRICAL

CONTENTS

1610900035

| | | | |
|--|-----------|---|-----------|
| CHARGING SYSTEM | 2 | SPECIAL TOOL | 30 |
| GENERAL INFORMATION | 2 | ON-VEHICLE SERVICE | 30 |
| SERVICE SPECIFICATIONS | 3 | Ignition Coil Check | 30 |
| SPECIAL TOOL | 4 | Power Transistor Continuity Check <SOHC> | 30 |
| ON-VEHICLE SERVICE | 4 | Ignition Coil (With Built-in Power Transistor) Check <DOHC> | 31 |
| Alternator Output Line Voltage Drop Test ... | 4 | Ignition Failure Sensor Check <DOHC> | 31 |
| Output Current Test | 5 | Resistive Cord Check | 32 |
| Regulated Voltage Test | 7 | Detonation Sensor Check | 32 |
| Waveform Check Using An Analyzer | 9 | Spark Plug Check and Cleaning | 32 |
| ALTERNATOR | 11 | Crank Angle Sensor, Top Dead Center Sensor <SOHC>/Camshaft Position Sensor, Crankshaft Position Sensor <DOHC> Check | 33 |
| STARTING SYSTEM | 14 | Waveform Check Using An Analyzer | 33 |
| GENERAL INFORMATION | 14 | DISTRIBUTOR <SOHC> | 42 |
| SERVICE SPECIFICATIONS | 15 | IGNITION SYSTEM <DOHC> | 44 |
| STARTER MOTOR | 16 | CAMSHAFT POSITION SENSOR AND CRANKSHAFT POSITION SENSOR <DOHC> | 45 |
| IGNITION SYSTEM | 27 | DETONATION SENSOR | 46 |
| GENERAL INFORMATION | 27 | | |
| SERVICE SPECIFICATIONS | 29 | | |

CHARGING SYSTEM

16100010037

GENERAL INFORMATION

The charging system uses the alternator output to keep the battery charged at a constant level under various electrical loads.

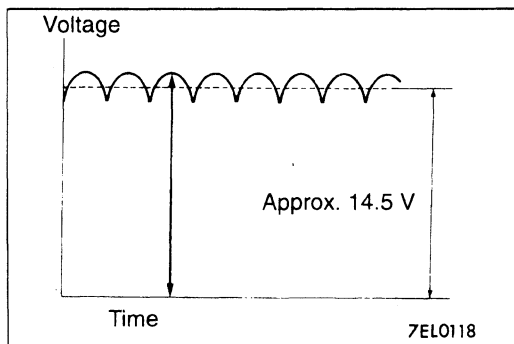

OPERATION

Rotation of the excited field coil generates AC voltage in the stator.

This alternating current is rectified through diodes to DC voltage having a waveform shown in the illustration at left. The average output voltage fluctuates slightly with the alternator load condition.

When the ignition switch is turned on, current flows in the field coil and initial excitation of the field coil occurs. The alternator output voltage rises as the field current increases and it falls as the field current decreases. When the battery voltage (alternator S terminal voltage) reaches a regulated voltage of approx. 14.4 V, the field current is cut off. When

the battery voltage drops below the regulated voltage, the voltage regulator regulates the output voltage to a constant level by controlling the field current.

In addition, when the field current is constant, the alternator output voltage rises as the engine speed increases.

SYSTEM DIAGRAM

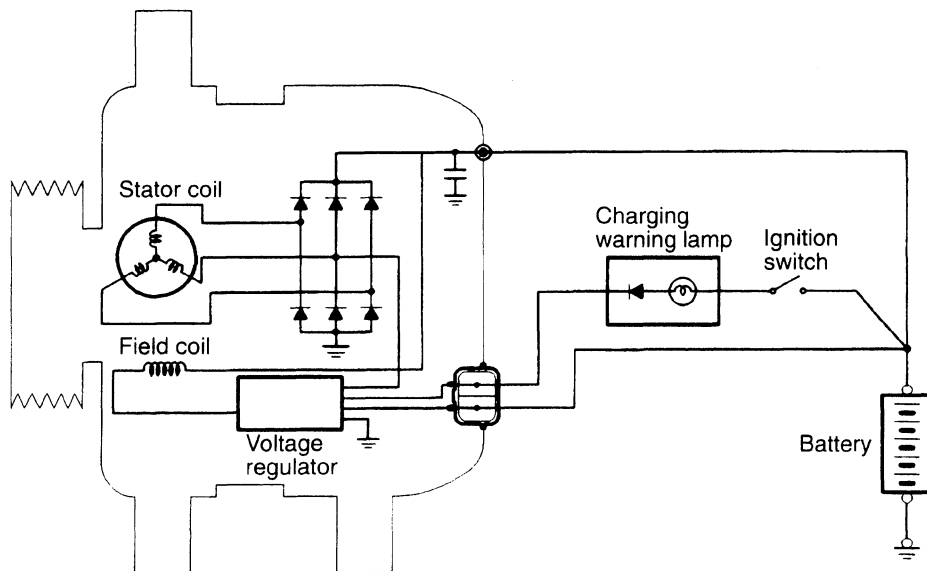

9EN0552

ALTERNATOR SPECIFICATIONS

| | | |
|-------------------|--------------------------|--------------------------|
| Items | Only 1.6L-M/T | Except 1.6L-M/T |
| Type | Battery voltage sensing | Battery voltage sensing |
| Rated output V/A | 12/70 | 12/90 |
| Voltage regulator | Electronic built-in type | Electronic built-in type |

SERVICE SPECIFICATIONS

16100030033

| Items | | Standard value | Limit |
|--|-------|----------------|------------------------------|
| Alternator output line voltage drop (at 30A) V | | – | max. 0.3 |
| Regulated voltage ambient temp. at voltage regulator V | –20°C | 14.2–15.4 | – |
| | 20°C | 13.9–14.9 | – |
| | 60°C | 13.4–14.6 | – |
| | 80°C | 13.1–14.5 | – |
| Output current | | – | 70% of normal output current |
| Rotor coil resistance | | Approx. 2.6 | – |

SPECIAL TOOL

1610060025

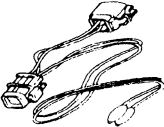
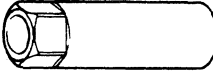
| Tool | Number | Name | Use |
|---|----------|------------------------------|--|
|  | MD998467 | Alternator harness connector | Checking the alternator (S terminal voltage) |
|  | MD998703 | Oxygen sensor wrench | Alternator pulley removal and installation |

ON-VEHICLE SERVICE

1610090031

ALTERNATOR OUTPUT LINE VOLTAGE DROP TEST

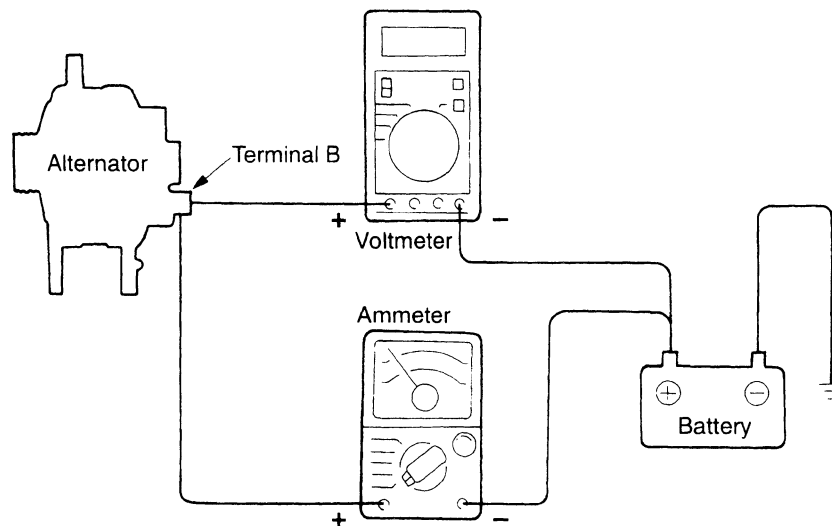

5EL0015

This test determines whether the wiring from the alternator "B" terminal to the battery (+) terminal (including the fusible line) is in a good condition or not.

- (1) Always be sure to check the following before the test.
 - Alternator installation
 - Alternator drive belt tension (Refer to GROUP 11A – On-vehicle Service.)
 - Fusible link
 - Abnormal noise from the alternator while the engine is running
- (2) Turn the ignition switch off.
- (3) Disconnect the negative battery cable.
- (4) Disconnect the alternator output wire from the alternator "B" terminal and connect a DC test ammeter with a range of 0–100 A in series between the "B" terminal and the disconnected

output wire. (Connect the (+) lead of the ammeter to the "B" terminal, and then connect the (–) lead of the ammeter to the disconnected output wire.)

NOTE

An inductive-type ammeter which enables measurements to be taken without disconnecting the alternator output wire should be recommended. Using this equipment will lessen the possibility of a voltage drop caused by a loose "B" terminal connection.

- (5) Connect a digital-type voltmeter between the alternator "B" terminal and the battery (+) terminal. (Connect the (+) lead of the voltmeter to the "B" terminal and the connect the (–) lead of the voltmeter to the battery (+) cable.)

- (6) Connect a tachometer. (For the procedure for connecting the tachometer, refer to GROUP 11A – On-vehicle Service.)
- (7) Reconnect the negative battery cable.
- (8) Leave the hood open.
- (9) Start the engine.
- (10) With the engine running at 2,500 r/min, turn the headlamps and other lamps on and off to adjust the alternator load so that the value displayed on the ammeter is slightly above 30 A.
Adjust the engine speed by gradually decreasing it until the value displayed on the ammeter is 30 A. Take a reading of the value displayed on the voltmeter at this time.

Limit: max. 0.3 V

NOTE

When the alternator output is high and the value displayed on the ammeter does not decrease until 30 A, set the value to 40 A. Read the value displayed on the voltmeter at this time.

- (11) If the value displayed on the voltmeter is above the limit value, there is probably a malfunction in the alternator output wire, so check the wiring between the alternator "B" terminal and the battery (+) terminal (including fusible link). If a terminal is not sufficiently tight or if the harness has become discolored due to overheating, repair and then test again.
- (12) After the test, run the engine at idle.
- (13) Turn all lamps and the ignition at idle.
- (14) Disconnect the negative battery cable.
- (15) Disconnect the ammeter, voltmeter and tachometer.
- (16) Connect the alternator output wire to the alternator "B" terminal.
- (17) Connect the negative battery cable.

OUTPUT CURRENT TEST

16100100031

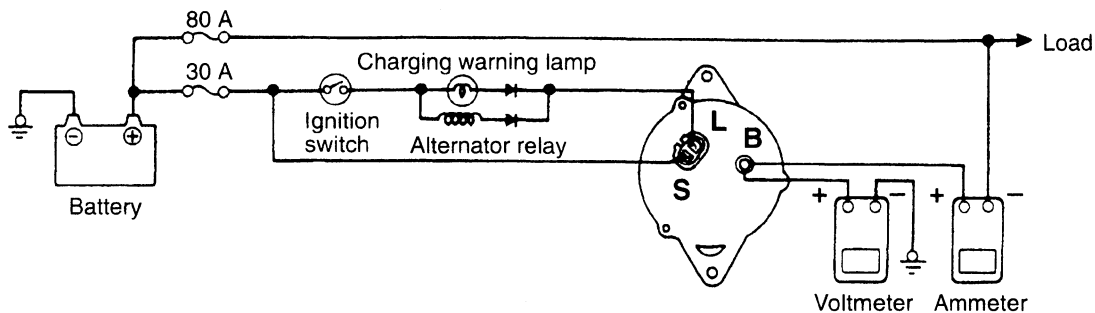

16P0482

This test determines whether the alternator output current is normal.

- (1) Before the test, always be sure to check the following.
 - Alternator installation
 - Battery (Refer to GROUP 54 – Battery.)

NOTE

The used battery should be slightly discharged. The load needed by a fully-charged battery is insufficient for an accurate test.

- Alternator drive belt tension (Refer to GROUP 11A – On-vehicle Service.)
- Fusible link
- Abnormal noise from the alternator while the engine is running.

- (2) Turn the ignition switch off.
- (3) Disconnect the negative battery cable.
- (4) Disconnect the alternator output wire from the alternator "B" terminal. Connect a DC test ammeter with a range of 0–100 A in series between the "B" terminal and the disconnected output wire. (Connect the (+) lead of the ammeter to the "B" terminal. Connect the (–) lead of the ammeter to the disconnected output wire.)

Caution

Never use clips but tighten bolts and nuts to connect the line. Otherwise loose connections (e.g. using clips) will lead to a serious accident because of high current.

NOTE

An inductive-type ammeter which enables measurements to be taken without disconnecting the alternator output wire should be recommended.

- (5) Connect a voltmeter with a range of 0–20 V between the alternator "B" terminal and the earth. (Connect the (+) lead of the voltmeter to the "B" terminal, and then connect the (–) lead of the voltmeter to the earth.)
- (6) Connect a tachometer. (For the procedure for connecting the tachometer, refer to GROUP 11A – On-vehicle Service.)
- (7) Connect the negative battery cable.
- (8) Leave the hood open.
- (9) Check that the reading on the voltmeter is equal to the battery voltage.

NOTE

If the voltage is 0 V, the cause is probably an open circuit in the wire or fusible link between the alternator "B" terminal and the battery (+) terminal.

- (10) Turn the light switch on to turn on headlamps and then start the engine.
- (11) Immediately after setting the headlamps to high beam and turning the heater blower switch to the high revolution position, increase the engine speed to 2,500 r/min and read the maximum current output value displayed on the ammeter.

Limit: 70% of normal current output

NOTE

- For the nominal current output, refer to the Alternator Specifications.
 - Because the current from the battery will soon drop after the engine is started, the above step should be carried out as quickly as possible in order to obtain the maximum current output value.
 - The current output value will depend on the electrical load and the temperature of the alternator body.
 - If the electrical load is small while testing, the specified level of current may not be output even though the alternator is normal. In such cases, increase the electrical load by leaving the headlamps turned on for some time to discharge the battery or by using the lighting system in another vehicle, and then test again.
 - The specified level of current also may not be output if the temperature of the alternator body or the ambient temperature is too high. In such cases, cool the alternator and then test again.
- (12) The reading on the ammeter should be above the limit value. If the reading is below the limit value and the alternator output wire is normal, remove the alternator from the engine and check the alternator.
 - (13) Run the engine at idle after the test.
 - (14) Turn the ignition switch off.
 - (15) Disconnect the negative battery cable.
 - (16) Disconnect the ammeter, voltmeter and tachometer.
 - (17) Connect the alternator output wire to the alternator "B" terminal.
 - (18) Connect the negative battery cable.

REGULATED VOLTAGE TEST

16100110034

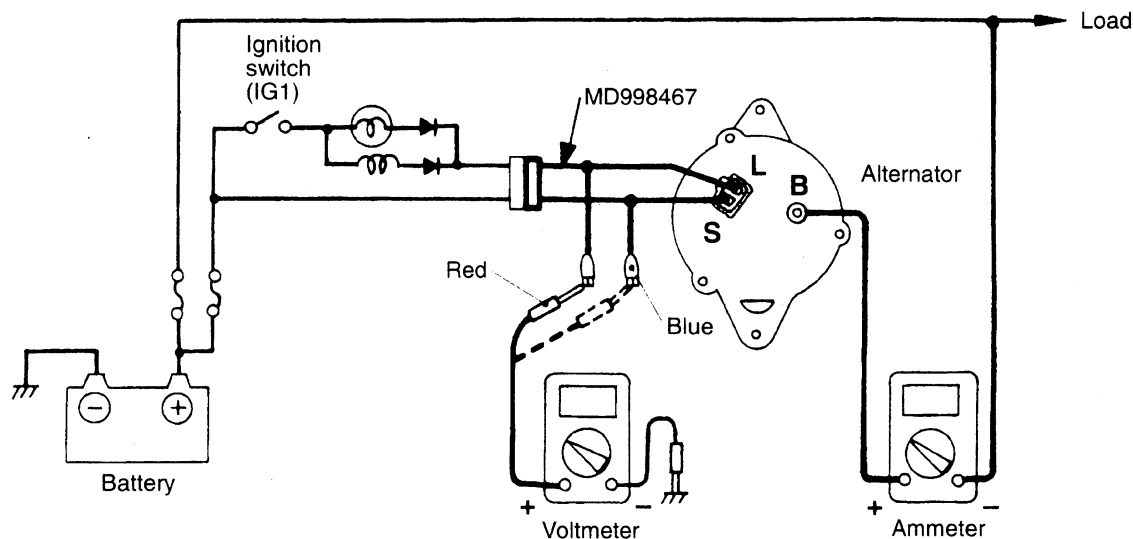

01R0467

This test determines whether the voltage regulator is correctly controlling the alternator output voltage.

(1) Always be sure to check the following before the test.

- Alternator installation
- Check that the battery installed in the vehicle is fully charged. (Refer to GROUP 54 – Battery.)
- Alternator drive belt tension (Refer to GROUP 11A – On-vehicle Service.)
- Fusible link
- Abnormal noise from the alternator while the engine is running

(2) Turn the ignition switch to the OFF position.

(3) Disconnect the negative battery cable.

(4) Connect a digital-type voltmeter between the alternator “S” terminal and the earth. (Connect the (+) lead of the voltmeter to the “S” terminal, and then connect the (–) lead of the voltmeter to a secure earth or to the battery (–) terminal.)

(5) Disconnect the alternator output wire from the alternator “B” terminal.

(6) Connect a DC test ammeter with a range of 0–100 A in series between the “B” terminal and the disconnected output wire. (Connect the (+) lead of the ammeter to the “B” terminal. Connect the (–) lead of the ammeter to the disconnected output wire.)

(7) Connect a tachometer. (Refer to GROUP 11A – On-vehicle Service.)

(8) Reconnect the negative battery cable.

(9) Turn the ignition switch to the ON position and check that the reading on the voltmeter is equal to the battery voltage.

NOTE

If the voltage is 0 V, the cause is probably an open circuit in the wire or fusible link between the alternator “S” terminal and the battery (+) terminal.

(10) Turn all lamps and accessories off.

(11) Start the engine.

(12) Increase the engine speed to 2,500 r/min.

(13) Read the value displayed on the voltmeter when the alternator output current alternator becomes 10 A or less.

16-8

ENGINE ELECTRICAL – Charging System

- (14) If the voltage reading conforms to the value in the voltage regulation, then the voltage regulator is operating normally. If the voltage is not within the standard value, there is a malfunction of the voltage regulator or of the alternator.
- (15) After the test, lower the engine speed to the idle speed.

- (16) Turn the ignition switch off.
- (17) Disconnect the negative battery cable.
- (18) Disconnect the ammeter, voltmeter and tachometer.
- (19) Connect the alternator output wire to the alternator "B" terminal.
- (20) Connect the negative battery cable.

Voltage Regulation Table

Standard value:

| Inspection terminal | Voltage regulator ambient temperature °C | Voltage V |
|---------------------|--|-----------|
| Terminal "S" | -20 | 14.2–15.4 |
| | 20 | 13.9–14.9 |
| | 60 | 13.4–14.6 |
| | 80 | 13.1–14.5 |

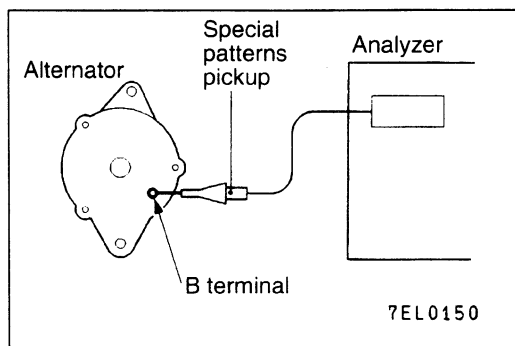

WAVEFORM CHECK USING AN ANALYZER

16100120037

MEASUREMENT METHOD

Connect the analyzer special patterns pick-up to the alternator B terminal.

STANDARD WAVEFORM

Observation Conditions

| FUNCTION | SPECIAL PATTERNS |
|------------------|------------------------------------|
| PATTERN HEIGHT | VARIABLE |
| VARIABLE knob | Adjust while viewing the waveform. |
| PATTERN SELECTOR | RASTER |
| Engine speed | Curb idle speed |

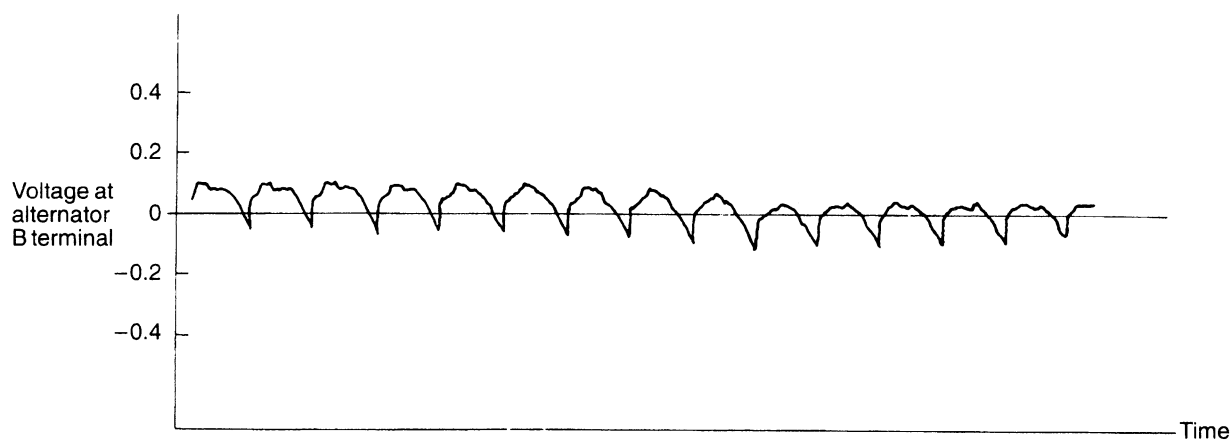

7EL0115

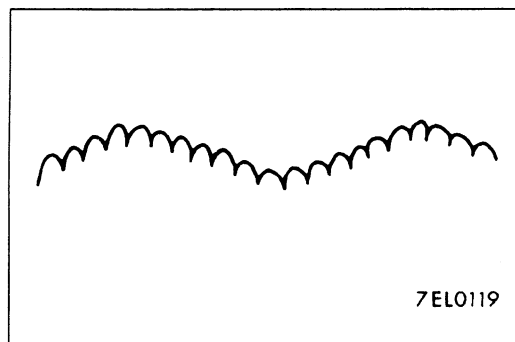





NOTE

The voltage waveform of the alternator B terminal can undulate as shown at left. This waveform is produced when the regulator operates according to fluctuations in the alternator load (current), and is normal for the alternator.

EXAMPLES OF ABNORMAL WAVEFORMS

NOTE

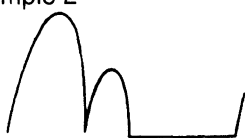
1. The size of the waveform patterns differs largely, depending on the adjustment of the variable knob on the analyzer.
2. Identification of abnormal waveforms is easier when there is a large output current (regulator is not operating). (Waveforms can be observed when the headlamps are illuminated.)
3. Check the conditions of the charging warning lamp (illuminated/not illuminated). Also, check the charging system totally.

| Abnormal waveforms | Problem cause | Abnormal waveforms | Problem cause |
|---|--|--|--|
| <p>Example 1</p>  <p style="text-align: right;">A7EL0120</p> | <ul style="list-style-type: none"> • Open diode | <p>Example 4</p>  <p style="text-align: right;">A7EL0123</p> | <ul style="list-style-type: none"> • Short in stator coil |
| <p>Example 2</p>  <p style="text-align: right;">A7EL0121</p> | <ul style="list-style-type: none"> • Short in diode | <p>Example 5</p>  <p style="text-align: right;">A7EL0124</p> | <ul style="list-style-type: none"> • Open supplementary diode |
| <p>Example 3</p>  <p style="text-align: right;">A7EL0122</p> | <ul style="list-style-type: none"> • Broken wire in stator coil | <p>At this time, the charging warning lamp is illuminated.</p> | |

ALTERNATOR

16100140071

REMOVAL AND INSTALLATION

Post-installation Operation

- Drive Belt Tension Adjustment
(Refer to GROUP 11A – On-vehicle Service.)

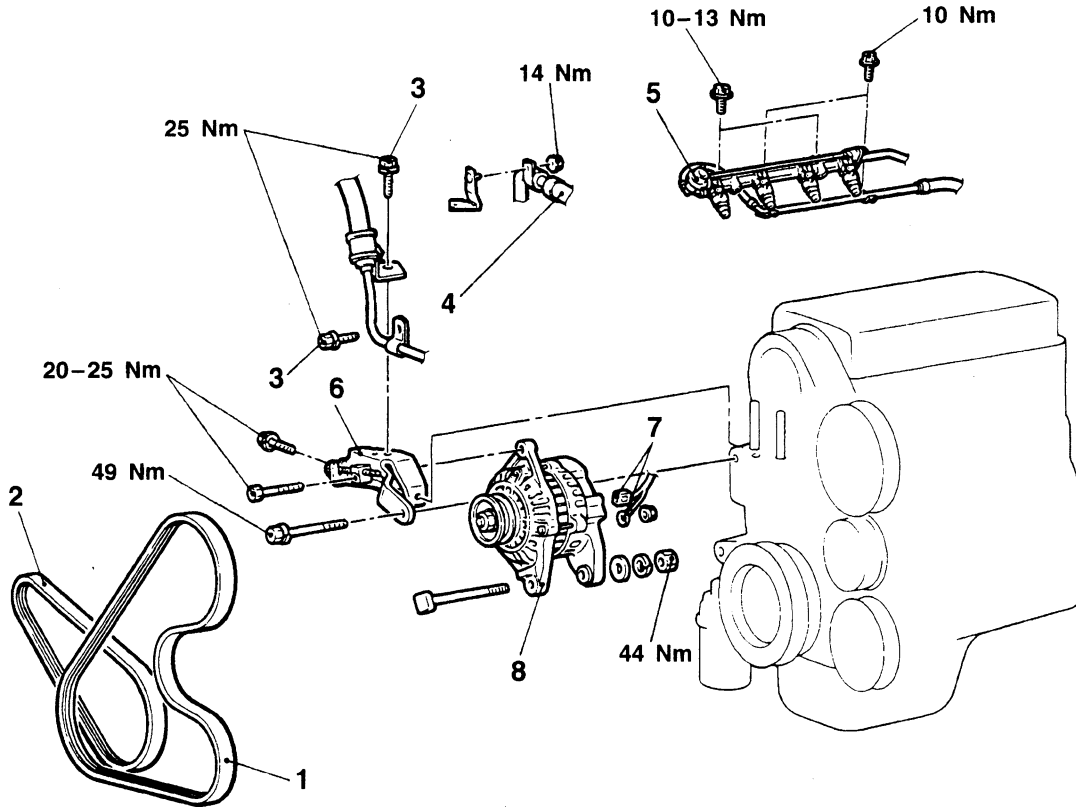

A16U0046

Removal steps

1. Drive belt (Power steering, A/C)
2. Drive belt (Alternator)
3. Oil pressure tube clamp bolts
4. A/C hose connection



5. Delivery pipe and fuel return pipe assembly <DOHC>
6. Alternator brace
7. Alternator connector
8. Alternator



REMOVAL SERVICE POINT

◀A▶ A/C HOSE CONNECTION/DELIVERY PIPE AND FUEL RETURN HOSE ASSEMBLY REMOVAL

NOTE

Move the respective parts slightly to make enough space for removal of the alternator.

Caution

Care must be taken, when removing the delivery pipe, not to drop the injector.

DISASSEMBLY AND REASSEMBLY

16100160084

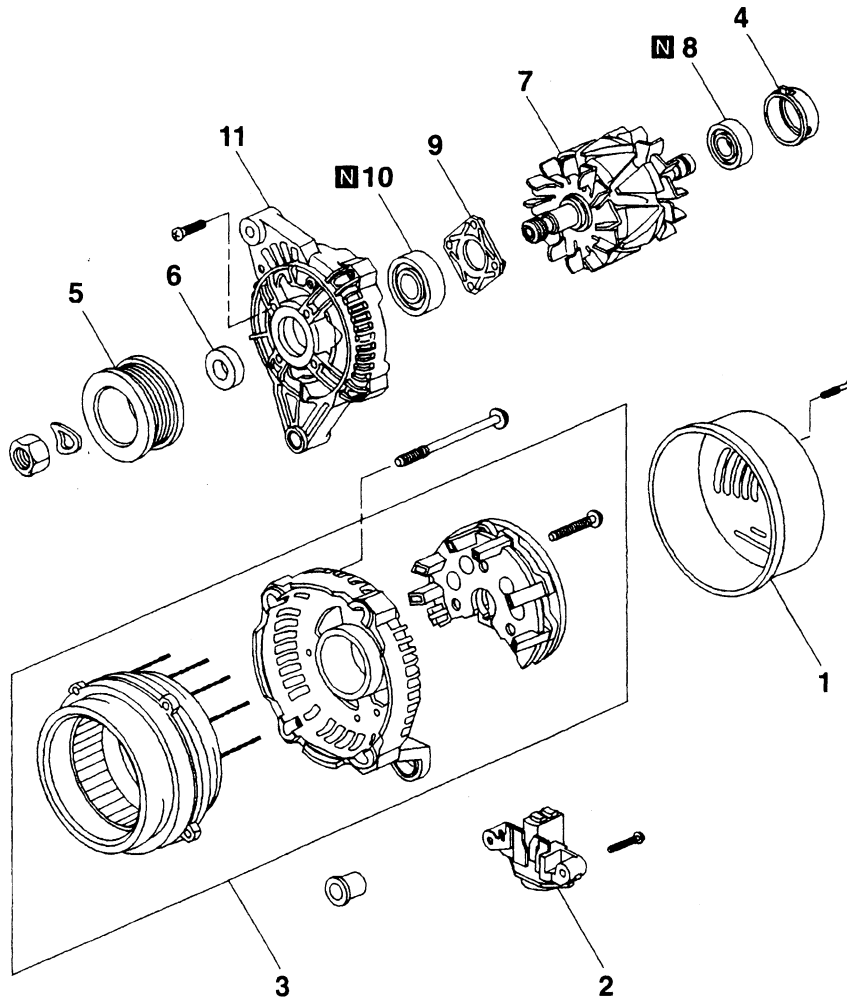

9EN0598

Disassembly steps

1. Rear end cover
2. Brush holder assembly
3. Stator and rectifier assembly
4. Bearing cover
5. Alternator pulley
6. Space collar

7. Rotor assembly
8. Rear bearing
9. Bearing retainer
10. Front bearing
11. Front bracket

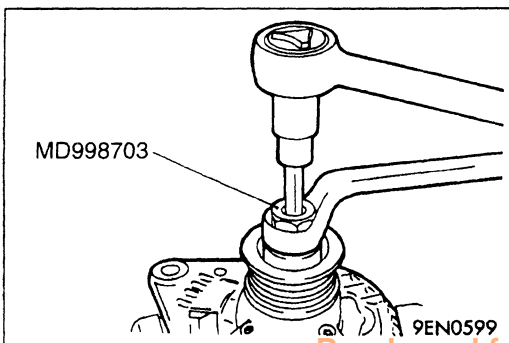

DISASSEMBLY SERVICE POINT

◀▶ ALTERNATOR PULLEY REMOVAL

1. Clamp the front bracket in a vise with soft jaws.
2. Use the special tool and a box wrench to hold the nut. Then attach a double hexagonal wrench to the rotor shaft and loosen the nut.

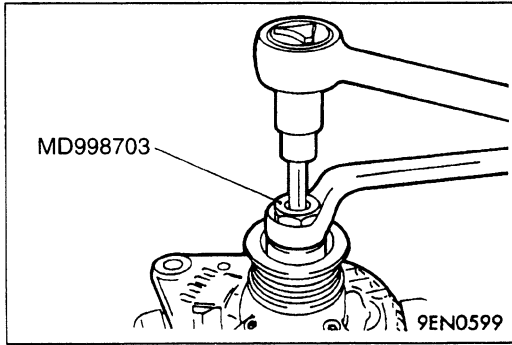

REASSEMBLY SERVICE POINT

▶◀ ALTERNATOR PULLEY INSTALLATION

1. Clamp the front bracket in a vise with soft jaws.
2. Use the special tool and a box wrench to hold the nut. Then attach a double hexagonal wrench to the rotor shaft and tighten the nut.

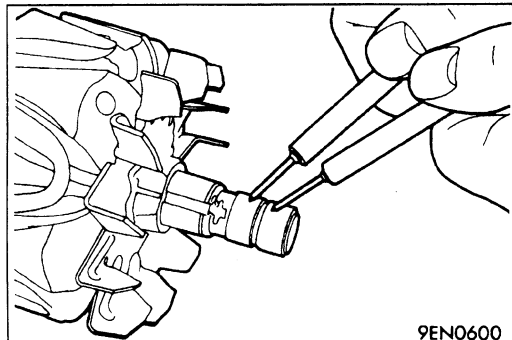

INSPECTION

16100170087

ROTOR

1. Check field coil for continuity. Check to ensure that there is continuity between slip rings. If resistance is extremely small, it means that there is a short. If there is no continuity or if there is short circuit, replace rotor assembly.

Resistance value: Approx. 2.6 Ω

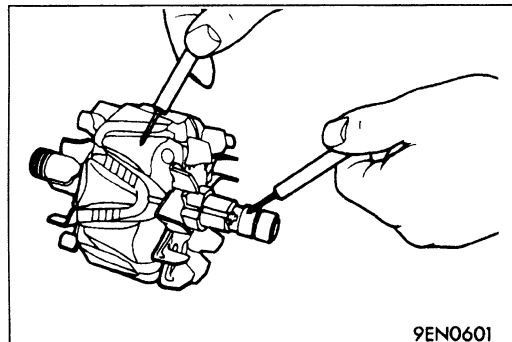

2. Check field coil for grounding. Check to ensure that there is no continuity between slip ring and core. If there is continuity, replace rotor assembly.

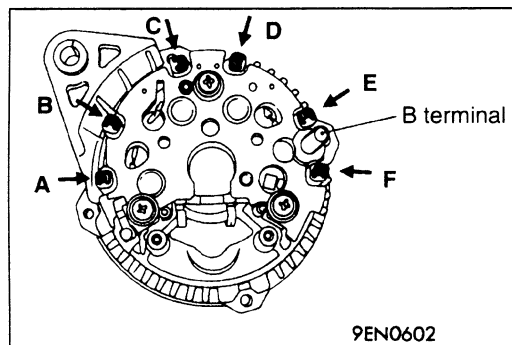

STATOR

1. Carry out a continuity test for the stator coil. Check that there is continuity between coil leads (A)–(B), (C)–(D) and (E)–(F). If there is no continuity, replace the stator and rectifier assembly.
2. Check the earth connection of the stator coil. Check that there is no continuity between each coil lead and the core. If there is continuity, replace the stator and rectifier assembly.

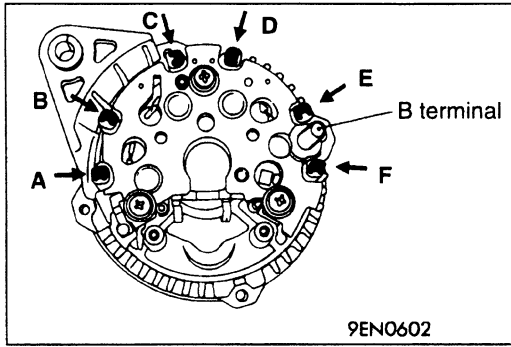

RECTIFIERS

1. Check the continuity between terminal (B) and coil leads (A), (C) and (E). If there is continuity in both directions, there is a short-circuit in the diode, so replace the stator and rectifier assembly.
2. Check the continuity between coil leads (B), (D) and (F) and the earth. If there is continuity in both directions, there is a short-circuit in the diode, so replace the stator and rectifier assembly.

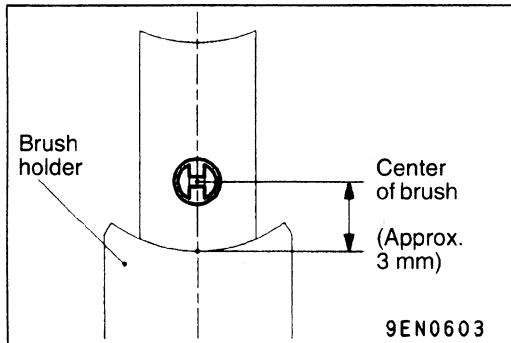

BRUSH

If the brush has been worn down to the centre of the mark (3 mm from the centre of the brush holder), replace the brush holder assembly.

STARTING SYSTEM

16200010030

GENERAL INFORMATION

If the ignition switch is turned to the "START" position, current flows in the coil provided inside magnetic switch, attracting the plunger. When the plunger is attracted, the lever connected to the plunger is actuated to engage the starter clutch. On the other hand, attracting the plunger will turn on the magnetic switch, allowing the B terminal and M terminal to conduct. Thus, current flows to

engage the starter motor.

When the ignition switch is returned to the "ON" position after starting the engine, the starter clutch is disengaged from the ring gear.

An overrunning clutch is provided between the pinion and the armature shaft, to prevent damage to the starter.

SYSTEM DIAGRAM

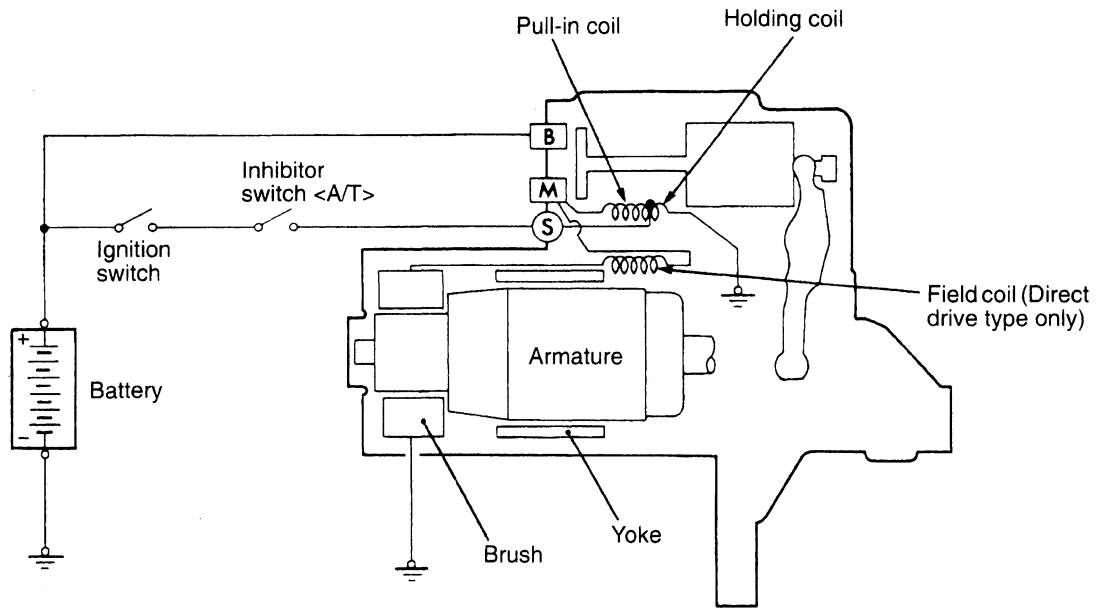

9EN0288

STARTER MOTOR SPECIFICATIONS

| Items | M/T | A/T |
|---------------------|-------------------------------------|--------------|
| Type | Reduction drive with planetary gear | Direct drive |
| Rated output kW/V | 0.9/12 | 0.9/12 |
| No. of pinion teeth | 8 | 8 |

SERVICE SPECIFICATIONS

16200030029

| Items | Standard value | Limit |
|--|----------------|-------|
| Pinion gap <Direct drive type> mm | 0.5–2.0 | – |
| Commutator outer diameter <Direct drive type> mm | 32.0 | 31.0 |
| Commutator runout <Direct drive type> mm | 0.05 | 0.1 |
| Commutator undercut <Direct drive type> mm | 0.5 | 0.2 |
| Brush length <Reduction drive type> mm | – | 11 |

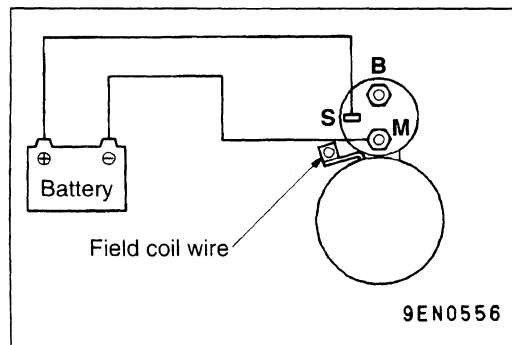
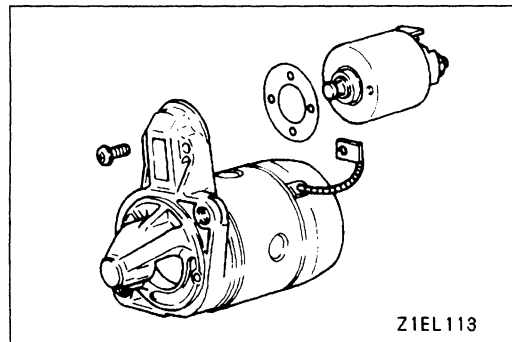
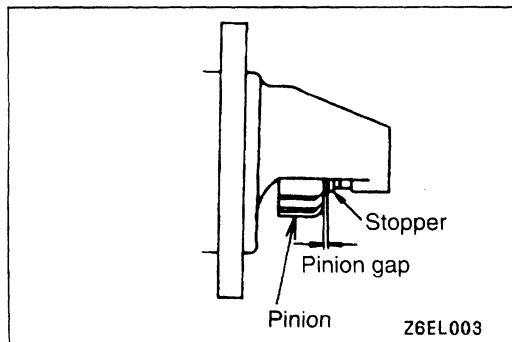
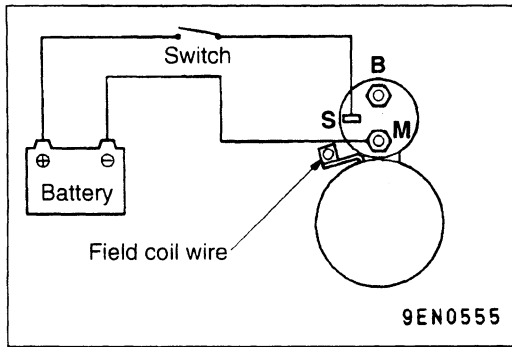

STARTER MOTOR

16200110020

INSPECTION

PINION GAP ADJUSTMENT <Direct drive type>

1. Disconnect field coil wire from M-terminal of magnetic switch.
2. Connect a 12V battery between S-terminal and M-terminal.
3. Set switch to "ON", and pinion will move out.

Caution

This test must be performed quickly (in less than 10 seconds) to prevent coil from burning.

4. Check pinion to stopper clearance (pinion gap) with a thickness gauge.

Pinion gap: 0.5–2.0 mm

5. If pinion gap is out of specification, adjust by adding or removing gaskets between magnetic switch and front bracket.

MAGNETIC SWITCH PULL-IN TEST

1. Disconnect field coil wire from M-terminal of magnetic switch.
2. Connect a 12V battery between S-terminal and M-terminal.

Caution

This test must be performed quickly (in less than 10 seconds) to prevent coil from burning.

3. If pinion moves out, then pull-in coil is good. If it doesn't, replace magnetic switch.

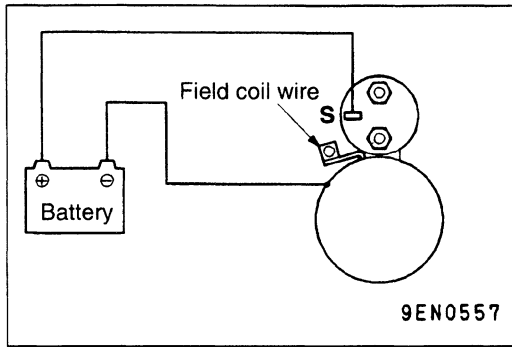

MAGNETIC SWITCH HOLD-IN TEST

1. Disconnect field coil wire from M-terminal of magnetic switch.
2. Connect a 12V battery between S-terminal and body.

Caution

This test must be performed quickly (in less than 10 seconds) to prevent coil from burning.

3. Manually pull out the pinion as far as the pinion stopper position.
4. If pinion remains out, everything is in order. If pinion moves in, hold-in circuit is open. Replace magnetic switch.

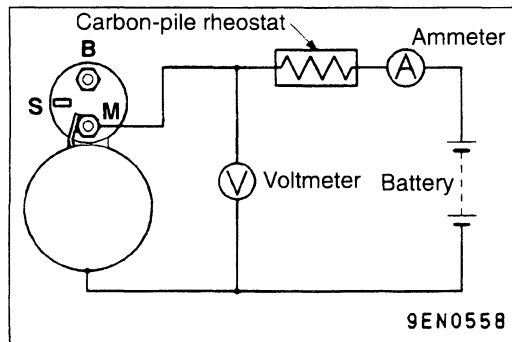

FREE RUNNING TEST

1. Place starter motor in a vise equipped with soft jaws and connect a fully-charged 12-volt battery to starter motor as follows:
2. Connect a test ammeter (100-ampere scale) and carbon pile rheostat in series with battery positive post and starter motor terminal.
3. Connect a voltmeter (15-volt scale) across starter motor.
4. Rotate carbon pile to full-resistance position.
5. Connect battery cable from battery negative post to starter motor body.
6. Adjust the rheostat until the battery voltage shown by the voltmeter is 11.5V.
7. Confirm that the maximum amperage is within the specifications and that the starter motor turns smoothly and freely.

Current: max. 60 Amps

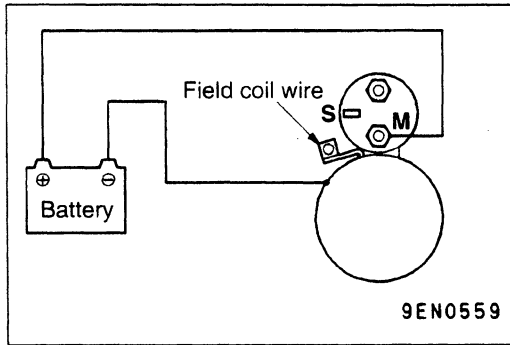

MAGNETIC SWITCH RETURN TEST

1. Disconnect field coil wire from M-terminal of magnetic switch.
2. Connect a 12V battery between M-terminal and body.

Caution

This test must be performed quickly (in less than 10 seconds) to prevent coil from burning.

3. Pull pinion out and release. If pinion quickly returns to its original position, everything is in order. If it doesn't, replace magnetic switch.

Caution

Be careful not to get your fingers caught when pulling out the pinion.

DISASSEMBLY AND REASSEMBLY <DIRECT DRIVE TYPE>

16200120085

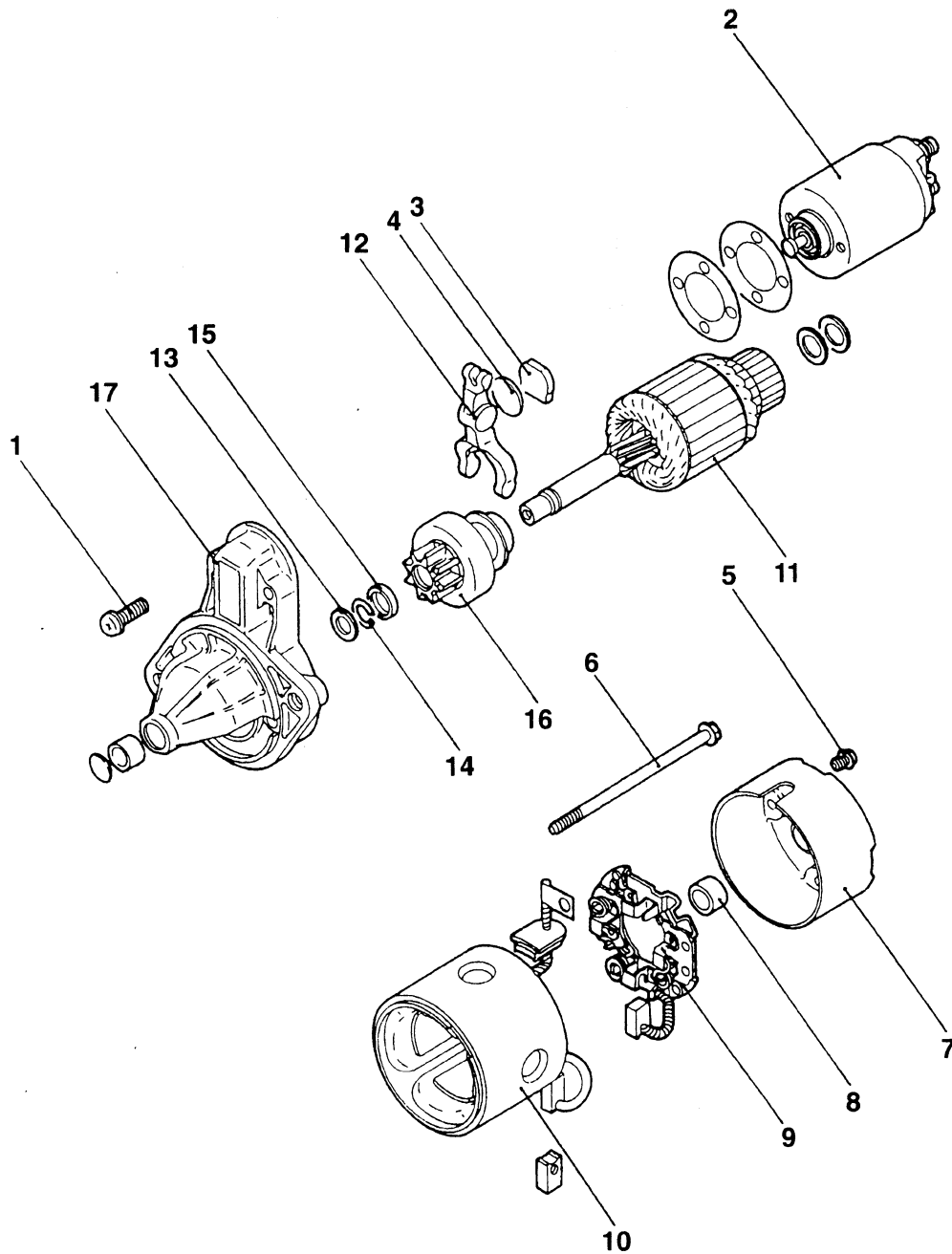

D9EN0186

Disassembly steps

1. Screw
2. Magnetic switch
3. Packing
4. Plate
5. Screw
6. Through bolt
7. Rear bracket
8. Rear bearing

9. Brush holder assembly
10. Yoke assembly
11. Armature
12. Lever
13. Washer
14. Snap ring
15. Stop ring
16. Overrunning clutch
17. Front bracket



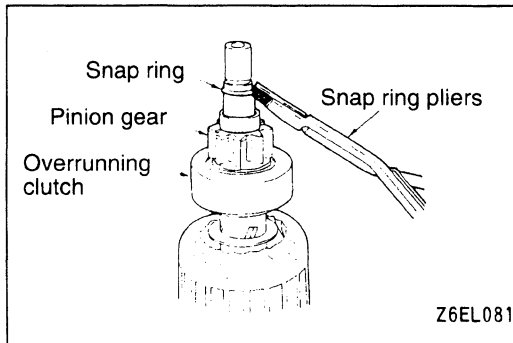
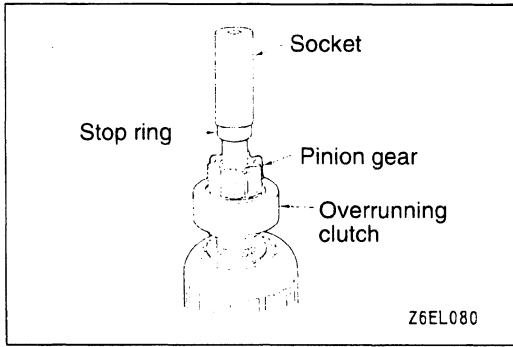

DISASSEMBLY SERVICE POINTS

◀▶ SNAP RING/STOP RING REMOVAL

1. Press stop ring off snap ring with a suitable socket.
2. Remove snap ring with snap ring pliers and then remove stop ring and overrunning clutch.

STARTER MOTOR PARTS CLEANING

1. Do not immerse parts in cleaning solvent. Immersing the yoke and field coil assembly and/or armature will damage insulation. Wipe these parts with a cloth only.
2. Do not immerse drive unit in cleaning solvent. Overrunning clutch is pre-lubricated at the factory and solvent will wash lubrication from clutch.
3. The drive unit may be cleaned with a brush moistened with cleaning solvent and wiped dry with a cloth.

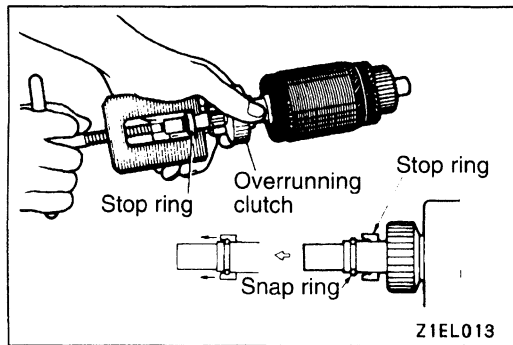

REASSEMBLY SERVICE POINTS

▶◀ STOP RING/SNAP RING INSTALLATION

Using a suitable pulling tool, pull overrunning clutch stop ring over snap ring.

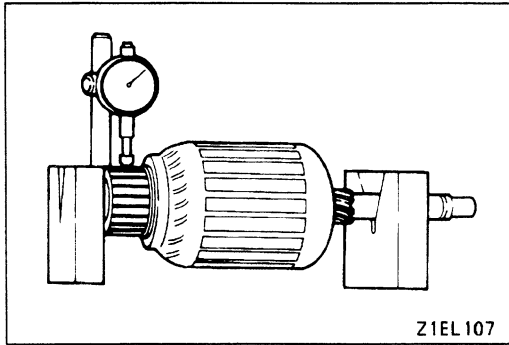

**INSPECTION
COMMUTATOR**

16200130088

1. Place the armature in a pair of "V" blocks and check the runout with a dial indicator.

Standard value: 0.05 mm

Limit: 0.1 mm

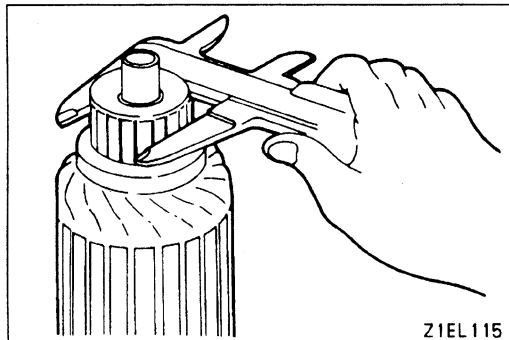

2. Measure the commutator outer diameter.

Standard value: 32.0 mm

Limit: 31.0 mm

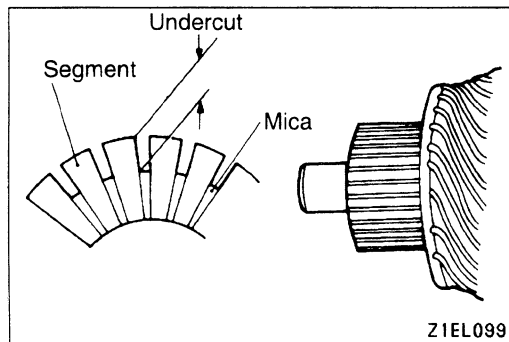

3. Check the undercut depth between segments.

Standard value: 0.5 mm

Limit: 0.2 mm

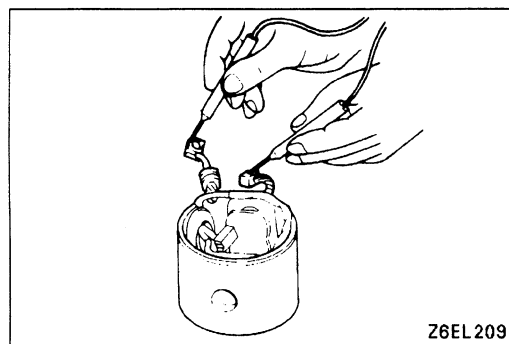

FIELD COIL OPEN-CIRCUIT TEST

Check the continuity between field brushes. If there is continuity, the field coil is in order.

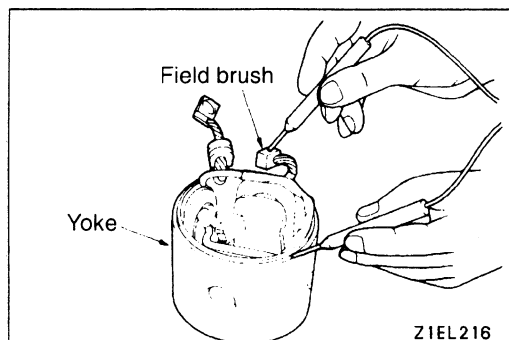

FIELD COIL GROUND TEST

Check the continuity between field coil brush and yoke. If there is no continuity, the field coil is free from earth.

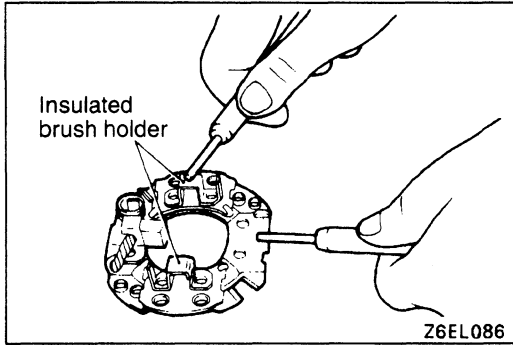

BRUSH HOLDER

Check the continuity between brush holder plate and brush holder.

If there is no continuity, the brush holder is in order.

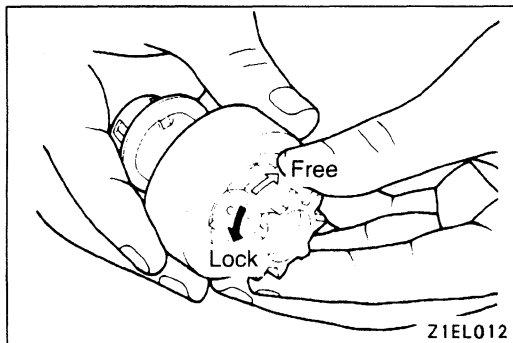

OVERRUNNING CLUTCH

1. While holding clutch housing, rotate the pinion. Drive pinion should rotate smoothly in one direction, but should not rotate in opposite direction. If clutch does not function properly, replace overrunning clutch assembly.
2. Inspect pinion for wear or burrs. If pinion is worn or burred, replace overrunning clutch assembly. If pinion is damaged, also inspect ring gear for wear or burrs.

FRONT AND REAR BRACKET BUSHING

Inspect bushing for wear or burrs. If bushing is worn or burred, replace front bracket assembly or rear bracket assembly.

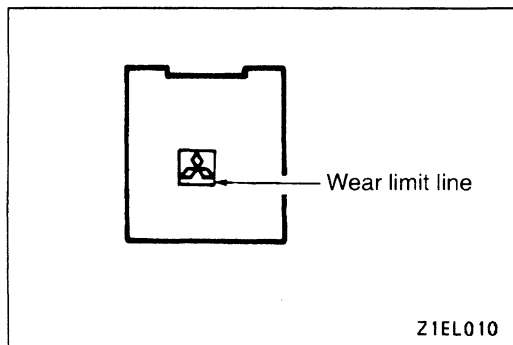

BRUSH AND SPRING REPLACEMENT

1. Brushes that are worn beyond wear limit line, or are oil-soaked, should be replaced.
2. When replacing field coil brushes, crush worn brush with pliers, taking care not to damage pigtail.

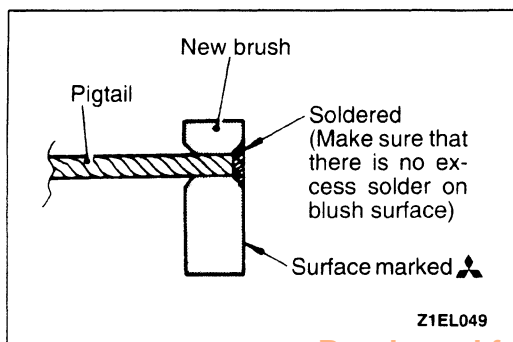

3. Sand pigtail end with sandpaper to ensure good soldering.
4. Insert pigtail into hole provided in new brush and solder it.
Make sure that pigtail and excess solder do not come out onto brush surface.
5. When replacing ground brush, slide the brush from brush holder by prying retainer spring back.

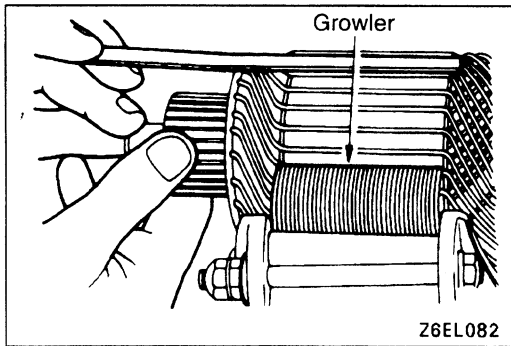

ARMATURE TEST

ARMATURE SHORT-CIRCUIT TEST

1. Place armature in a growler.
2. Hold a thin steel blade parallel and just above while rotating armature slowly in growler. A shorted armature will cause blade to vibrate and be attracted to the core. Replace shorted armature.

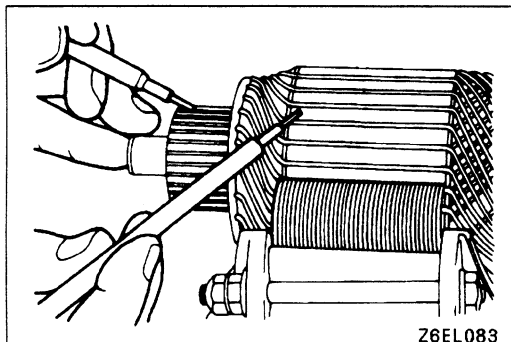

ARMATURE COIL EARTH TEST

Check the insulation between each commutator segment and armature coil core.
If there is no continuity, the insulation is in order.

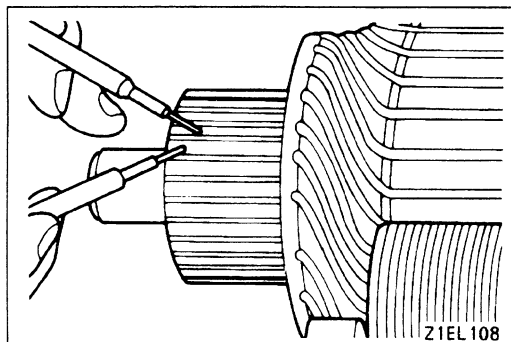

ARMATURE COIL OPEN-CIRCUIT INSPECTION

Check the continuity between segments. If there is continuity, the coil is in order.

DISASSEMBLY AND REASSEMBLY <REDUCTION DRIVE TYPE>

16200120115

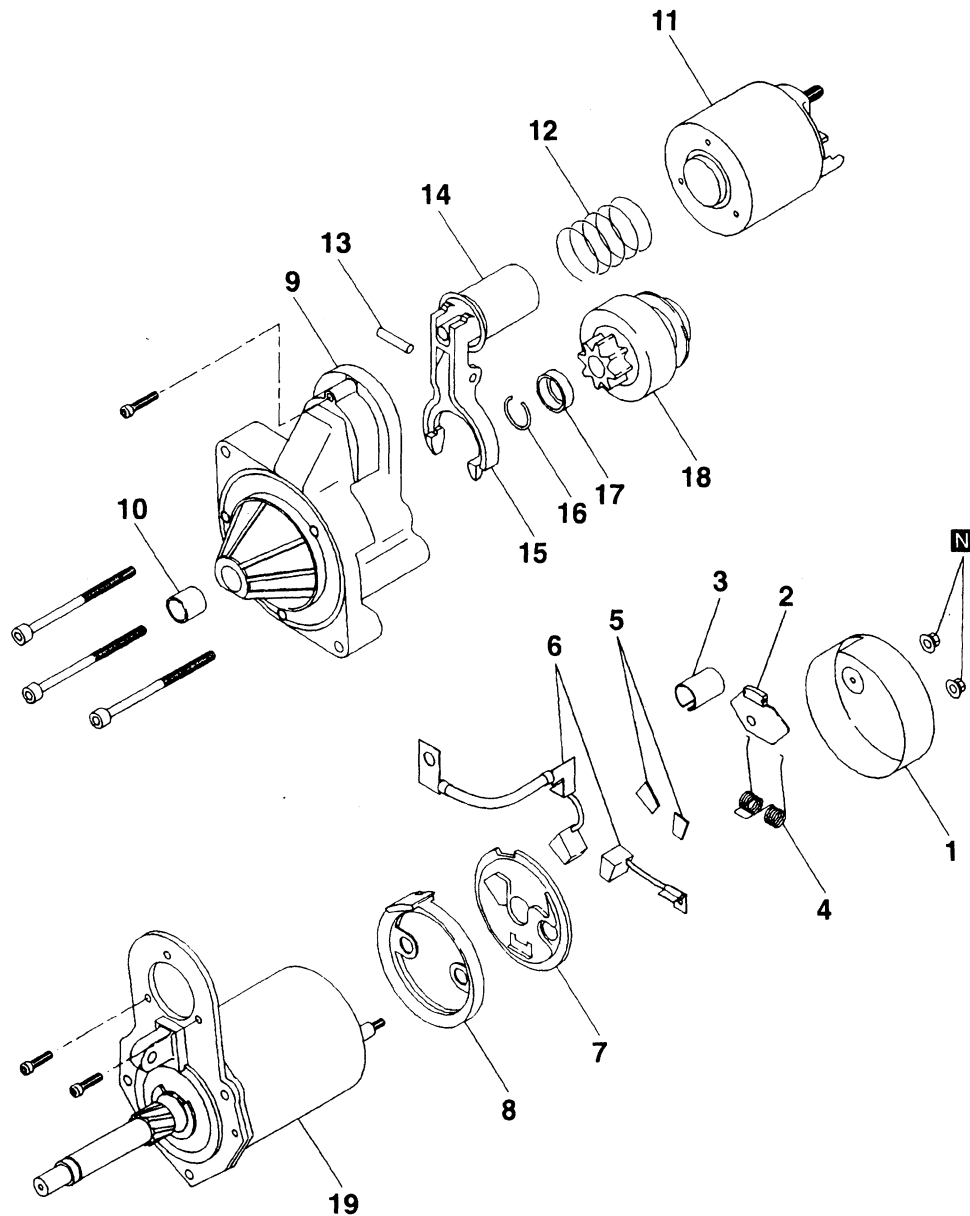

9EN0593

Disassembly steps

- | | |
|------------------|------------------------|
| 1. Rear cover | 11. Magnetic switch |
| 2. Rubber | 12. Spring |
| 3. Cover | 13. Pin |
| 4. Brush spring | 14. Plunger |
| 5. Plate | 15. Lever |
| 6. Brush | 16. Snap ring |
| 7. Brush holder | 17. Stop ring |
| 8. Packing | 18. Overrunning clutch |
| 9. Front bracket | 19. Motor assembly |
| 10. Bushing | |



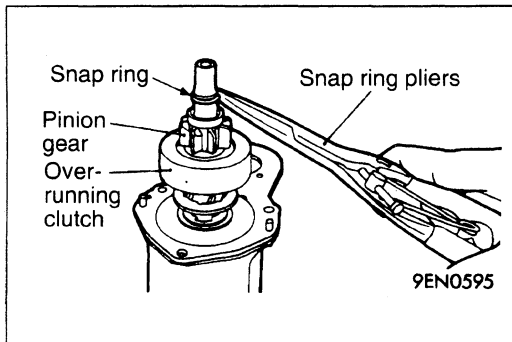
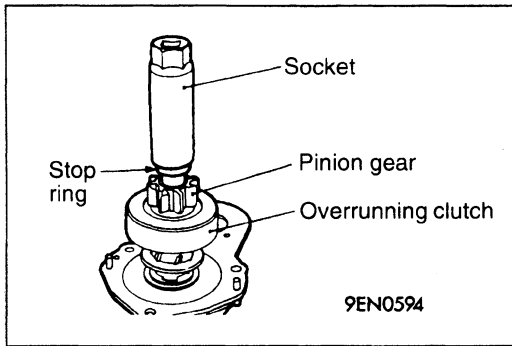

DISASSEMBLY SERVICE POINTS

◀▶ SNAP RING/STOP RING REMOVAL

1. Press stop ring off snap ring with a suitable socket.
2. Remove snap ring with snap ring pliers and then remove stop ring and overrunning clutch.

STARTER MOTOR PARTS CLEANING

1. Do not immerse parts in cleaning solvent. Immersing the motor assembly will damage insulation. Wipe motor assembly with a cloth only.
2. Do not immerse drive unit in cleaning solvent. Overrunning clutch is pre-lubricated at the factory and solvent will wash lubrication from clutch.
3. The drive unit may be cleaned with a brush moistened with cleaning solvent and wiped dry with a cloth.

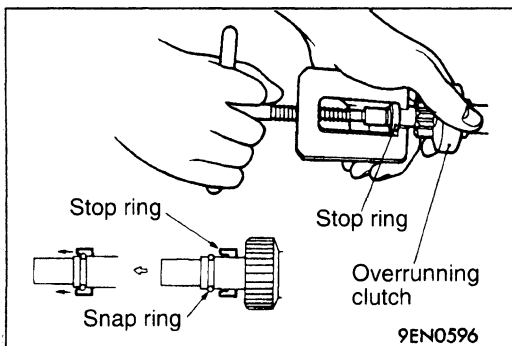

REASSEMBLY SERVICE POINTS

▶◀ STOP RING/SNAP RING INSTALLATION

Using a suitable pulling tool, pull overrunning clutch stop ring over snap ring.

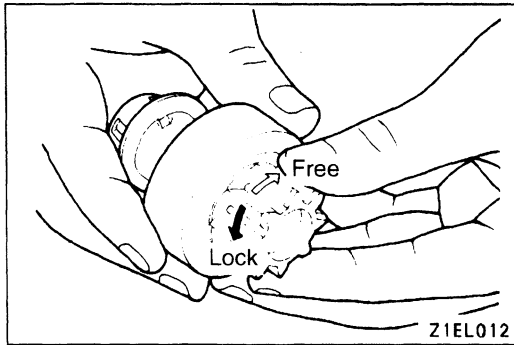

INSPECTION

16200130118

OVERRUNNING CLUTCH

1. While holding clutch housing, rotate the pinion. Drive pinion should rotate smoothly in one direction, but should not rotate in opposite direction. If clutch does not function properly, replace overrunning clutch assembly.
2. Inspect pinion for wear or burrs. If pinion is worn or burred, replace overrunning clutch assembly. If pinion is damaged, also inspect ring gear for wear or burrs.

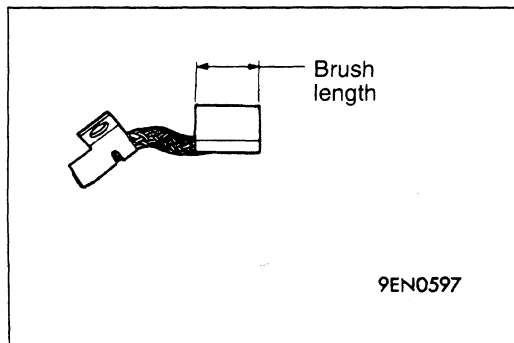

BRUSH

1. Check the brush length.

Limit: 11 mm

IGNITION SYSTEM

16300010033

GENERAL INFORMATION

<SOHC>

Interruption of the primary current flowing in the primary side of the ignition coil generates high voltage in the secondary side of the ignition coil. The high voltage thus generated is directed by the distributor to the applicable spark plug. The engine firing order is 1-3-4-2 cylinders.

On application of high voltage, the spark plug generates a spark to ignite the compressed air fuel mixture in the combustion chamber.

The engine ECU makes and breaks the primary current of the ignition coil to regulate the ignition timing.

The engine ECU detects the crankshaft position

by the crankshaft position sensor incorporated in the distributor to provide ignition at the most appropriate timing for the engine operating condition.

When the engine is cold or operated at a high altitude, the ignition timing is slightly advanced to provide optimum performance to the operating condition.

Furthermore, if knocking occurs, the ignition timing is gradually retarded until knocking ceases.

When the automatic transmission shifts gears, the ignition timing is also retarded in order to reduce output torque, thereby alleviating shifting shocks.

SYSTEM DIAGRAM

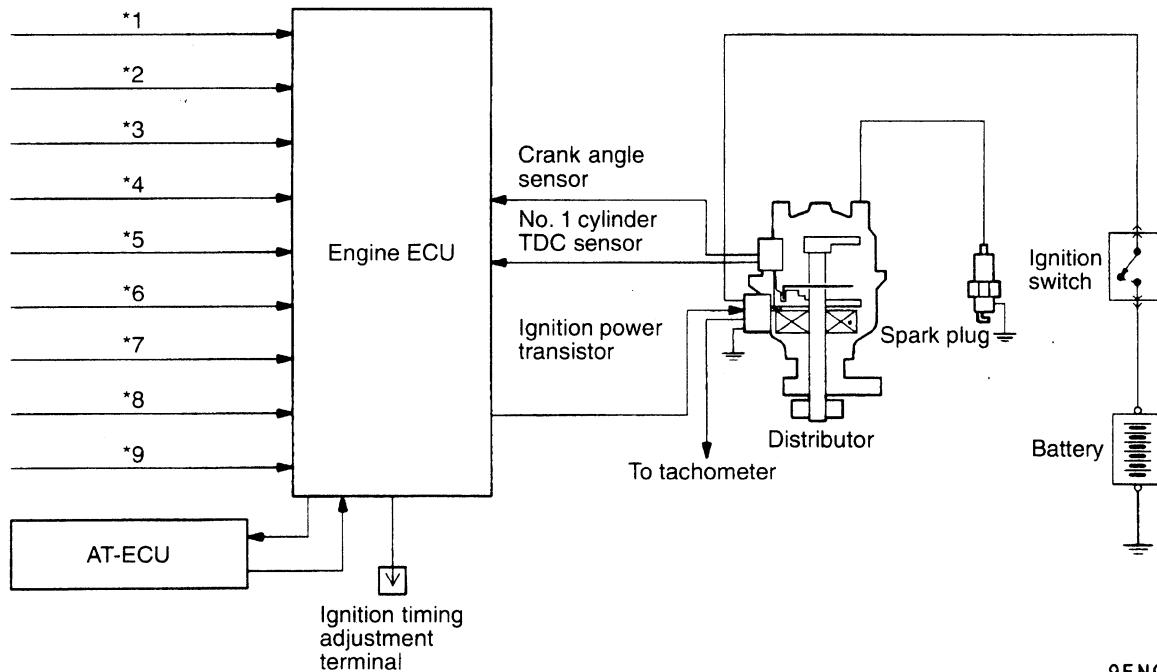

9EN0553

- *1: Air flow sensor
- *2: Barometric pressure sensor
- *3: Intake air temperature sensor
- *4: Engine coolant temperature sensor
- *5: Idle position switch

- *6: Detonation sensor
- *7: Vehicle speed sensor
- *8: Inhibitor switch
- *9: Ignition switch-ST

<DOHC>

This system is equipped with two ignition coils (A and B) with built-in power transistors for the No. 1 and No. 4 cylinders and the No. 2 and No. 3 cylinders respectively.

Interruption of the primary current flowing in the primary side of ignition coil A generates a high voltage in the secondary side of ignition coil A.

The high voltage thus generated is applied to the spark plugs of No. 1 and No. 4 cylinders to generate sparks. At the time that the sparks are generated at both spark plugs, if one cylinder is at the compression stroke, the other cylinder is at the exhaust stroke, so that ignition of the compressed air/fuel mixture occurs only for the cylinder which is at the compression stroke.

In the same way, when the primary current flowing in ignition coil B is interrupted, the high voltage thus generated is applied to the spark plugs of No. 2 and No. 3 cylinders.

The engine-ECU turns the two power transistors inside the ignition coils alternately on and off. This causes the primary currents in the ignition coils to be alternately interrupted and allowed to flow to fire the cylinders in the order 1-3-4-2.

The engine ECU determines which ignition coil should be controlled by means of the signals from the camshaft position sensor which is incorporated in the camshaft and from the crankshaft position sensor which is incorporated in the crankshaft. It also detects the crankshaft position in order to provide ignition at the most appropriate timing in response to the engine operation conditions.

When the engine is cold or operated at high altitudes, the ignition timing is slightly advanced to provide optimum performance.

Furthermore, if knocking occurs, the ignition timing is gradually retarded until knocking ceases.

SYSTEM DIAGRAM

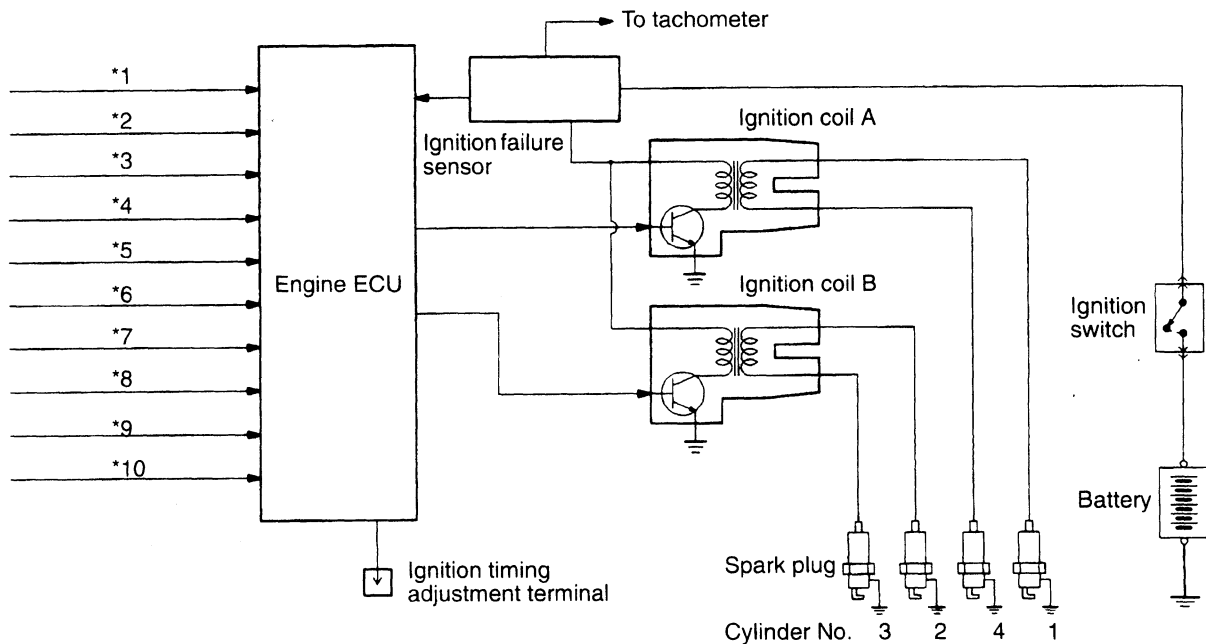

9EN0554

- *1: Air flow sensor
- *2: Barometric pressure sensor
- *3: Intake air temperature sensor
- *4: Engine coolant temperature sensor
- *5: Idle position switch

- *6: Camshaft position sensor
- *7: Crank angle sensor
- *8: Ignition switch-ST
- *9: Detonation sensor
- *10: Vehicle speed sensor

DISTRIBUTOR SPECIFICATIONS

| | |
|-------------------|---|
| Items | SOHC |
| Type | Contact pointless with built-in ignition coil |
| Advance mechanism | Electronic |
| Firing order | 1-3-4-2 |

IGNITION COIL SPECIFICATIONS

| | | |
|-------|--|---------------|
| Items | SOHC | DOHC |
| Type | Molded single-coil with a built-in distributor | Molded 2-coil |

SPARK PLUG SPECIFICATIONS

| | |
|--------------|------------|
| Items | SOHC, DOHC |
| NGK | BKR6E-11 |
| NIPPON DENSO | K20PR-U11 |
| BOSCH | FR7DC |
| CHAMPION | RC9YC4 |

SERVICE SPECIFICATIONS

16300030039

IGNITION COIL

| | | |
|-------------------------------------|---------|-------|
| Items | SOHC | DOHC |
| Primary coil resistance Ω | 0.5-0.7 | - |
| Secondary coil resistance $k\Omega$ | 21-30 | 17-25 |

IGNITION FAILURE SENSOR

| | |
|---------------------|-------------|
| Items | DOHC |
| Resistance Ω | 0.1 or less |

SPARK PLUG

| | |
|-------------------|------------|
| Items | SOHC, DOHC |
| Spark plug gap mm | 1.0-1.1 |

RESISTIVE CORD

| | |
|----------------------|------------|
| Items | SOHC, DOHC |
| Resistance $k\Omega$ | max. 22 |

SPECIAL TOOL

16300060038

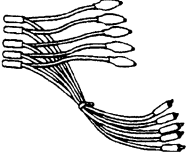
| Tool | Number | Name | Use |
|---|----------|------------------|--|
|  | MB991348 | Test harness set | Inspection of ignition primary voltage (power transistor connection) |

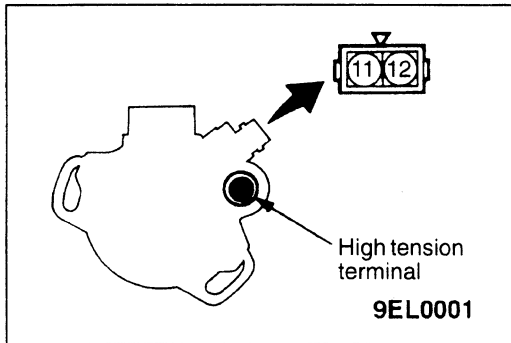

ON-VEHICLE SERVICE

16300120040

IGNITION COIL CHECK

<SOHC>

1. Measurement of the primary coil resistance
 Measure the resistance between connector terminal 11 and 12 of the distributor.
Standard value: 0.5–0.7 Ω
2. Measurement of secondary coil resistance
 Measure the resistance between the high-voltage terminals and connector terminals 11 or 12.
Standard value: 21–30 kΩ

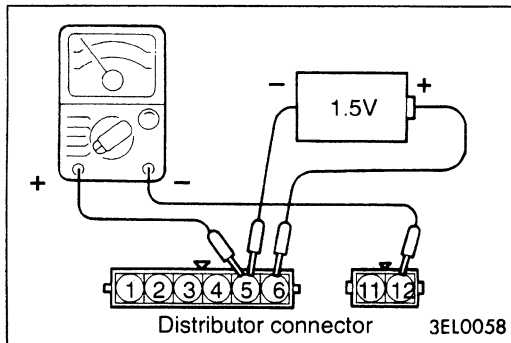

POWER TRANSISTOR CONTINUITY CHECK

16300130043

<SOHC>

NOTE
 An analog-type circuit tester should be used.

| Voltage: 1.5V | Terminal No. | | |
|-----------------------------|--------------|-------|-------|
| | 5 | 6 | 12 |
| When current is flowing | ⊖ — ⊕ | ⊖ — ⊕ | ⊖ — ⊕ |
| When current is not flowing | ○ — ○ | ○ — ○ | ○ — ○ |

Replace the power transistor if there is a malfunction.

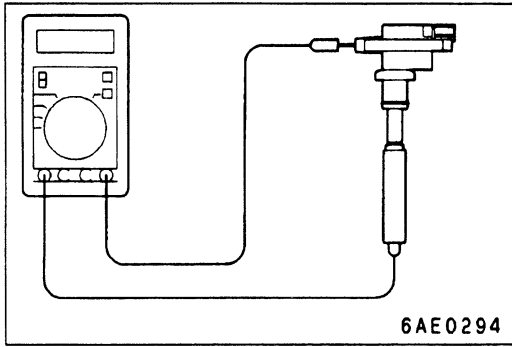

IGNITION COIL (WITH BUILT-IN POWER TRANSISTOR) CHECK

16300120057

<DOHC>

Check by the following procedure, and replace if there is a malfunction.

SECONDARY COIL RESISTANCE CHECK

Measure the resistance between the high-voltage terminals of the ignition coil.

Standard value: 17–25 k Ω

PRIMARY COIL AND POWER TRANSISTOR CONTINUITY CHECK

NOTE

An analog-type circuit tester should be used.

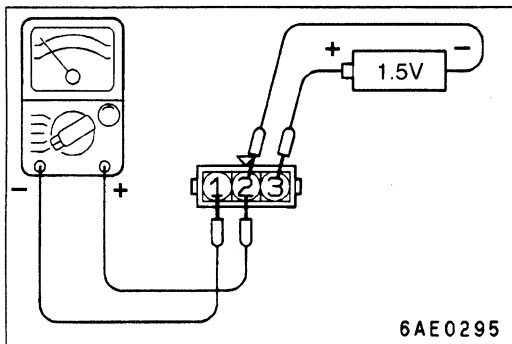

| Voltage: 1.5V | Terminal No. | | |
|-----------------------------|--------------|---|---|
| | 1 | 2 | 3 |
| When current is flowing | ○ | ⊖ | ⊕ |
| When current is not flowing | ○ | ○ | |

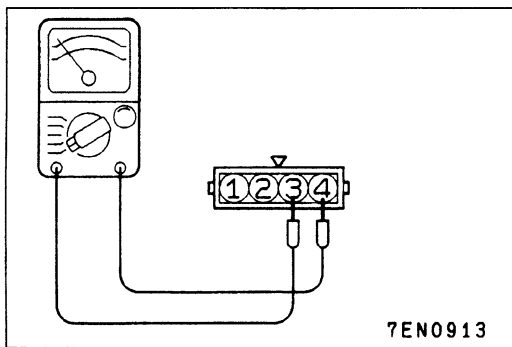

IGNITION FAILURE SENSOR CHECK <DOHC>

16300300017

NOTE

An analog-type circuit tester should be used.

Check that the resistance between terminals 3 and 4 is at the standard value.

Standard value: 0.1 Ω or less

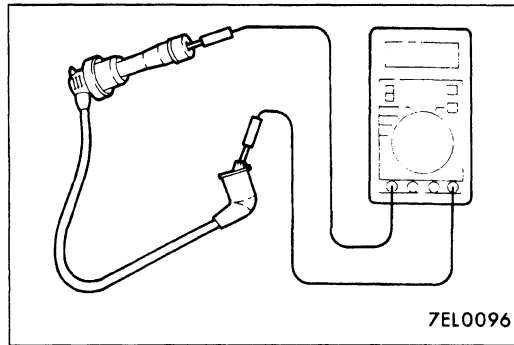

RESISTIVE CORD CHECK

16300140039

Measure the resistance of the all spark plug cables.

1. Check cap and coating for cracks.
2. Measure resistance.

Limit: Max. 22 kΩ

DETONATION SENSOR CHECK

16300180031

Check the detonation sensor circuit if self-diagnosis code, No. 31 is shown.

NOTE

For information concerning the self-diagnosis codes, after to GROUP 13A – Troubleshooting.

SPARK PLUG CHECK AND CLEANING

16300150056

1. Remove the spark plug cables.

Caution

When pulling off the spark plug cable from the plug always hold the cable cap, not the cable.

2. Remove the spark plugs.
3. Check for burned out electrode or damaged insulator. Check for even burning.
4. Remove carbon deposits with wire brush or plug cleaner. Remove sand from plug screw with compressed air.
5. Use a plug gap gauge to check that the plug gap is within the standard value range.

Standard value: 1.0–1.1 mm

If the plug gap is not within the standard value range, adjust by bending the earth electrode.

6. Clean the engine plug holes.

Caution

Be careful not to allow foreign matter in cylinders.

7. Install the spark plugs.

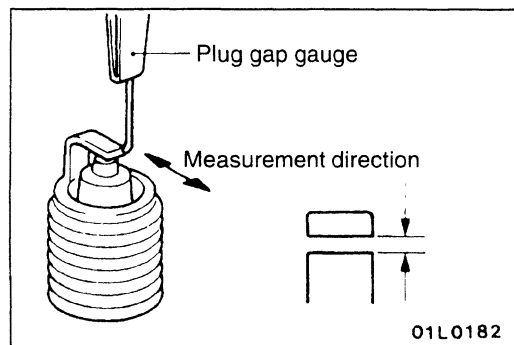

CRANK ANGLE SENSOR, TOP DEAD CENTER SENSOR <SOHC>, CAMSHAFT POSITION SENSOR, CRANKSHAFT POSITION SENSOR <DOHC> CHECK

16300260049

Refer to GROUP 13A – Troubleshooting.

WAVEFORM CHECK USING AN ANALYZER

16300170052

Ignition Secondary Voltage Check

<SOHC>

MEASUREMENT METHOD

1. Clamp the spark plug cable of the No. 1 cylinder with the secondary pickup and check the waveform.
2. Connect the secondary pickup to the other cylinders in turn and check the waveforms for each cylinder.

STANDARD WAVEFORM

Observation Conditions

| FUNCTION | SECONDARY |
|------------------|-----------------|
| PATTERN HEIGHT | HIGH (or LOW) |
| PATTERN SELECTOR | RASTER |
| Engine Speed | Curb idle speed |

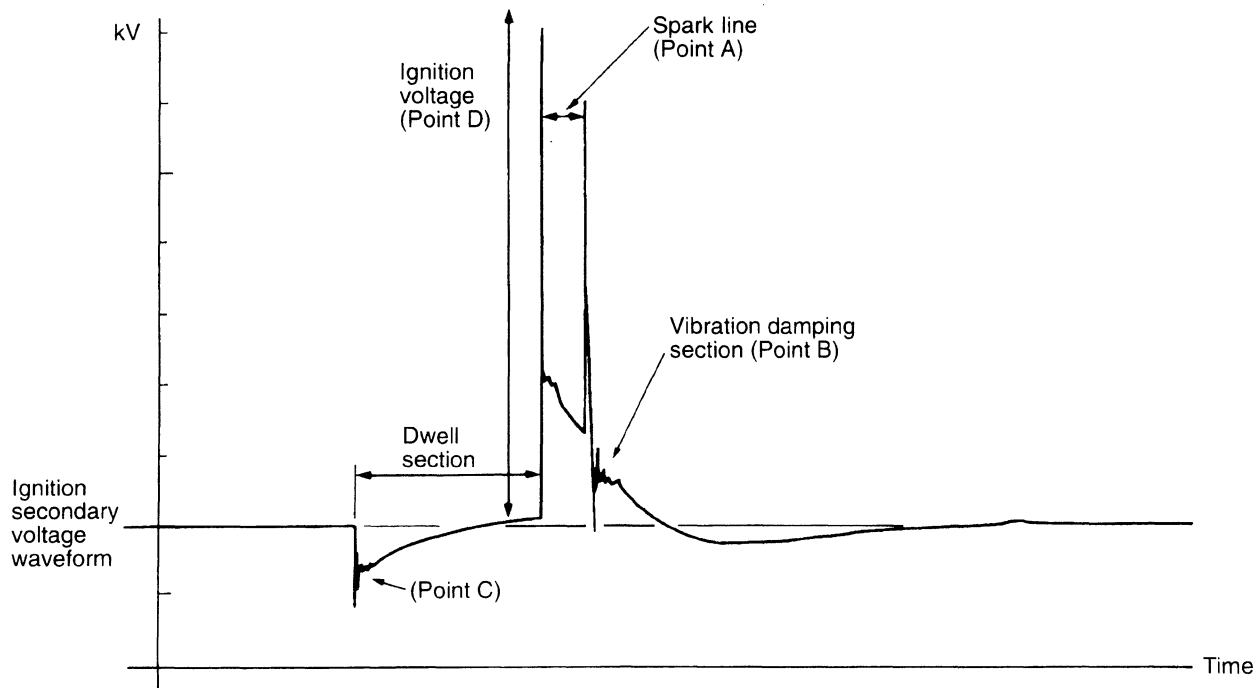

7EL0128

16-34

ENGINE ELECTRICAL – Ignition System

WAVEFORM OBSERVATION POINTS

Point A: The height, length and slope of the spark line show the following trends (Refer to abnormal waveform examples, 1, 2, 3 and 4).

| Spark line | Plug gap | Condition of electrode | Compression force | Concentration of air mixture | Ignition timing | Spark plug cable | |
|------------|----------|------------------------|-------------------|------------------------------|-----------------|------------------|-----------------|
| Length | Long | Small | Normal | Low | Rich | Advanced | Leak |
| | Short | Large | Large wear | High | Lean | Retarded | High resistance |
| Height | High | Large | Large wear | High | Lean | Retarded | High resistance |
| | Low | Small | Normal | Low | Rich | Advanced | Leak |
| Slope | Large | Plug is fouled | – | – | – | – | |

Point B: Number of vibration in reduction vibration section (Refer to abnormal waveform example 5)

| | |
|----------------------|--------------------|
| Number of vibrations | Coil and condenser |
| Three or more | Normal |
| Except above | Abnormal |

Point C: Number of vibrations at beginning of dwell section (Refer to abnormal waveform example 5)

| | |
|----------------------|----------|
| Number of vibrations | Coil |
| 5–6 or higher | Normal |
| Except above | Abnormal |

Point D: Ignition voltage height (distribution per each cylinder) shows the following trends.

| Ignition voltage | Plug gap | Condition of electrode | Compression force | Concentration of air mixture | Ignition timing | Spark plug cable |
|------------------|----------|------------------------|-------------------|------------------------------|-----------------|------------------|
| High | Large | Large wear | High | Lean | Retarded | High resistance |
| Low | Small | Normal | Low | Rich | Advanced | Leak |

EXAMPLES OF ABNORMAL WAVEFORMS

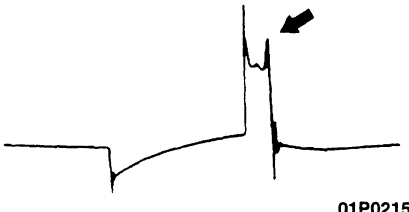
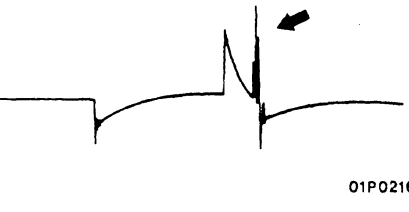
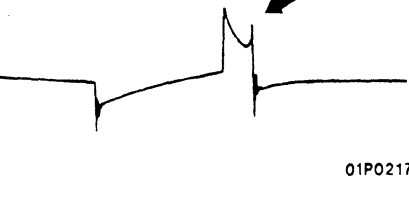
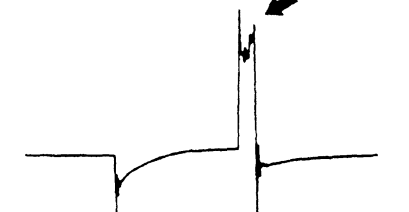
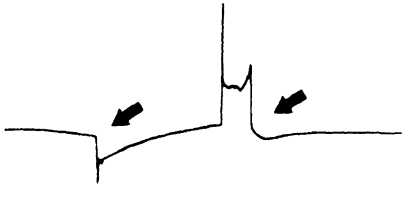
| Abnormal waveform | Wave characteristics | Cause of problem |
|---|---|--|
| <p>Example 1</p>  <p>01P0215</p> | <p>Spark line is high and short.</p> | <p>Spark plug gap is too large.</p> |
| <p>Example 2</p>  <p>01P0216</p> | <p>Spark line is low and long, and is sloping. Also, the second half of the spark line is distorted. This could be a result of misfiring.</p> | <p>Spark plug gap is too small.</p> |
| <p>Example 3</p>  <p>01P0217</p> | <p>Spark line is low and long, and is sloping. However, there is almost no spark line distortion.</p> | <p>Spark plug gap is fouled.</p> |
| <p>Example 4</p>  <p>01P0218</p> | <p>Spark line is high and short. Difficult to distinguish between this and abnormal waveform example 1.</p> | <p>Spark plug cable is nearly falling off. (Causing a dual ignition)</p> |
| <p>Example 5</p>  <p>01P0219</p> | <p>No waves in wave damping section.</p> | <p>Rare short in ignition coil.</p> |

<DOHC>

MEASUREMENT METHOD

1. Clamp the SECONDARY PICKUP around the spark plug cable.

NOTE

1. The peak ignition voltage will be reversed when the spark cables No. 2 and No. 4, or No. 1 and No. 3 cylinders are clamped.
 2. Because of the two-cylinder simultaneous ignition system, the waveforms for two cylinders in each group appear during waveform observation (No. 1 cylinder – No. 4 cylinder, No. 2 cylinder – No. 3 cylinder). However, waveform observation is only applicable for the cylinder with the spark plug cable clamped by the secondary pickup.
 3. Identifying which cylinder waveform is displayed can be difficult. For reference, remember that the waveform of the cylinder attached to the secondary pickup will be displayed as stable.
2. Clamp the spark plug cable with the trigger pickup.

NOTE

- Clamp the trigger pickup to the same spark plug cable clamped by the secondary pickup.

STANDARD WAVEFORM

Observation Conditions

| | |
|--------------------|-----------------|
| Function | Secondary |
| Pattern height | High (or Low) |
| Pattern selector | Raster |
| Engine revolutions | Curb idle speed |

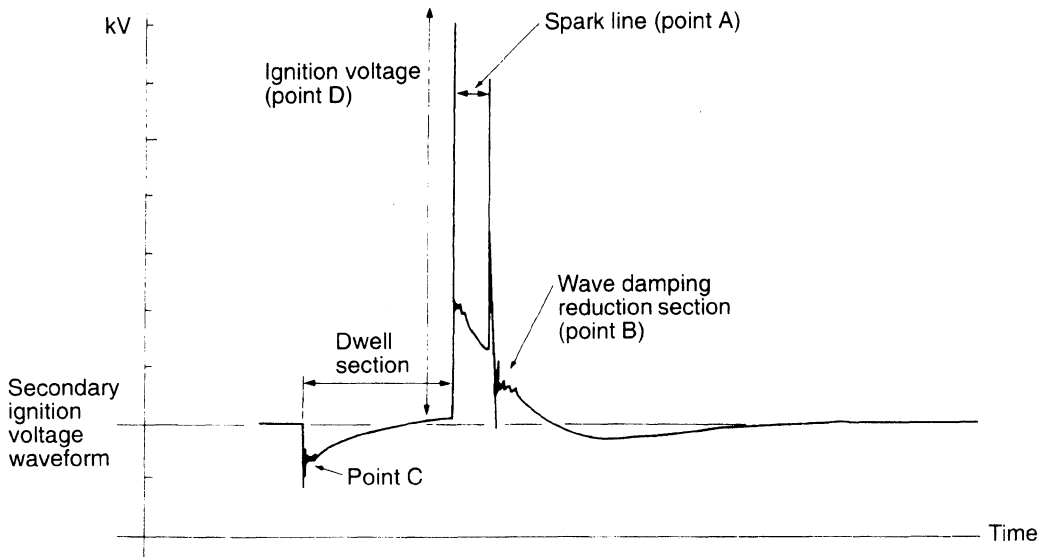

7EL0147

Observation Condition (The only change from above condition is the pattern selector.)

| | |
|------------------|---------|
| Pattern selector | Display |
|------------------|---------|

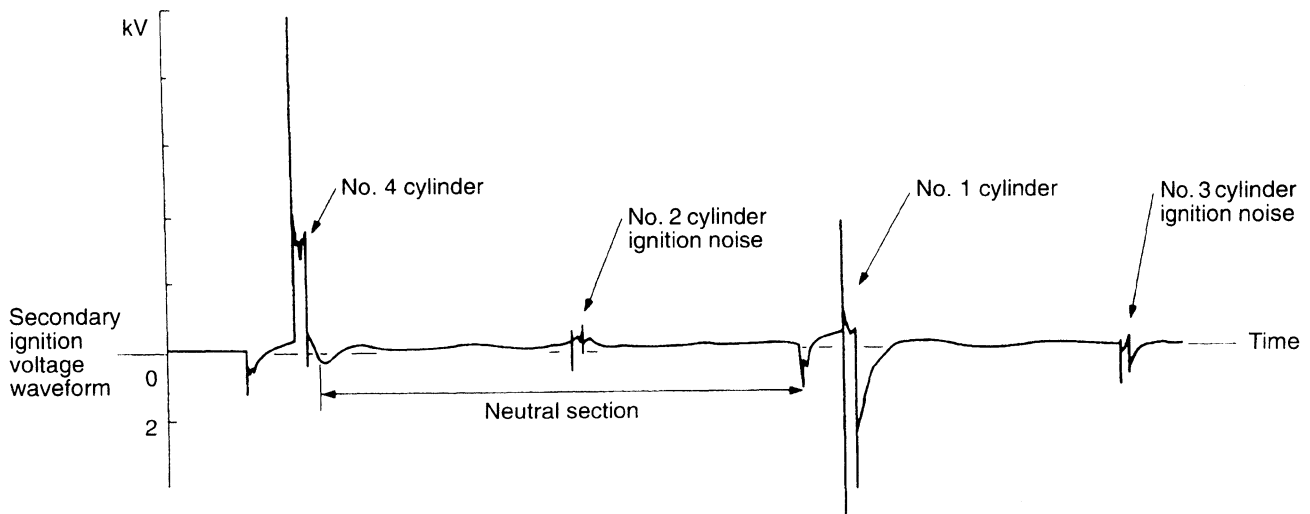

6EL0183

WAVEFORM OBSERVATION POINTS

For waveform observation points, refer to P.16-34.

EXAMPLES OF ABNORMAL WAVEFORMS

For examples of abnormal waveforms, refer to P.16-35.

Ignition Primary Voltage Waveform Check <SOHC>

MEASUREMENT METHOD

1. Disconnect the distributor 2 pin connector and connect the special tool (test harness: MB991348) in between. (All of the terminals should be connected.)

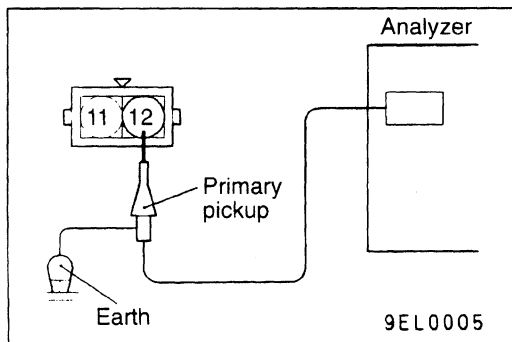

2. Connect the analyzer primary pickup to the distributor connector terminal 12.
3. Connect the primary pickup earth terminal.
4. Clamp the spark plug cable with the trigger pickup.

NOTE

The waveform of the cylinder clamped to the trigger pickup will appear at the left edge of the screen.

STANDARD WAVEFORM

Observation conditions

| FUNCTION | SECONDARY |
|------------------|-----------------|
| PATTERN HEIGHT | HIGH (or LOW) |
| PATTERN SELECTOR | RASTER |
| Engine Speed | Curb idle speed |

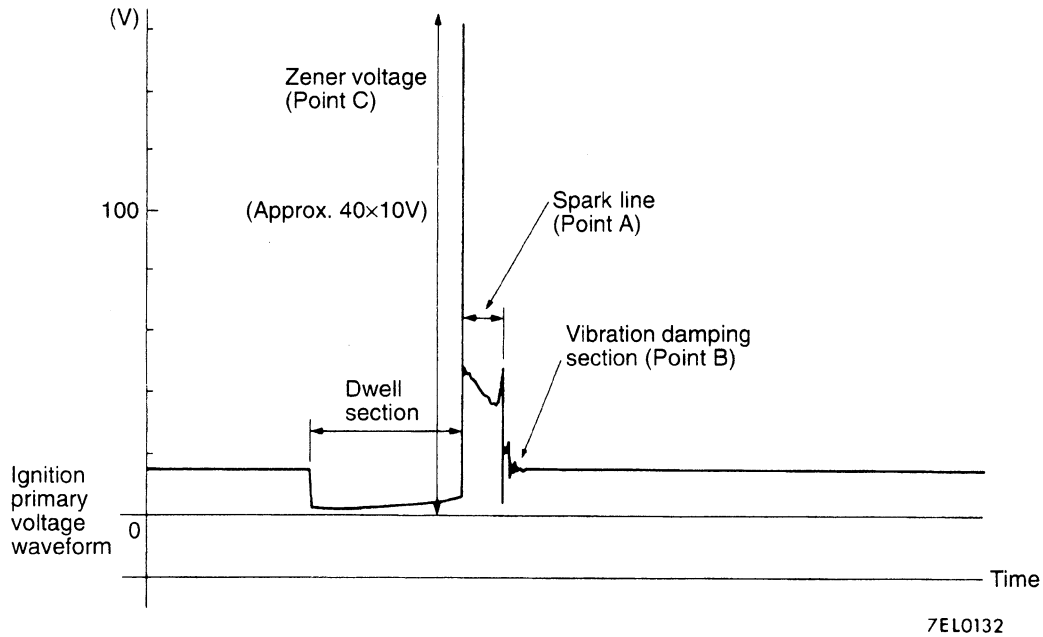

Observation conditions

(Only the pattern selector shown below changes from the previous conditions)

| PATTERN SELECTOR | DISPLAY |
|------------------|---------|
| | |

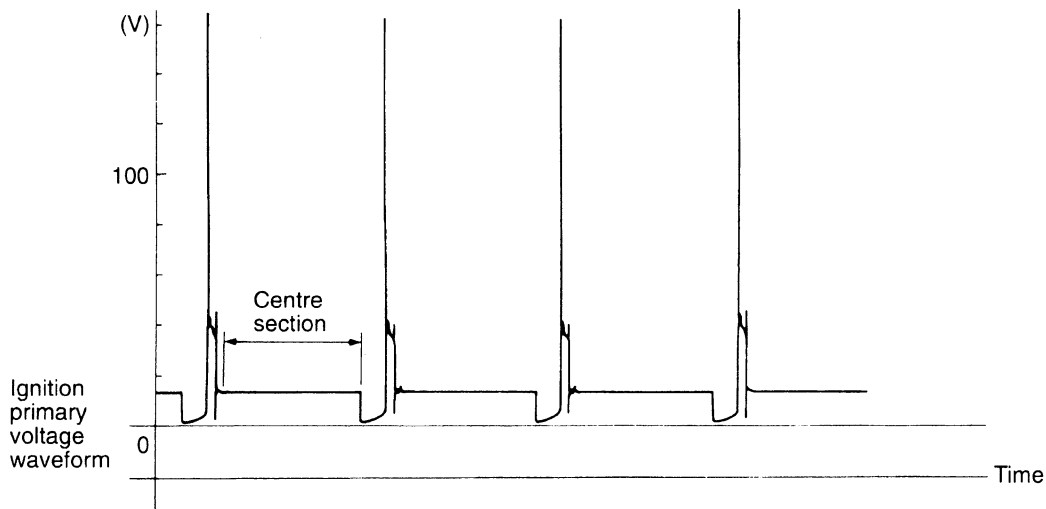

WAVEFORM OBSERVATION POINTS

Point A: The height, length and slope of the spark line (refer to abnormal waveform examples 1, 2, 3 and 4) show the following trends.

| Spark line | | Plug gap | Condition of electrode | Compression force | Concentration of air mixture | Ignition timing | High tension cable |
|------------|-------|----------|------------------------|-------------------|------------------------------|-----------------|--------------------|
| Length | Long | Small | Normal | Low | Rich | Advanced | Leak |
| | Short | Large | Large wear | High | Lean | Retarded | High resistance |
| Height | High | Large | Large wear | High | Lean | Retarded | High resistance |
| | Low | Small | Normal | Low | Rich | Advanced | Leak |
| Slope | | Large | Plug is fouled | – | – | – | – |



Point B: Number of vibration in reduction vibration section
(Refer to abnormal waveform example 5)

| | |
|----------------------|-----------------|
| Number of vibrations | Coil, condenser |
| 3 or higher | Except above |
| Normal | Abnormal |

Point C: Height of Zener voltage.

| | |
|-------------------------|---|
| Height of Zener voltage | Probable cause |
| High | Problem in Zener diode |
| Low | Abnormal resistance in primary coil circuit |

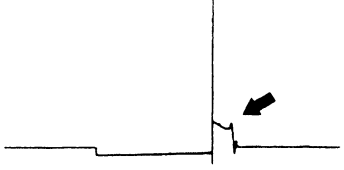
EXAMPLES OF ABNORMAL WAVEFORMS

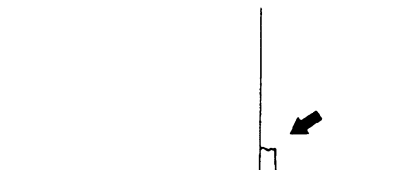
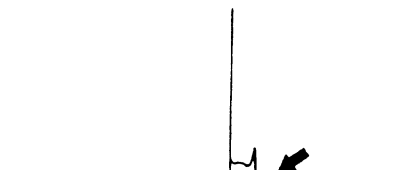
| Abnormal waveform | Wave characteristics | Cause of problem |
|---|--|---|
| <p>Example 1</p>  <p>01P0210</p> | Spark line is high and short. | Spark plug gap is too large. |
| <p>Example 2</p>  <p>01P0211</p> | Spark line is low and long, and is sloping. Also, the second half of the spark line is distorted. This could be a result of misfiring. | Spark plug gap is too small. |
| <p>Example 3</p>  <p>01P0212</p> | Spark line is low and long, and is sloping. However, there is almost no spark line distortion. | Spark plug gap is fouled. |
| <p>Example 4</p>  <p>01P0213</p> | Spark line is high and short. | Spark plug cable is nearly falling off. (Causing a dual ignition) |
| <p>Example 5</p>  <p>01P0214</p> | No waves in wave damping section | Rare short in ignition coil. |

DISTRIBUTOR <SOHC>

16300200034

REMOVAL AND INSTALLATION

Pre-removal and Post-installation Operation

- Engine Adjustment
(Refer to GROUP 11A – On-vehicle Service.)

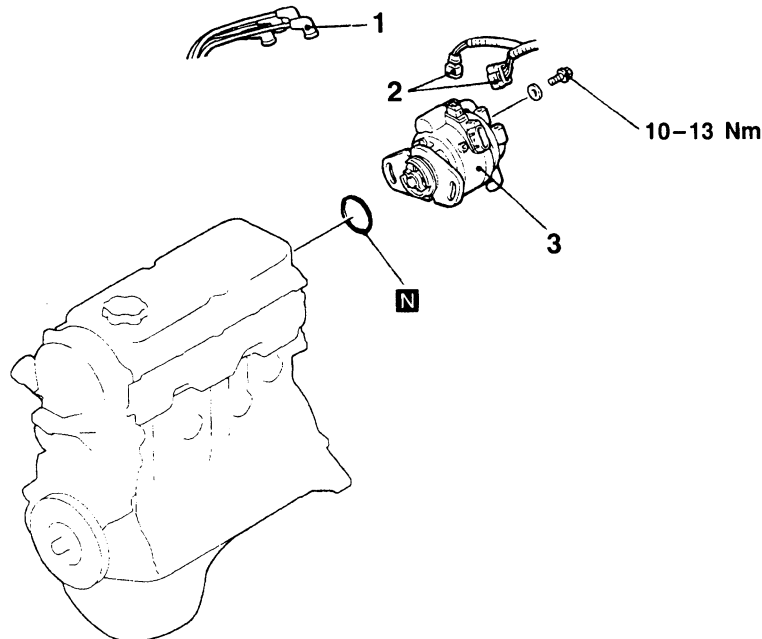

A16U0145

Removal steps

1. Spark plug cable connection
2. Distributor connector
3. Distributor

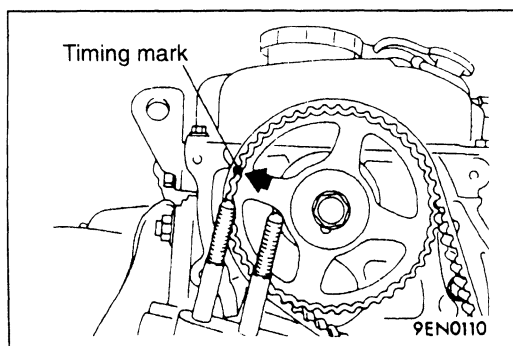

INSTALLATION SERVICE POINTS

►A◄ DISTRIBUTOR INSTALLATION

1. Remove the timing belt upper cover.
2. Turn the crankshaft clockwise to align the timing marks.

NOTE

The No. 1 cylinder will be at compression top dead centre if the timing mark on the camshaft sprocket is aligned with the timing mark on the cylinder head.

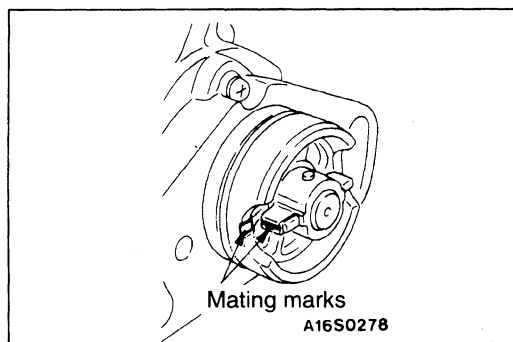

3. Align the mating mark on the distributor housing side with the mating mark on the coupling side. Install the distributor to the engine.

DISASSEMBLY AND REASSEMBLY

16300220047

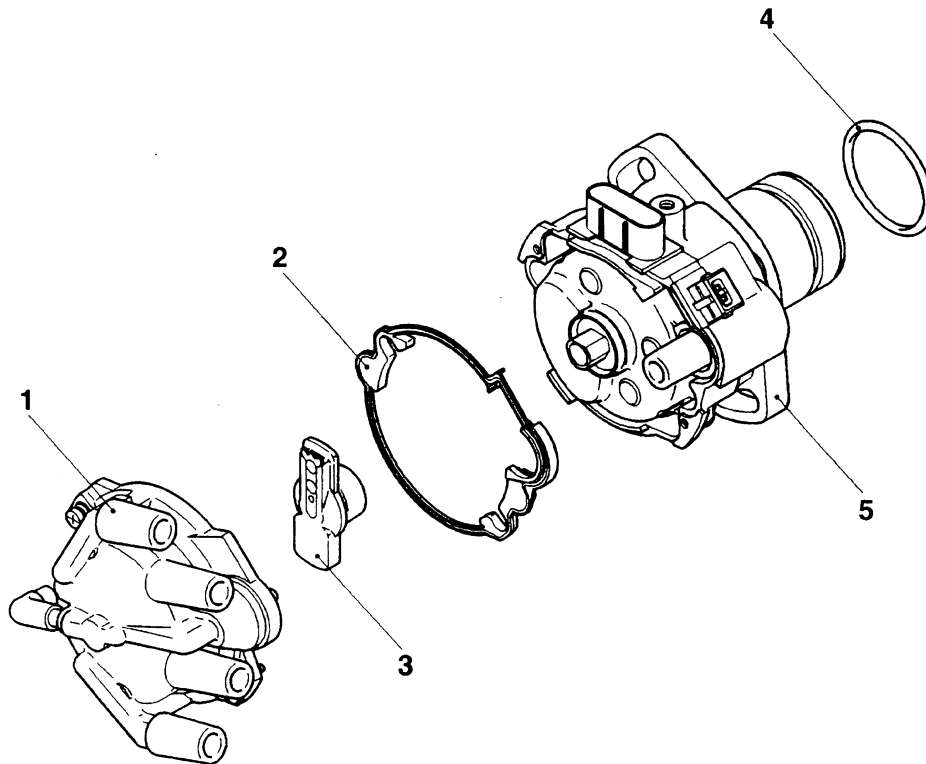

9EN0561

1. Distributor cap
2. Packing
3. Rotor
4. O-ring
5. Distributor housing

INSPECTION

16300230040

Check the following points; repair or replace if a problem is found.

CAP, MOTOR

1. There must be no cracking in the cap.
2. There must be no damage to the cap's electrode or the rotor's electrode.
3. Clean away any dirt from the cap and rotor.

IGNITION SYSTEM <DOHC>

16300320013

REMOVAL AND INSTALLATION

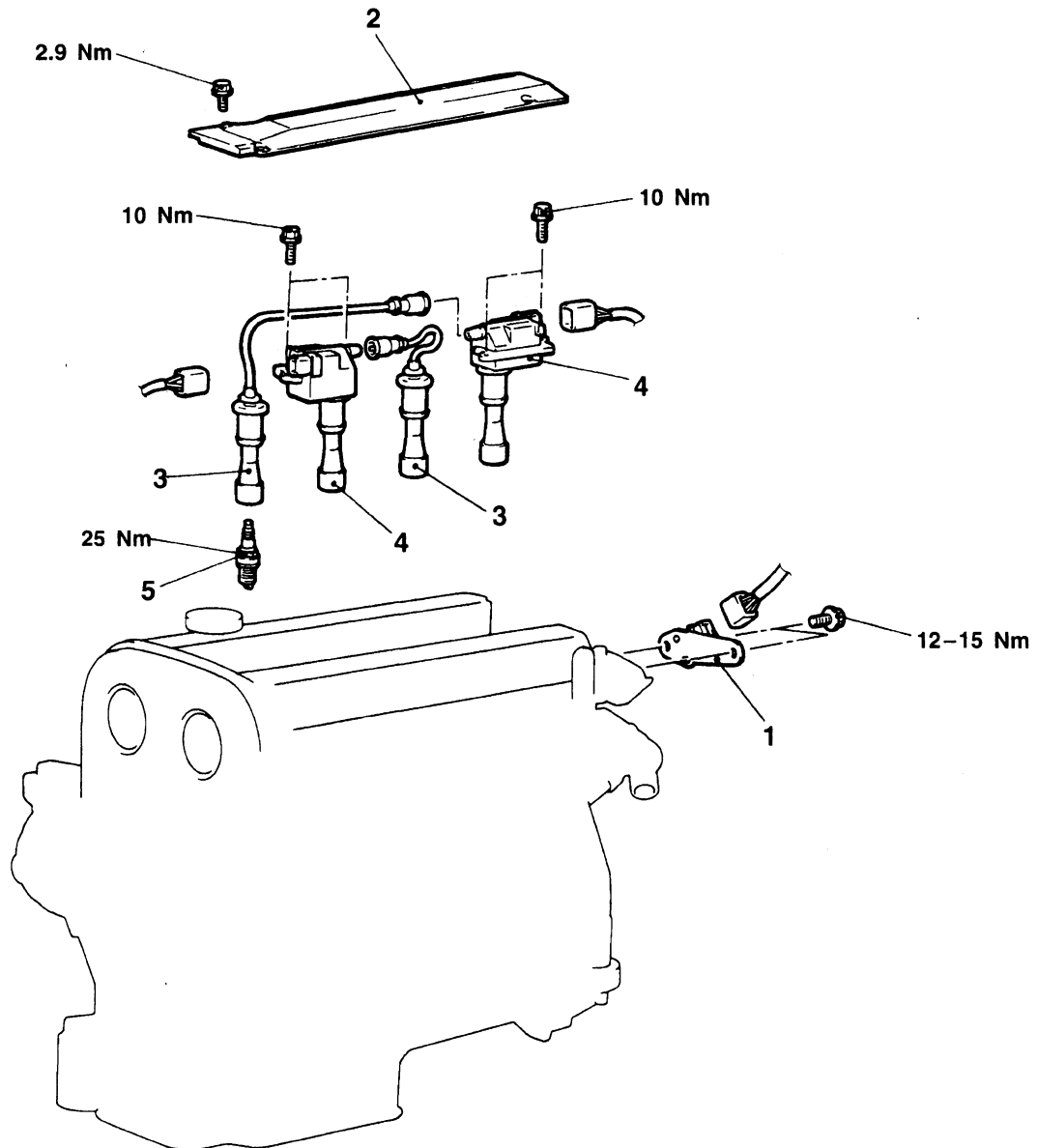

A16U0117

Removal steps

1. Ignition failure sensor
2. Center cover
3. Spark plug cable assembly
4. Ignition coil assembly
5. Spark plug

CAMSHAFT POSITION SENSOR AND CRANKSHAFT POSITION SENSOR <DOHC>

16300250039

REMOVAL AND INSTALLATION

Pre-removal and Post-installation Operation

- (1) Timing Belt Removal and Installation
(Refer to GROUP 11A.)
- (2) Exhaust Camshaft Sprocket Removal and Installation
(Refer to GROUP 11A – Camshaft and Camshaft Oil seal.)

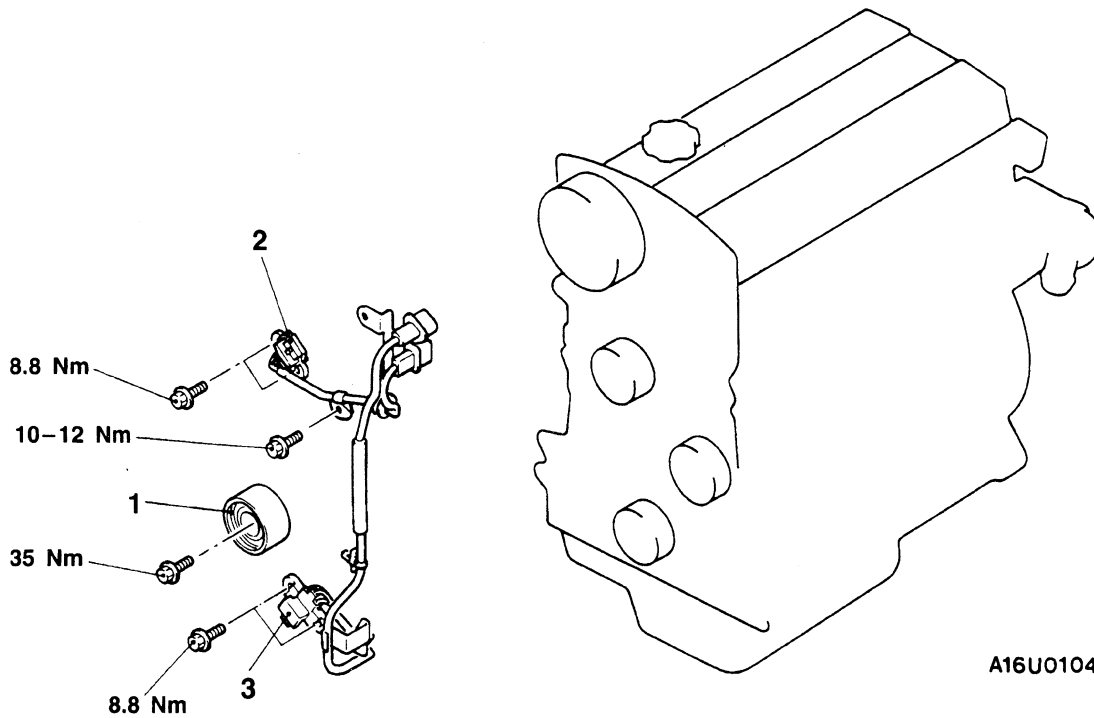

Removal steps

1. Idler pulley
2. Camshaft position sensor
3. Crankshaft position sensor

INSPECTION

16300260056

CAMSHAFT POSITION SENSOR, CRANKSHAFT POSITION SENSOR CHECK

Refer to GROUP 13A – Troubleshooting.

DETONATION SENSOR

16300280045

REMOVAL AND INSTALLATION

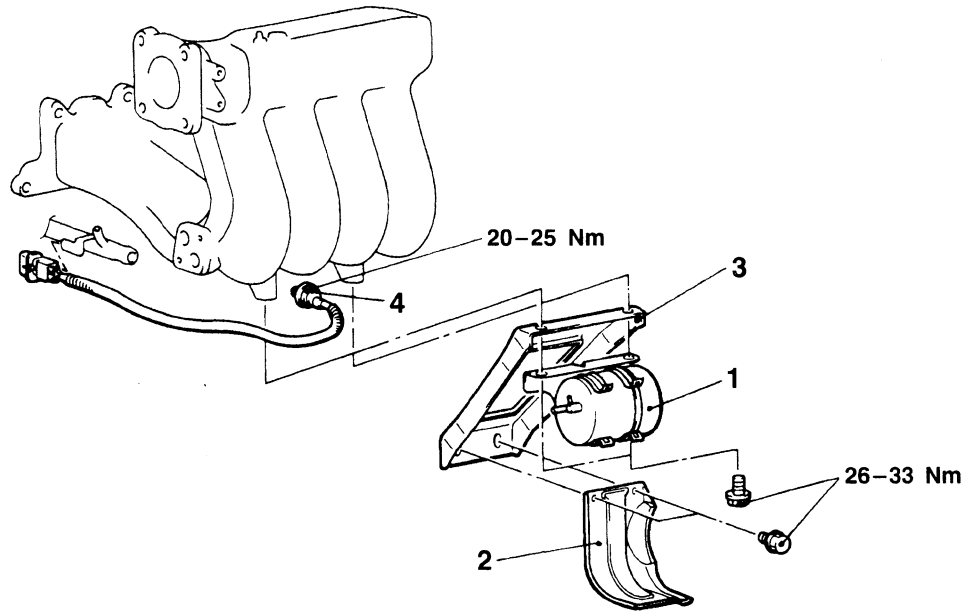

A16U0120

Removal steps

1. Vacuum tank and vacuum tank bracket assembly
<Vehicles with TCL>
2. Heat protector <4G93-M/T>
3. Intake manifold stay
4. Detonation sensor

Caution

Do not subject the detonation sensor to any shocks.

INSPECTION

DETONATION SENSOR CHECK

Refer to GROUP 13A – Troubleshooting.

16300290048