CIRCUIT DIAGRAMS

CONTENTS

IGNITION SYSTEM

4G1 2

STARTING SYSTEM

Petrol-powered vehicles <MPI> 4

CHARGING SYSTEM

4G1 5

MPI SYSTEM

4G1 6

COOLING SYSTEM

Petrol-powered vehicles 14

METER AND GAUGE

Petrol-powered vehicles 16

OIL PRESSURE WARNING LAMP 19

MANUAL AIR CONDITIONER

Petrol-powered vehicles 20

AUTOMATIC AIR CONDITIONER

Petrol-powered vehicles 26

MULTI CENTER DISPLAY

Petrol-powered vehicles 34

IMMOBILIZER SYSTEM

Petrol-powered vehicles 40

IGNITION SYSTEM

4G1

1

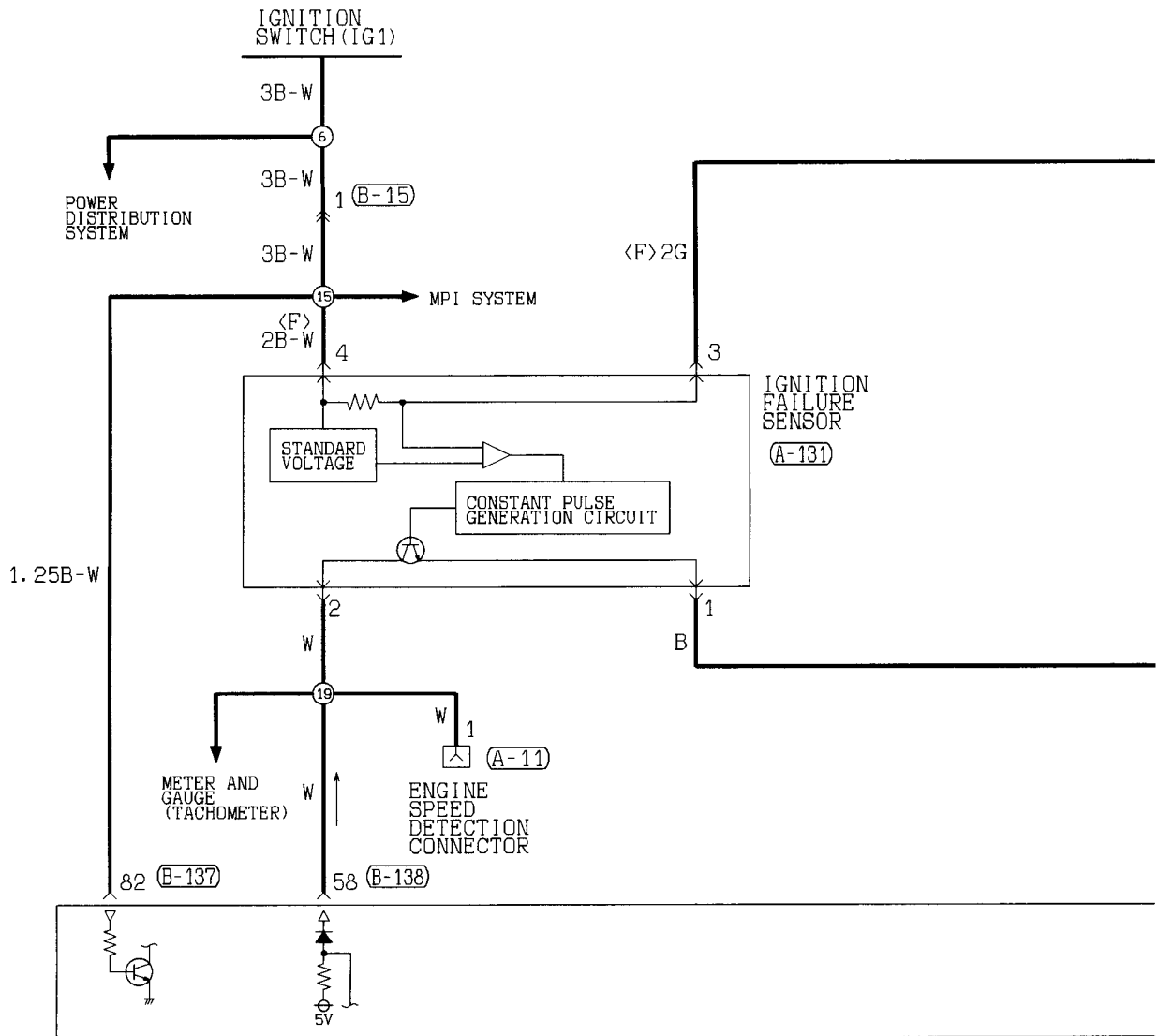

INPUT SIGNAL		
· CRANK ANGLE SENSOR	· ENGINE COOLANT TEMPERATURE SENSOR	· INTAKE AIR TEMPERATURE SENSOR
· CAMSHAFT POSITION SENSOR	· IGNITION SWITCH (ST)	· VACUUM SENSOR
· DETONATION SENSOR		· VEHICLE SPEED SENSOR

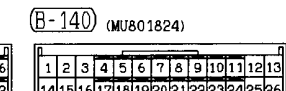
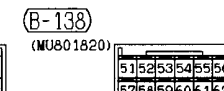
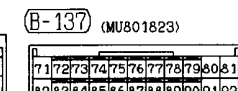
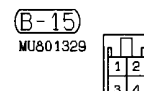
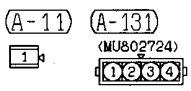
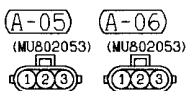

2

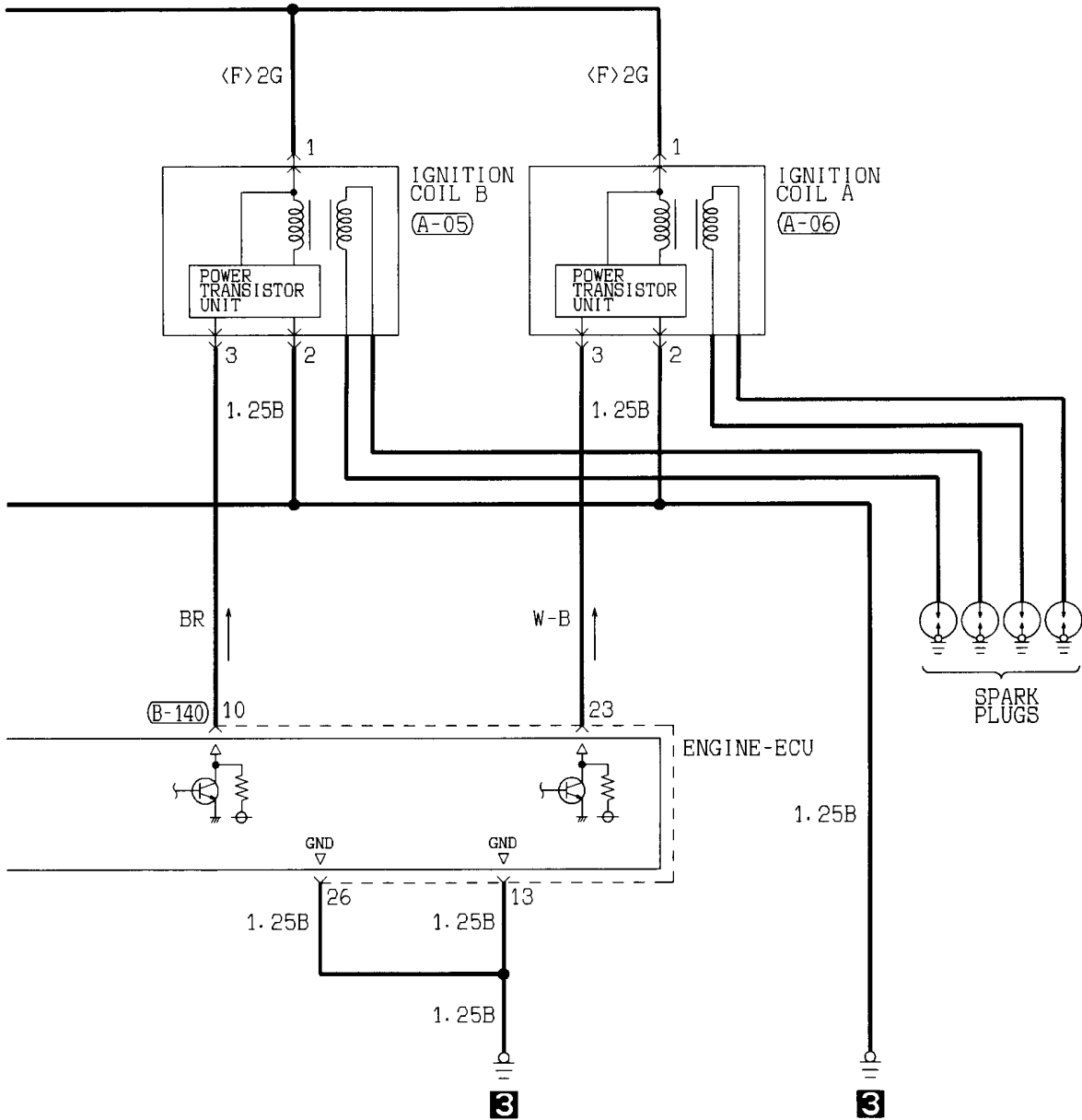

Wire colour code
 B :Black LG:Light green G :Green L :Blue W :White Y :Yellow SB:Sky blue
 BR:Brown O :Orange GR:Gray R :Red P :Pink V :Violet

STARTING SYSTEM

Petrol-powered vehicles <MPI>

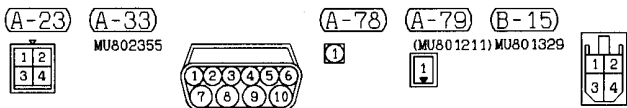
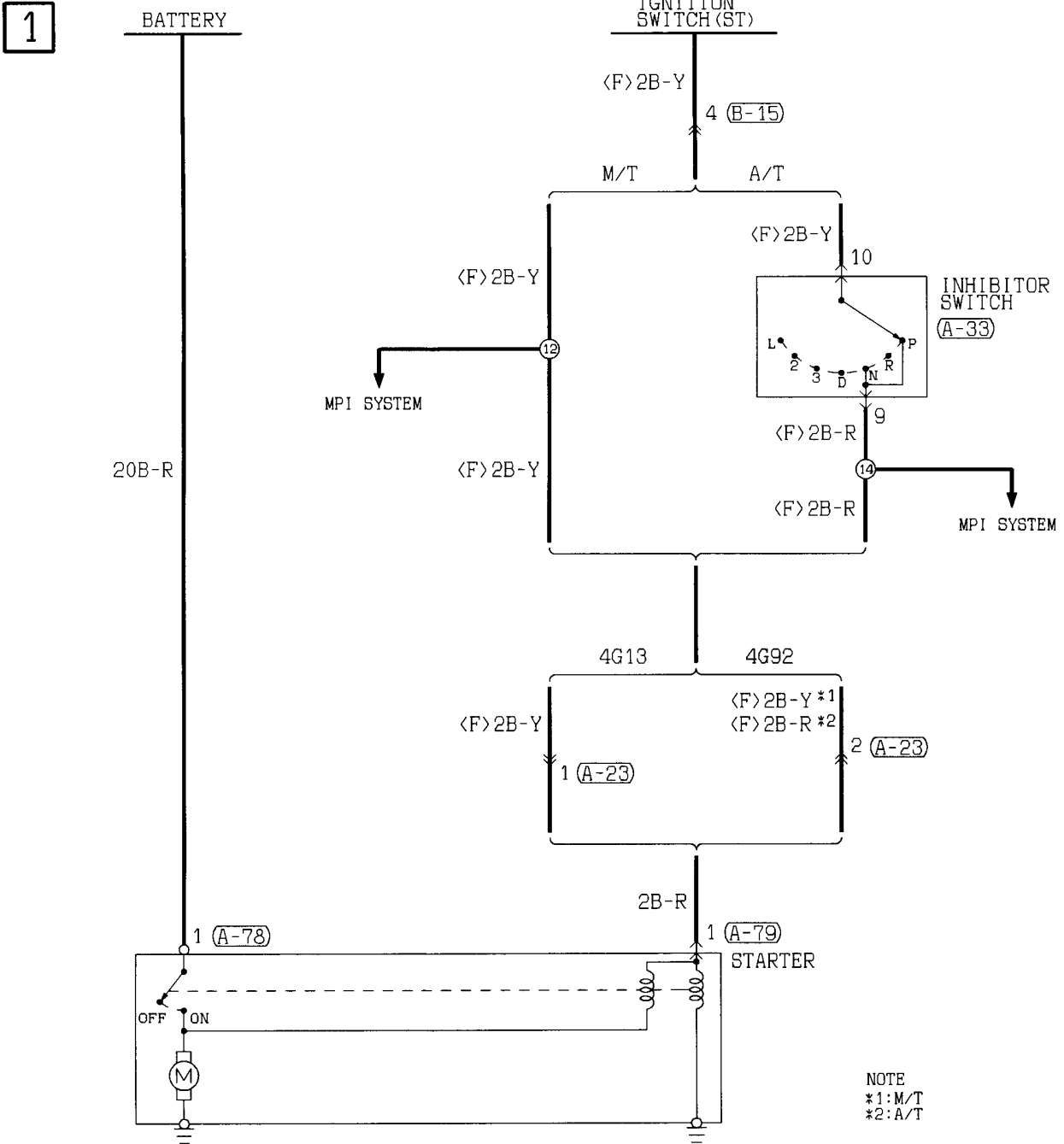

Wire colour code
 B:Black LG:Light green G:Green L:Blue W:White Y:Yellow SB:Sky blue
 BR:Brown O:Orange GR:Gray R:Red P:Pink V:Violet

CHARGING SYSTEM

4G1

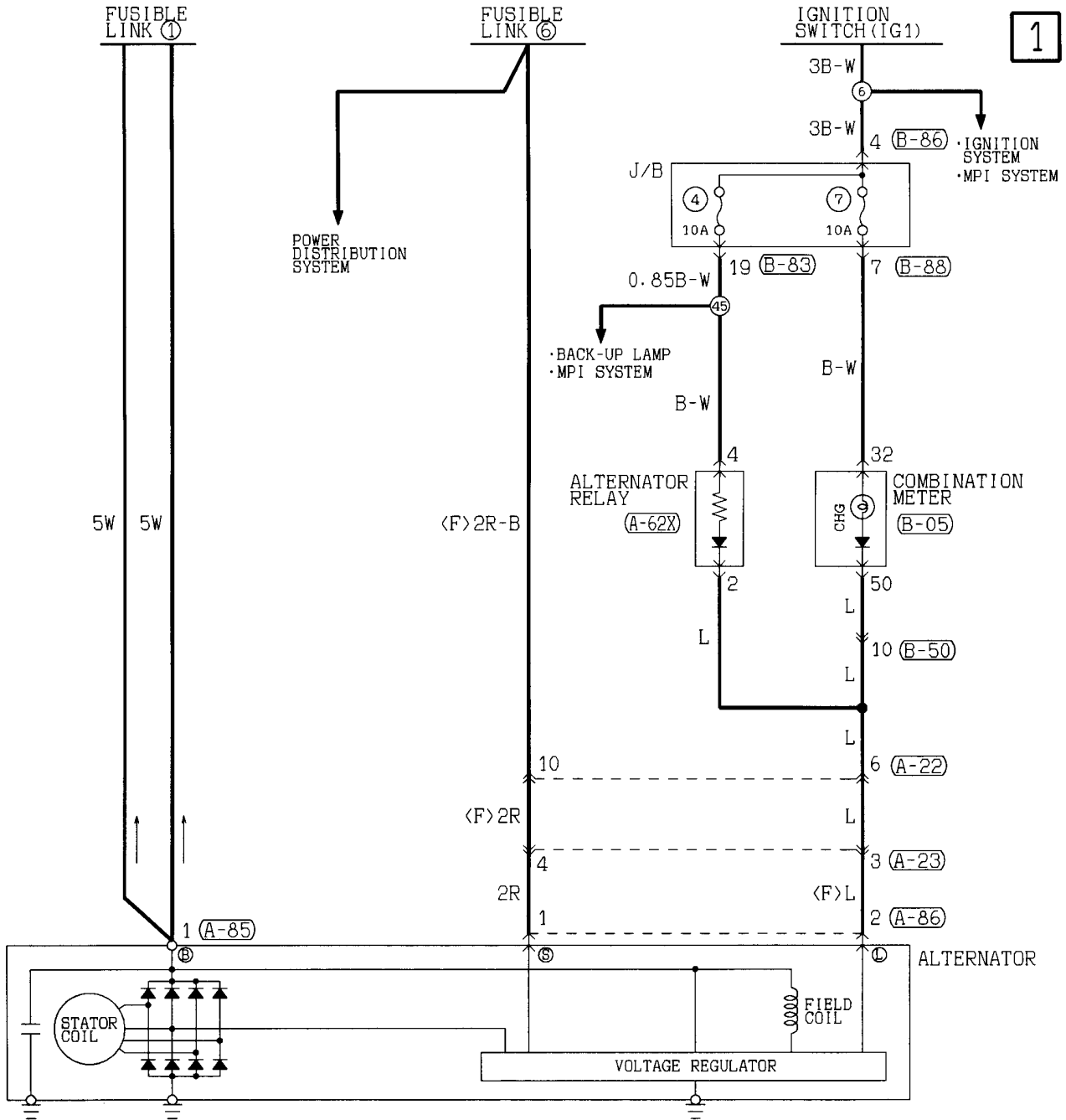

(A-22) MU802355	(A-23) 1 2 3 4	(A-62X) 1 2 3 4	(A-85) 1	(A-86) 1 2	(B-05) 3 1 3 2 3 3 3 4 3 5 3 6 3 7 3 8 3 9 4 0 4 1 4 2 4 3 4 4 4 5 4 6 4 7 4 8 4 9 5 0 5 1 5 2 5 3 5 4 5 5	(B-50) MU801461	(B-83) MU801457
(B-86) 1 2 3 4 5 6 7 8 9 10 11 12 13 14 15 16 17 18	(B-88) MU801465	Wire colour code B : Black BR : Brown W : White V : Violet		LG : Light green O : Orange SB : Sky blue	G : Green GR : Gray P : Pink	L : Blue R : Red Y : Yellow	H2T04E00AA

MPI SYSTEM

4G1

1

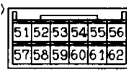
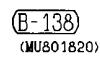
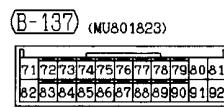
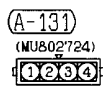
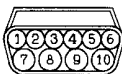
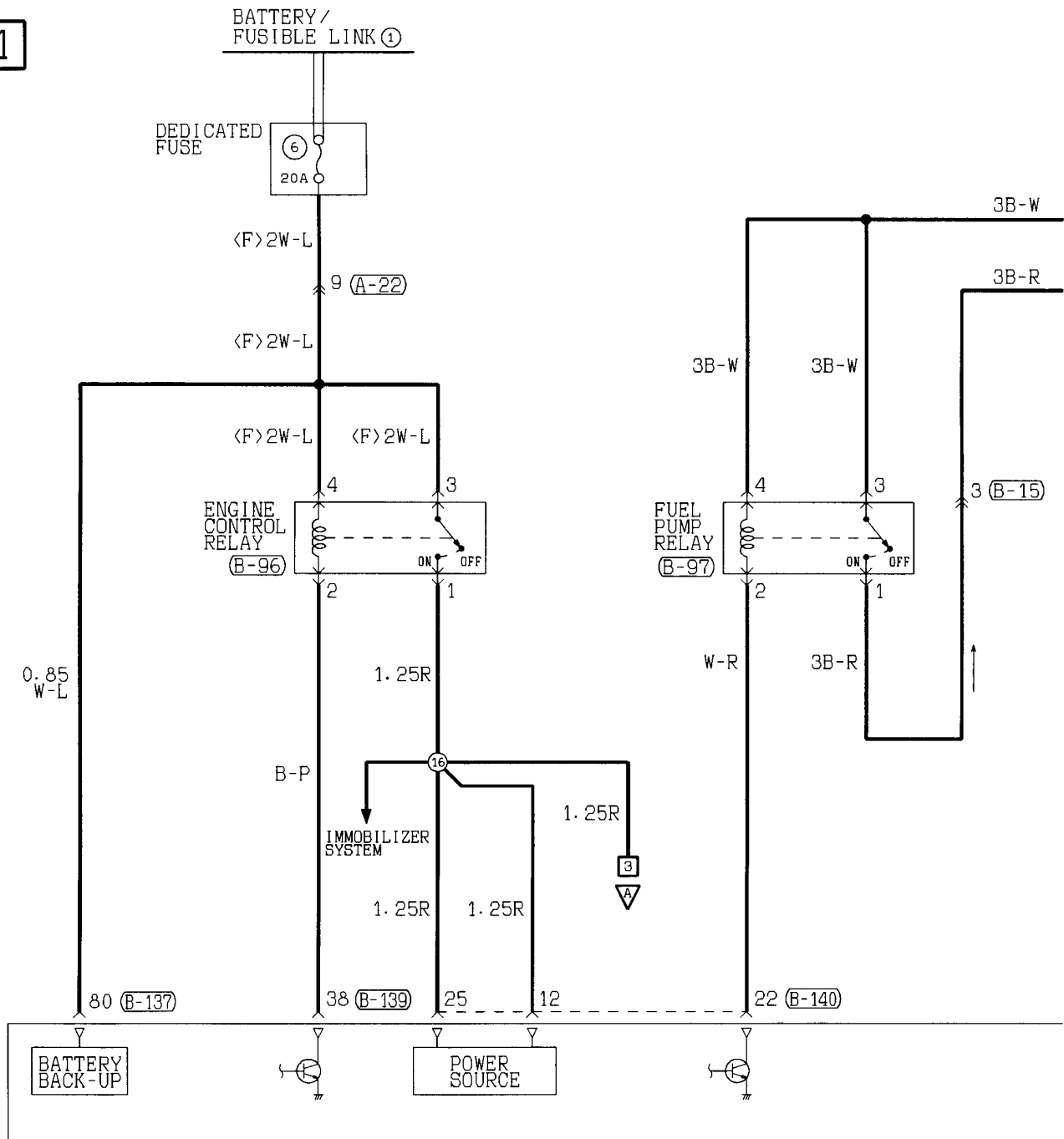

2

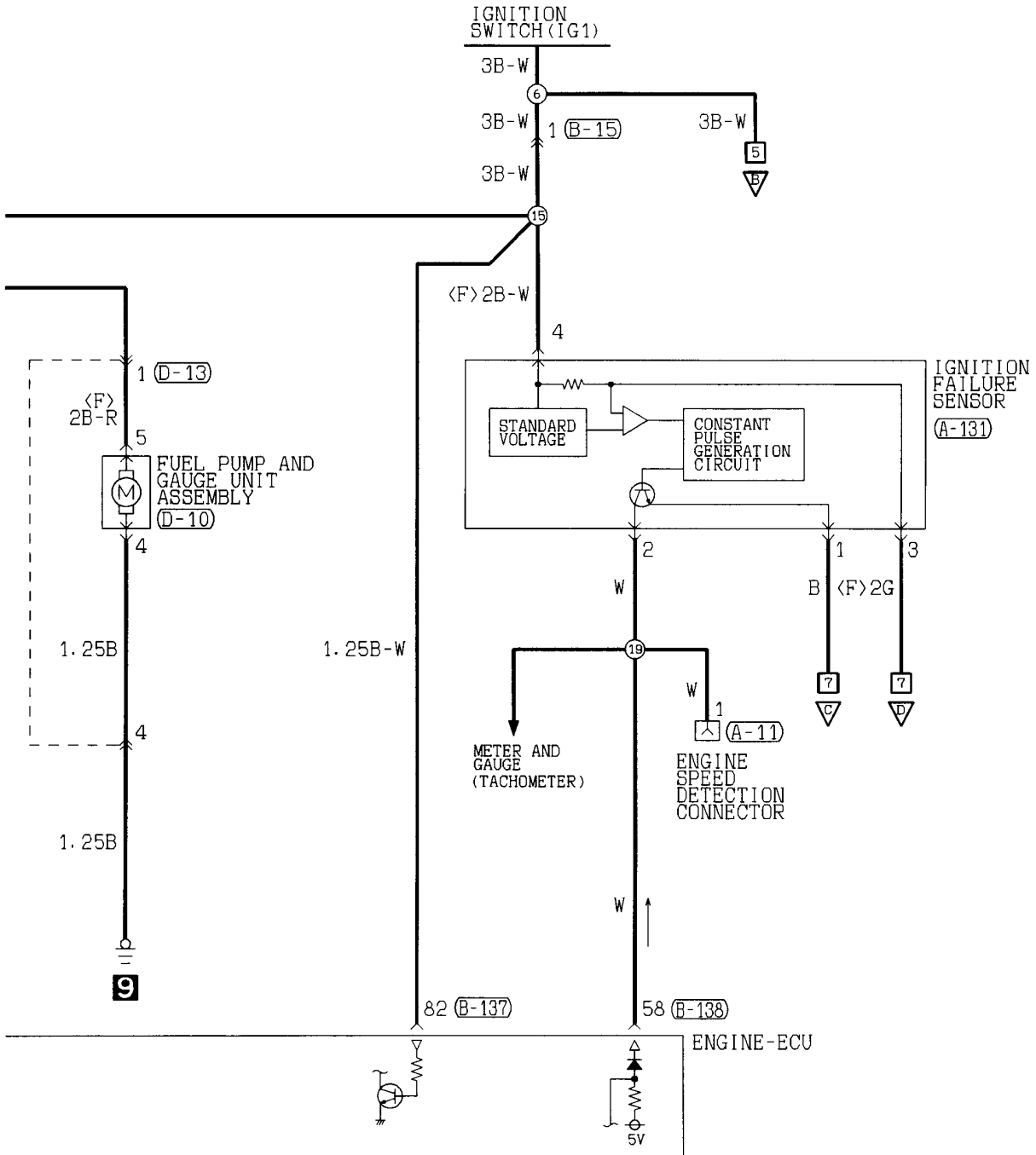

(B-139) (MU801822)

(B-140) (MU801824)

(D-10) (D-13)

31	32	33	34	35	36	37	38
39	40	41	42	43	44	45	46

1	2	3	4	5	6	7	8	9	10	11	12	13
14	15	16	17	18	19	20	21	22	23	24	25	26

(MU802058)

1	2	3
4	5	6

MU801451

1	2	3	4		
5	6	7	8	9	10

Wire colour code

B :Black LG:Light green G :Green L :Blue W :White Y :Yellow SB:Sky blue
 BR:Brown O :Orange GR:Gray R :Red P :Pink V :Violet

MPI SYSTEM <4G1> (CONTINUED)

3

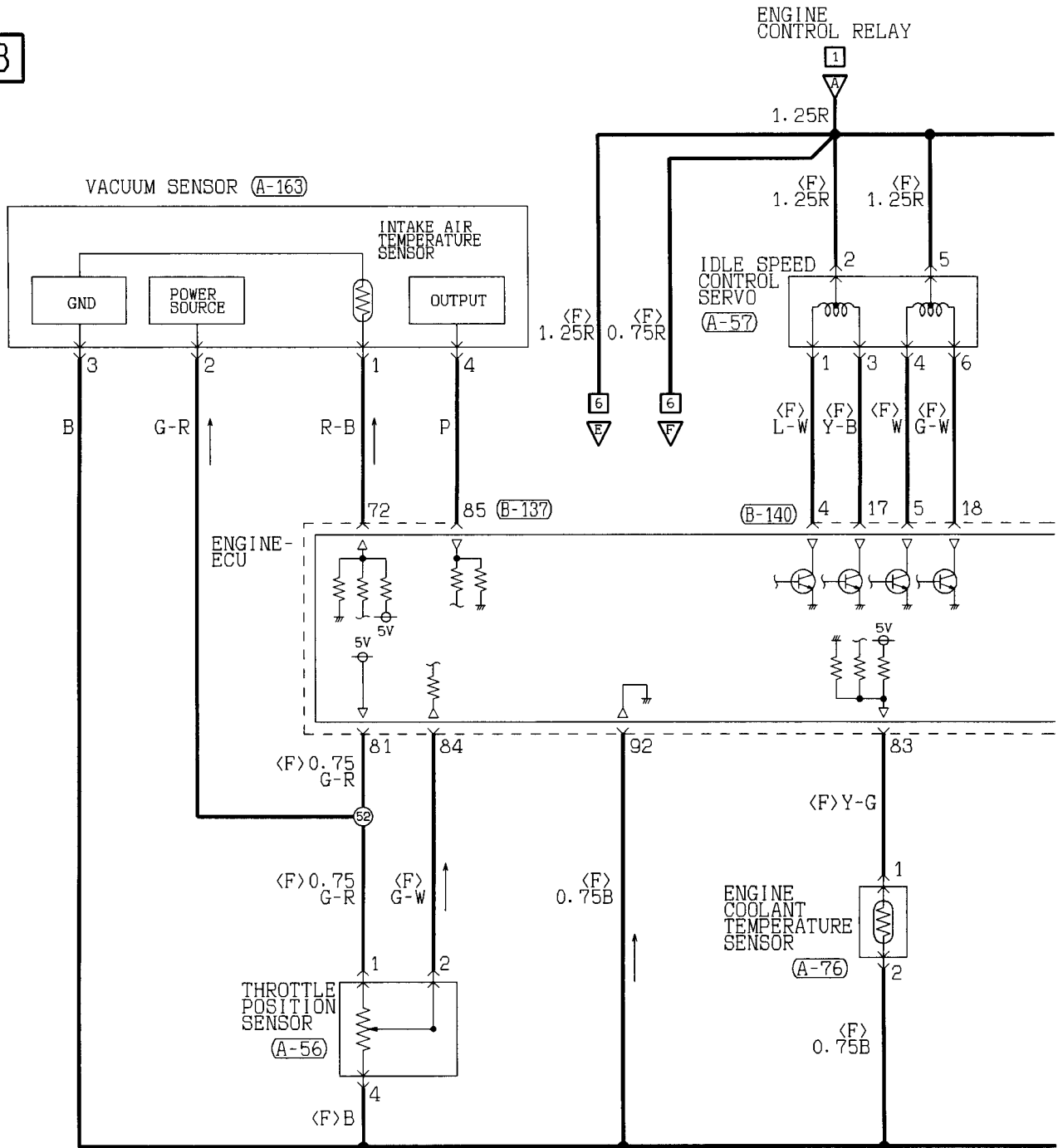

- (A-14) MU802779
- (A-15)
- (A-51)
- (A-52)
- (A-53)
- (A-54)
- (A-56) (MU802724)
- (A-57)
- (A-76) (MU802406)
- (A-126) MU802605
- (A-163)
- (B-132) MU801446

4

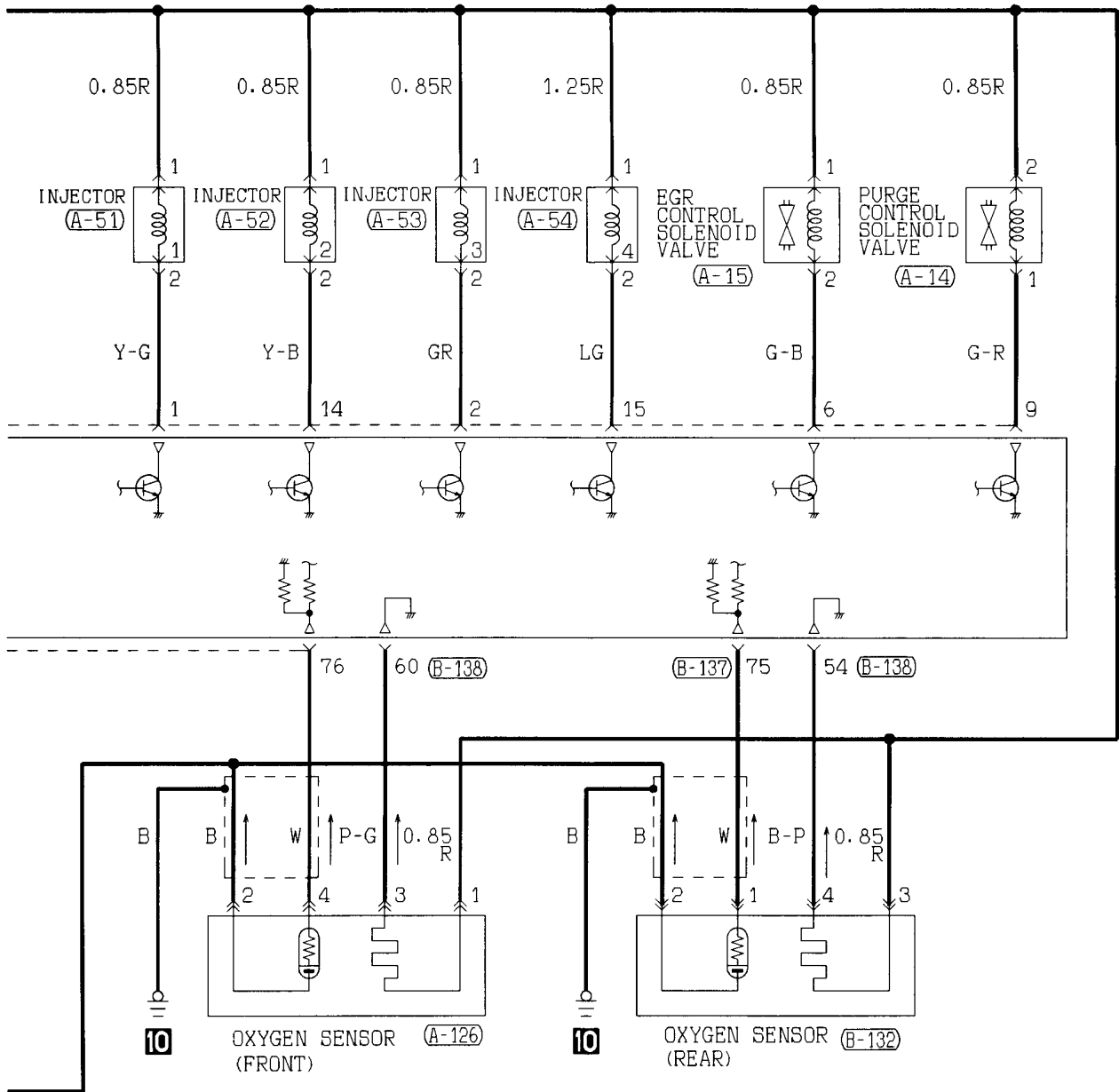

(B-137) (MU801823)

71	72	73	74	75	76	77	78	79	80	81
82	83	84	85	86	87	88	89	90	91	92

(B-138) (MU801820)

51	52	53	54	55	56
57	58	59	60	61	62

(B-140) (MU801824)

1	2	3	4	5	6	7	8	9	10	11	12	13
14	15	16	17	18	19	20	21	22	23	24	25	26

Wire colour code
 B : Black LG : Light green G : Green L : Blue W : White Y : Yellow SB : Sky blue
 BR : Brown O : Orange GR : Gray R : Red P : Pink V : Violet

MPI SYSTEM <4G1> (CONTINUED)

5

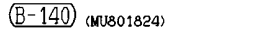
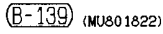
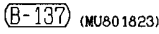
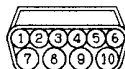
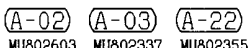
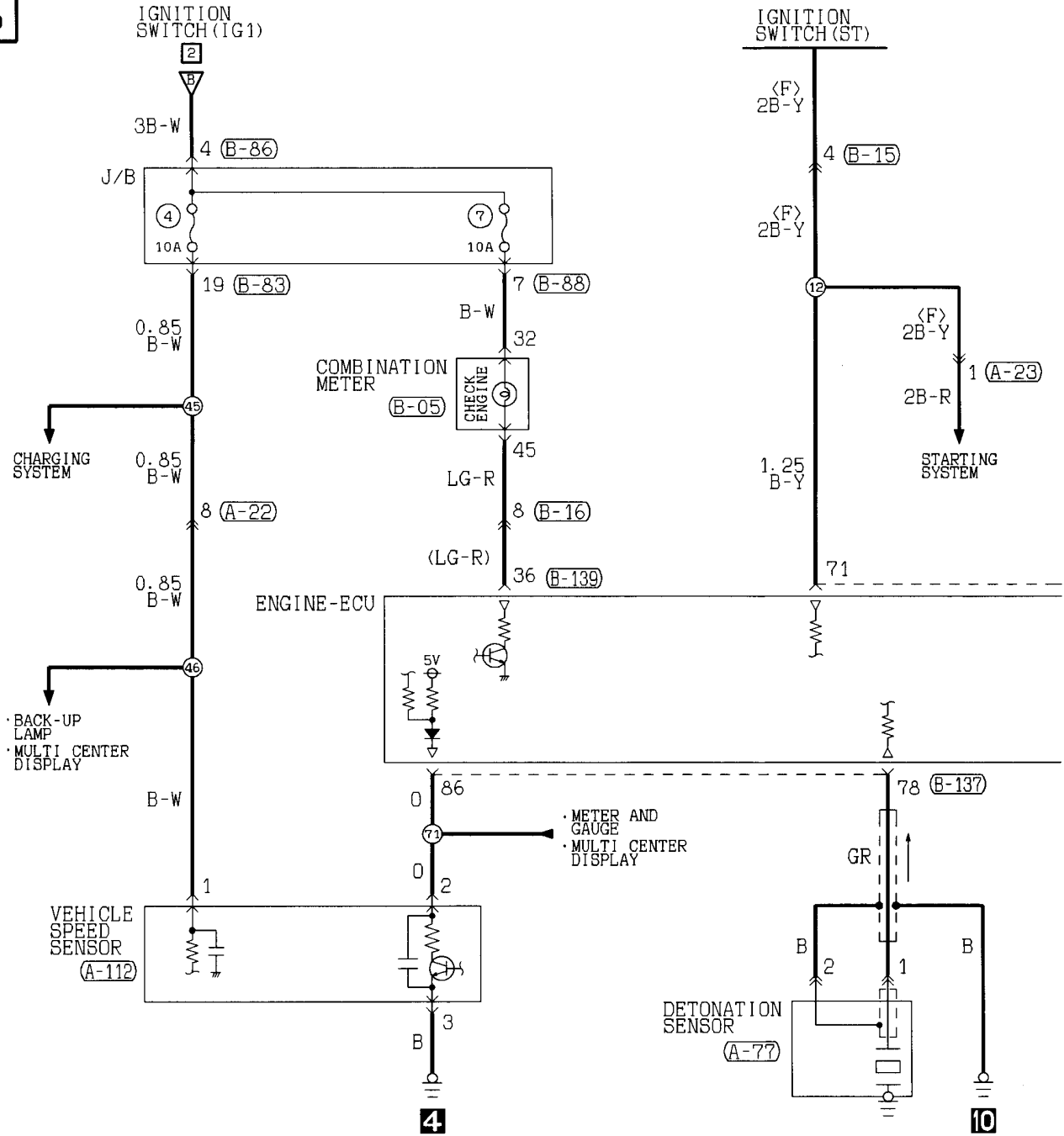

6

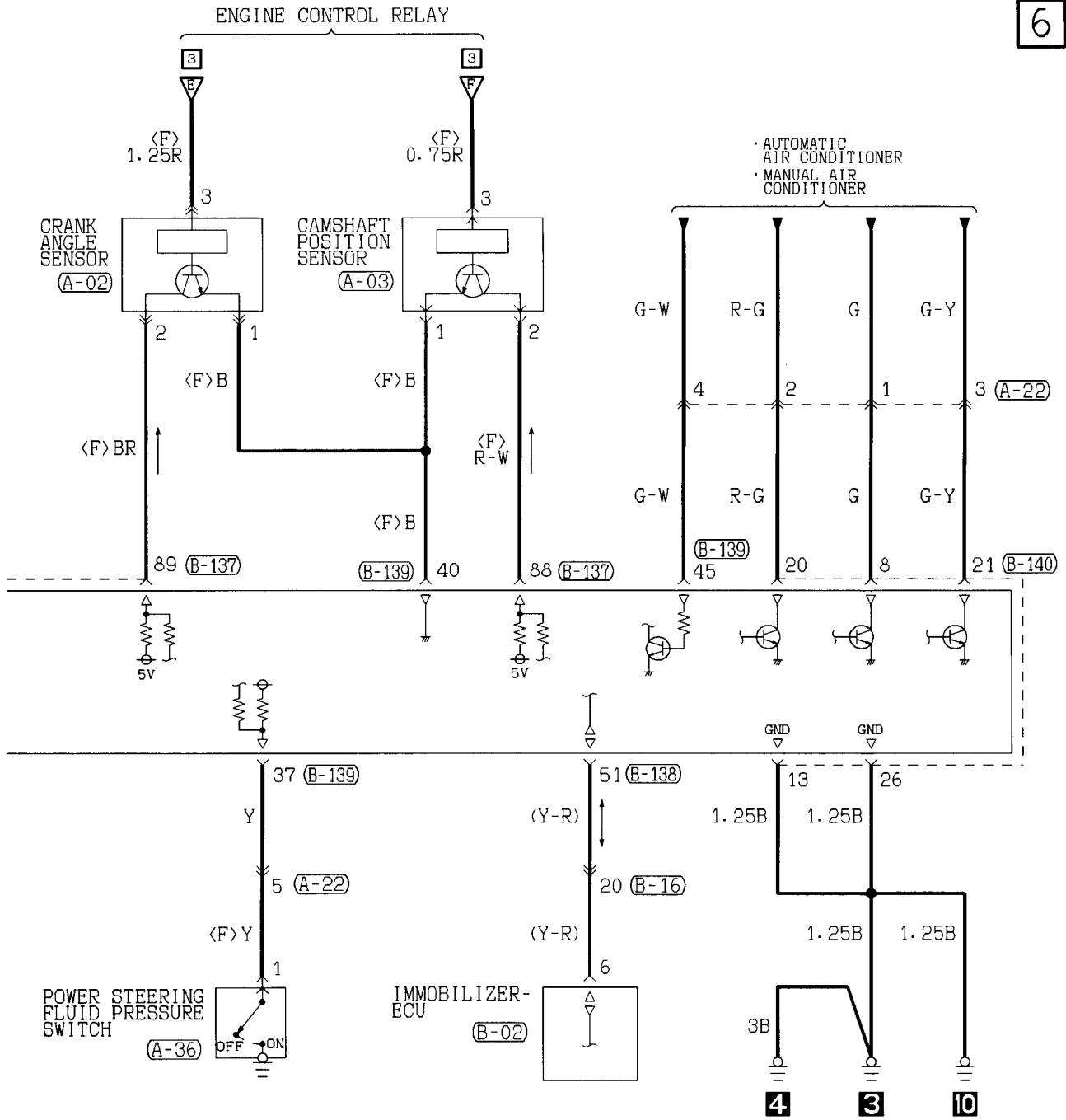

(B-15)
MU801329

1	2
3	4

(B-16)
MU801457

1	2	3	4	5	6	7	8	9		
10	11	12	13	14	15	16	17	18	19	20

(B-83)
MU801457

1	2	3	4	5	6	7	8	9		
10	11	12	13	14	15	16	17	18	19	20

(B-86)

1	2	3	4	5	6	7	8		
9	10	11	12	13	14	15	16	17	18

(B-88)

1	2	3	4	5	6	7	8	9	10		
11	12	13	14	15	16	17	18	19	20	21	22

Wire colour code
 B:Black LG:Light green G:Green L:Blue W:White Y:Yellow SB:Sky blue
 BR:Brown O:Orange GR:Gray R:Red P:Pink V:Violet

MPI SYSTEM <4G1> (CONTINUED)

7

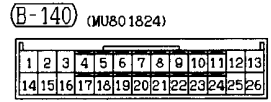
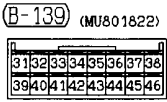
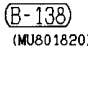
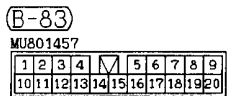
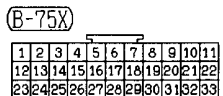
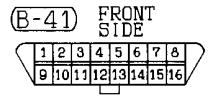
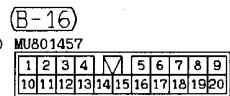
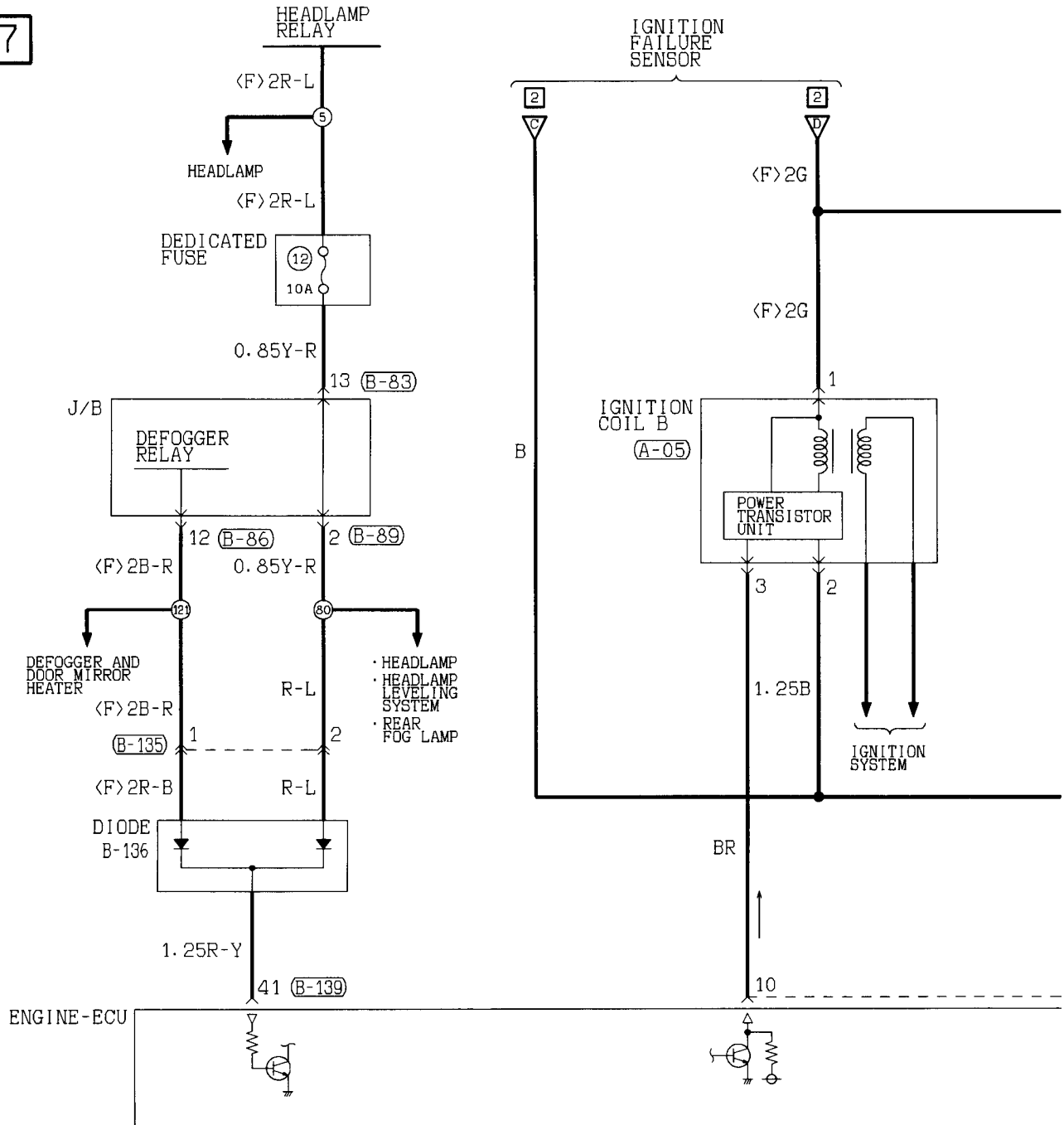

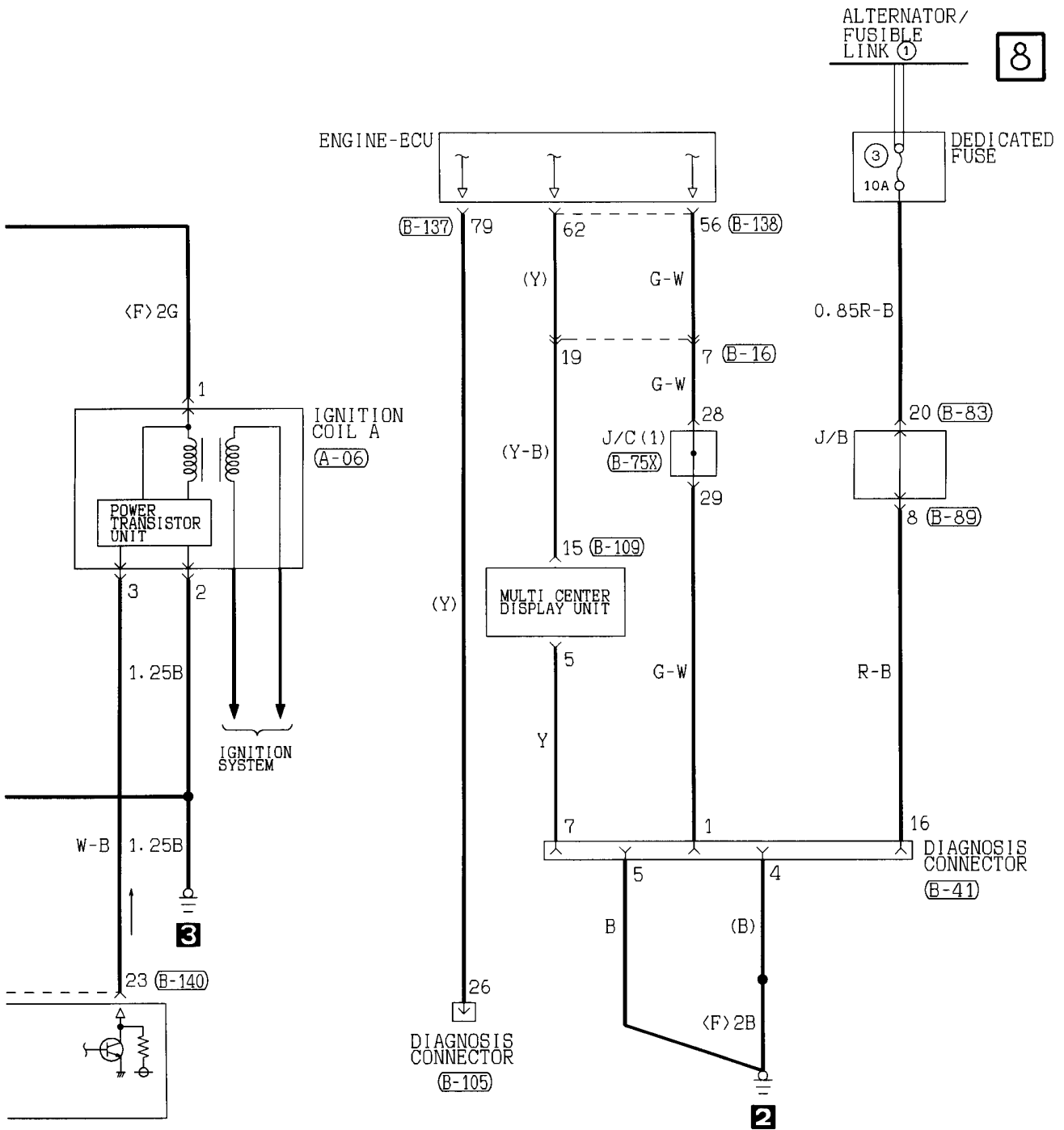

(B-86)

1	2	3	4	5	6	7	8
9	10	11	12	13	14	15	16
17	18						

(B-89)

1	2	3	4	5	6	7	8	9	10
11	12	13	14	15	16	17	18	19	20
21	22								

(B-105) FRONT SIDE

23	24	25	26	27	28	29
30	31	32				

(B-109) (MU801585)

1	2	3	4	5	6	7	8	9	10
11	12	13	14	15	16	17	18	19	20

(B-135)

1	2	3	4
---	---	---	---

(B-137) (MU801823)

71	72	73	74	75	76	77	78	79	80	81
82	83	84	85	86	87	88	89	90	91	92

Wire colour code

B :Black LG:Light green G :Green L :Blue W :White Y :Yellow SB:Sky blue
 BR:Brown O :Orange GR:Gray R :Red P :Pink V :Violet

COOLING SYSTEM

Petrol-powered vehicles

1

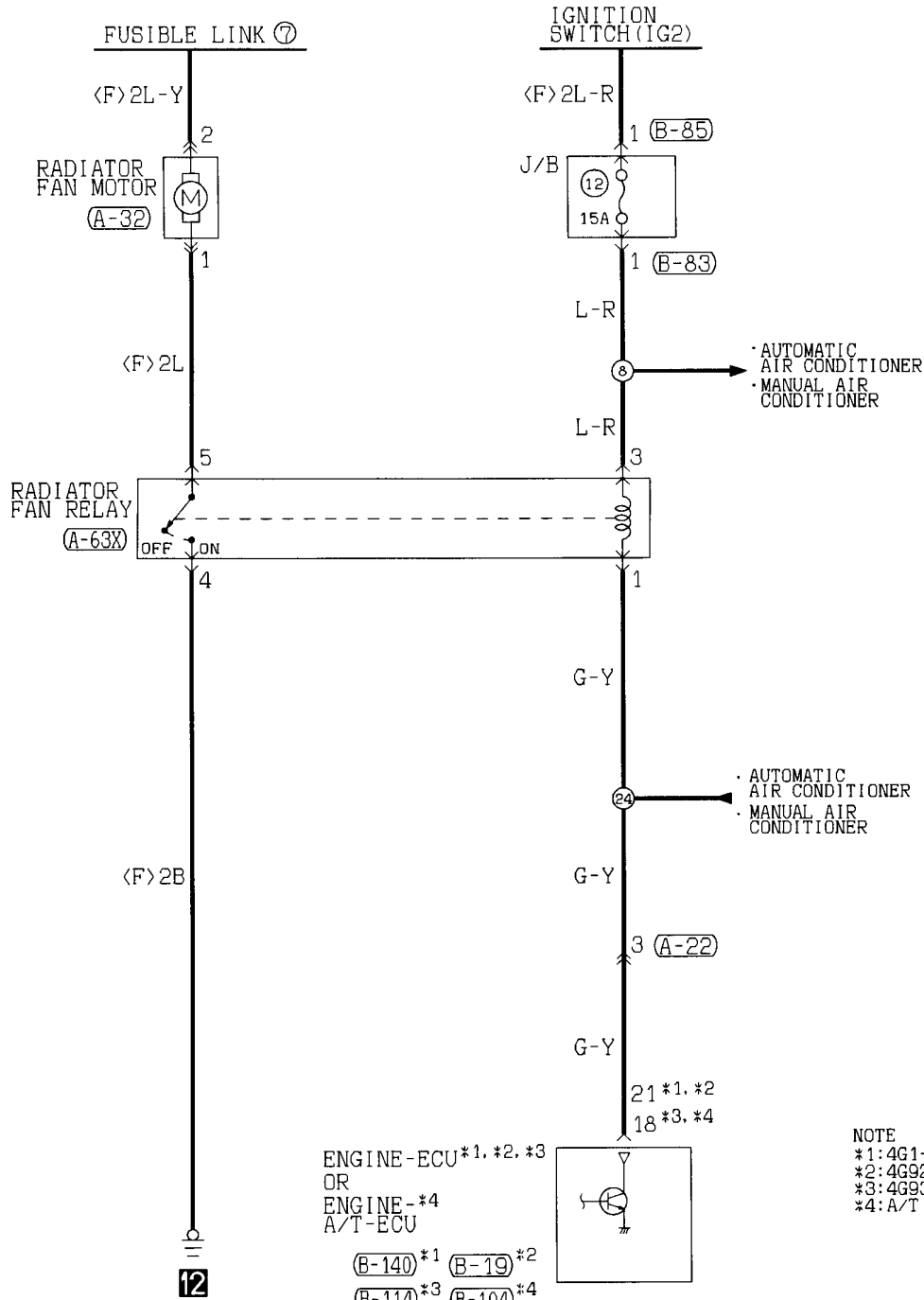

NOTE
 *1: 4G1-M/T
 *2: 4G92-M/T
 *3: 4G93-M/T
 *4: A/T

ENGINE-ECU *1, *2, *3
 OR
 ENGINE-*4
 A/T-ECU

(B-140) *1 (B-19) *2
 (B-114) *3 (B-104) *4

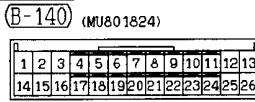
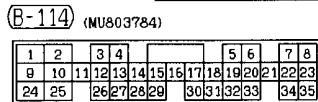
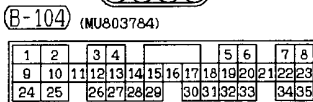
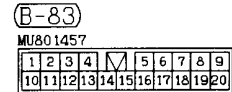
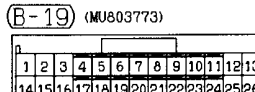

NOTES

METER AND GAUGE

Petrol-powered vehicles

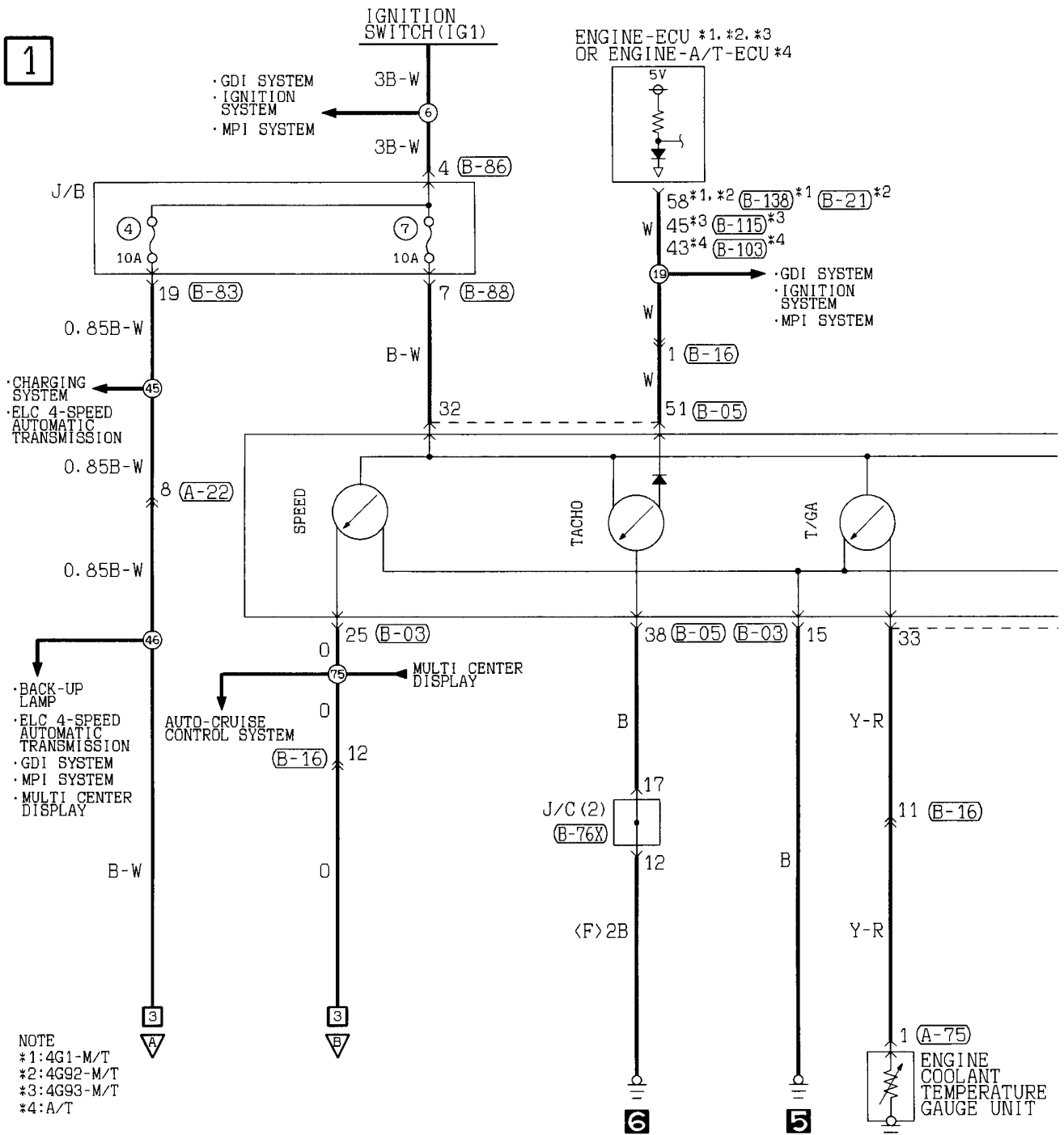

NOTE
*1:4G1-M/T
*2:4G92-M/T
*3:4G93-M/T
*4:A/T

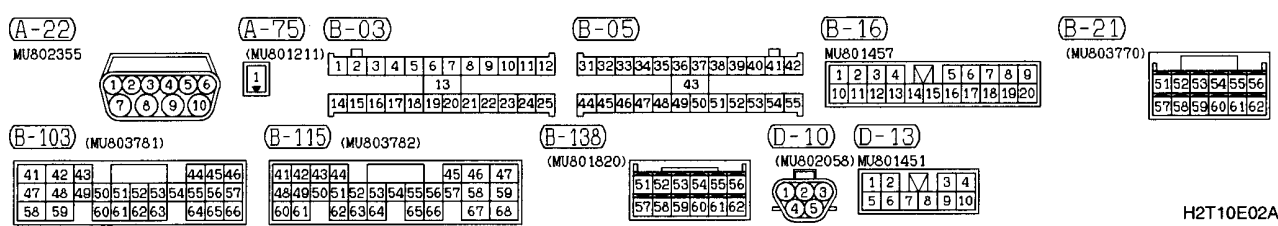

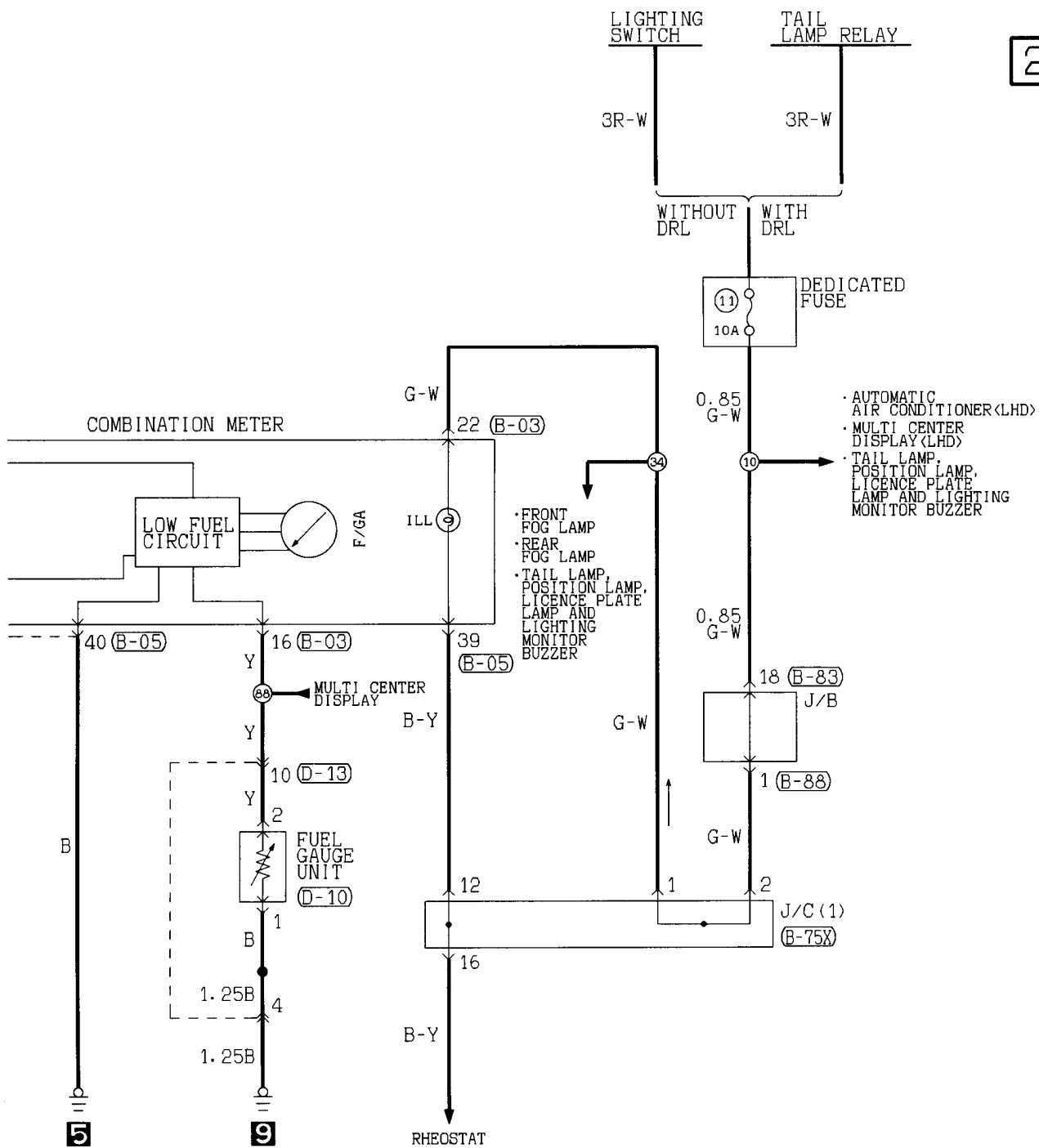

2

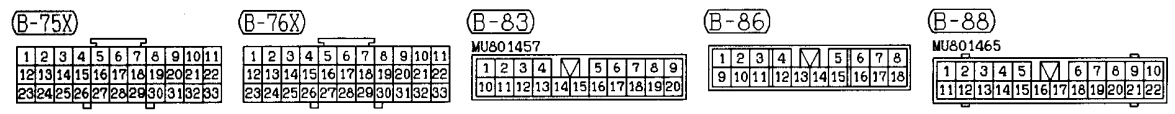

Wire colour code
 B:Black LG:Light green G:Green L:Blue W:White Y:Yellow SB:Sky blue
 BR:Brown O:Orange GR:Gray R:Red P:Pink V:Violet

METER AND GAUGE <Petrol-powered vehicles> (CONTINUED)

3

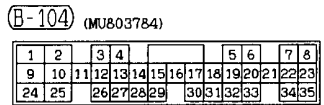
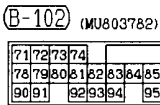
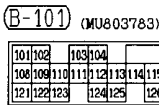
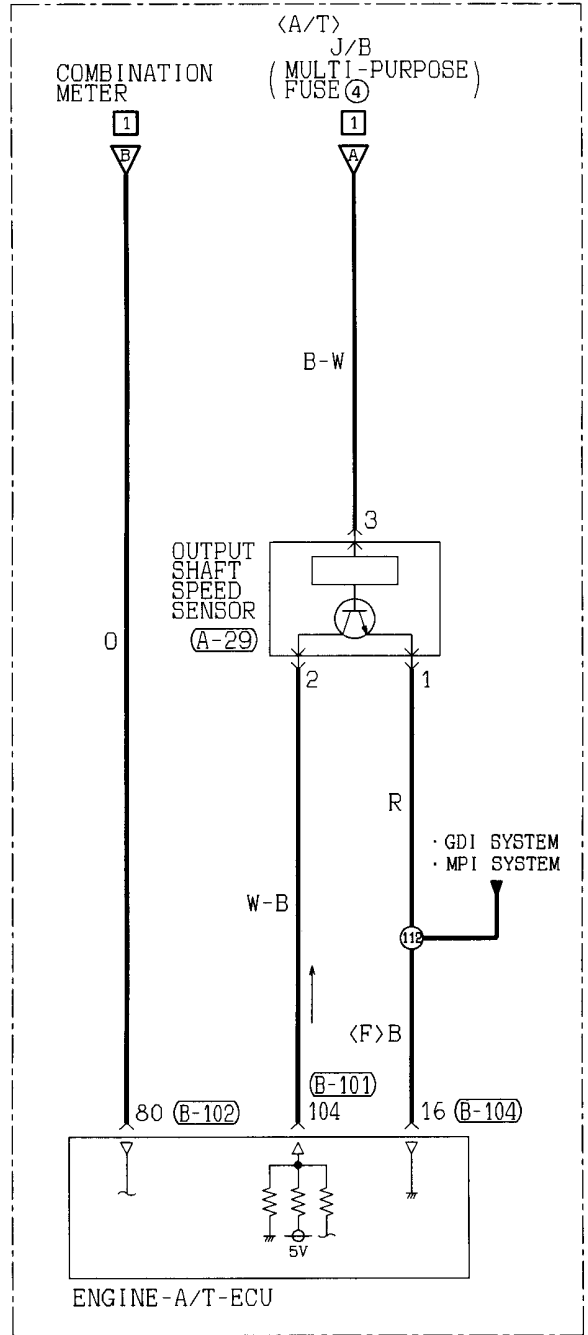
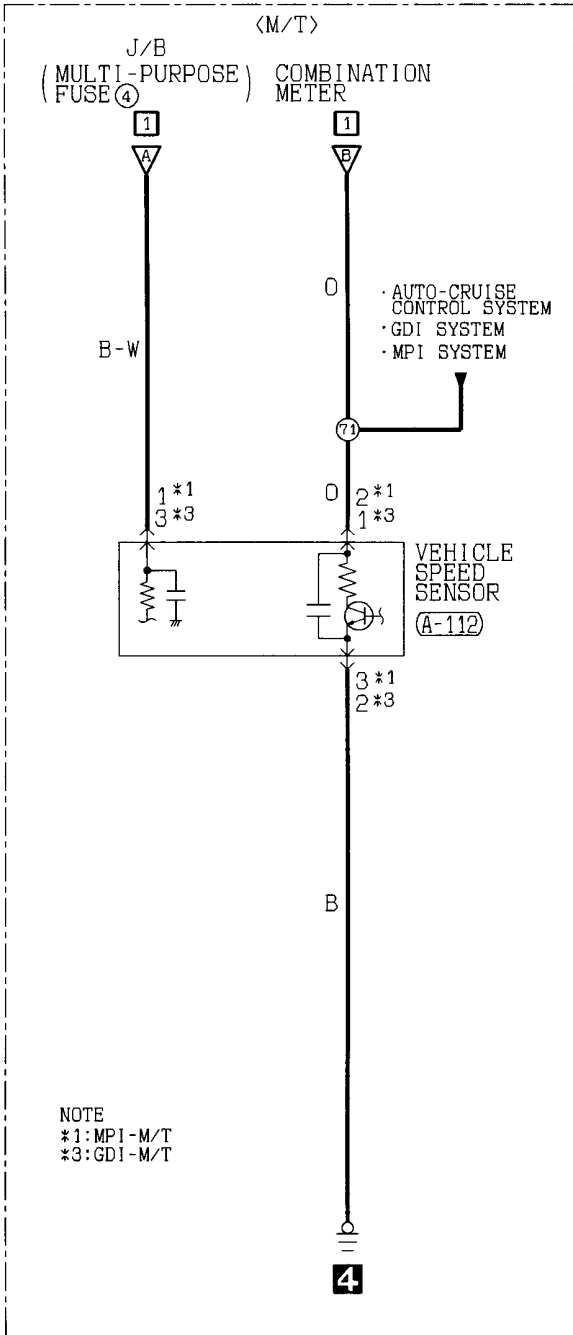

Wire colour code
 B : Black LG:Light green G : Green L : Blue W : White Y : Yellow SB:Sky blue
 BR:Brown O : Orange GR:Gray R : Red P : Pink V : Violet

OIL PRESSURE WARNING LAMP

1

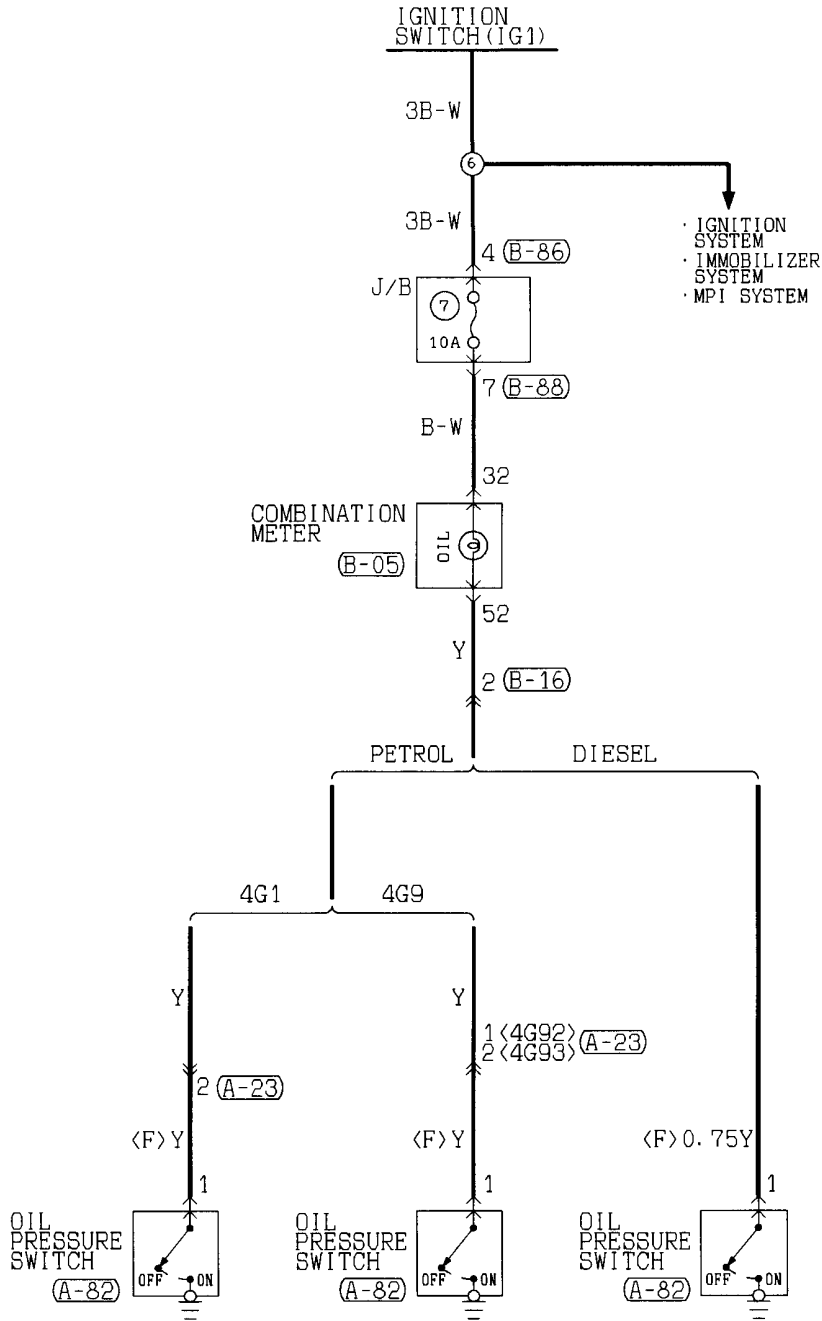

(A-23)

1	2
3	4

<4G1, 4G92>

(A-82)

1	2	3
4	5	6

<4G93>

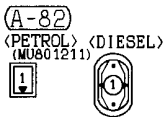

(B-05)

31	32	33	34	35	36	37	38	39	40	41	42
43											
44	45	46	47	48	49	50	51	52	53	54	55

(B-16)

1	2	3	4	5	6	7	8	9		
10	11	12	13	14	15	16	17	18	19	20

MU801457

(B-86)

1	2	3	4	5	6	7	8		
9	10	11	12	13	14	15	16	17	18

(B-88)

1	2	3	4	5	6	7	8	9	10		
11	12	13	14	15	16	17	18	19	20	21	22

MU801465

Wire colour code
 B :Black LG:Light green G :Green L :Blue W :White Y :Yellow SB:Sky blue
 BR:Brown O :Orange GR:Gray R :Red P :Pink V :Violet

MANUAL AIR CONDITIONER

Petrol-powered vehicles

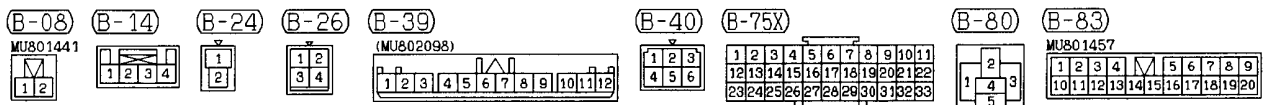
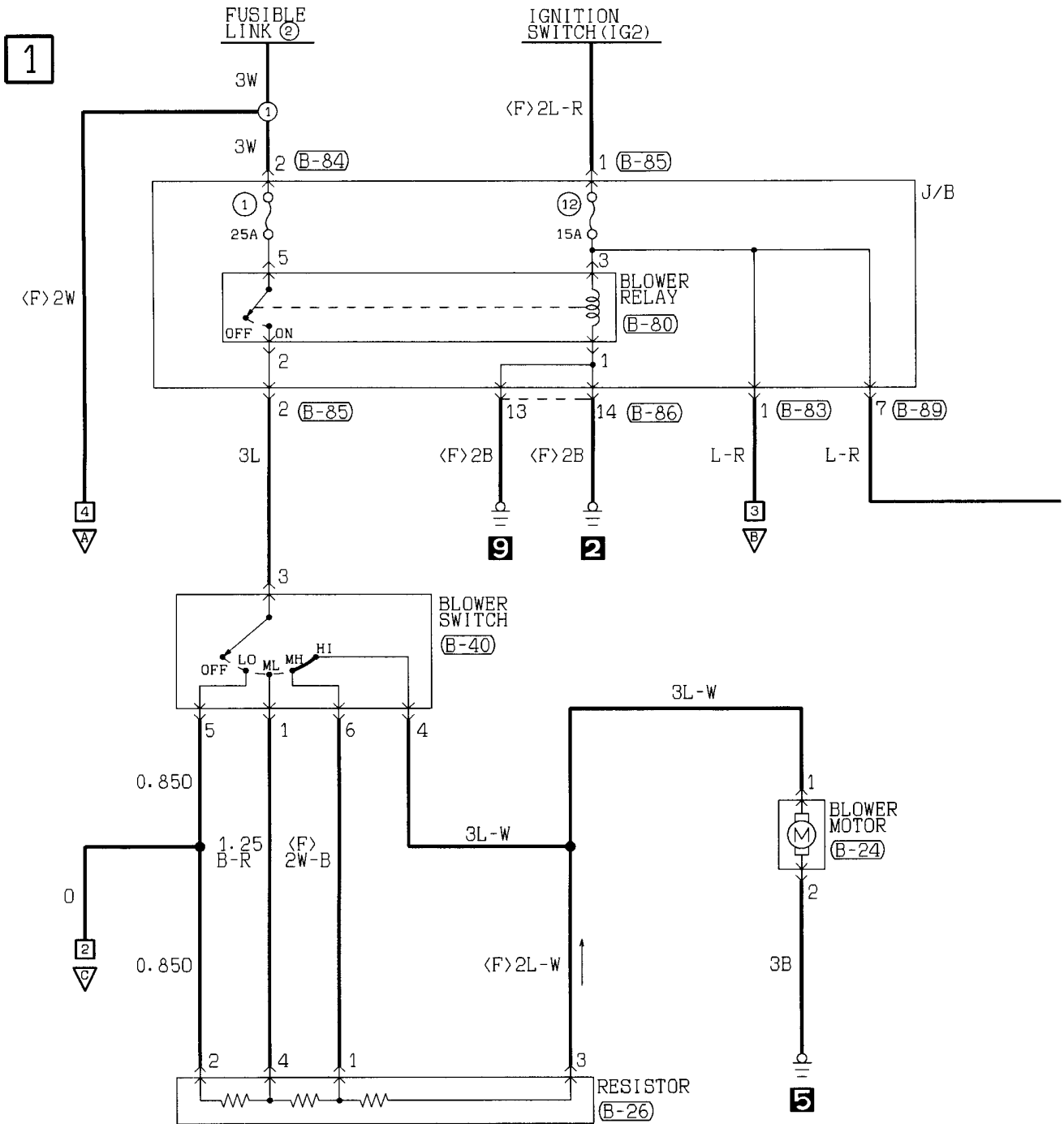

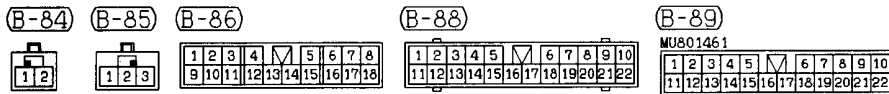
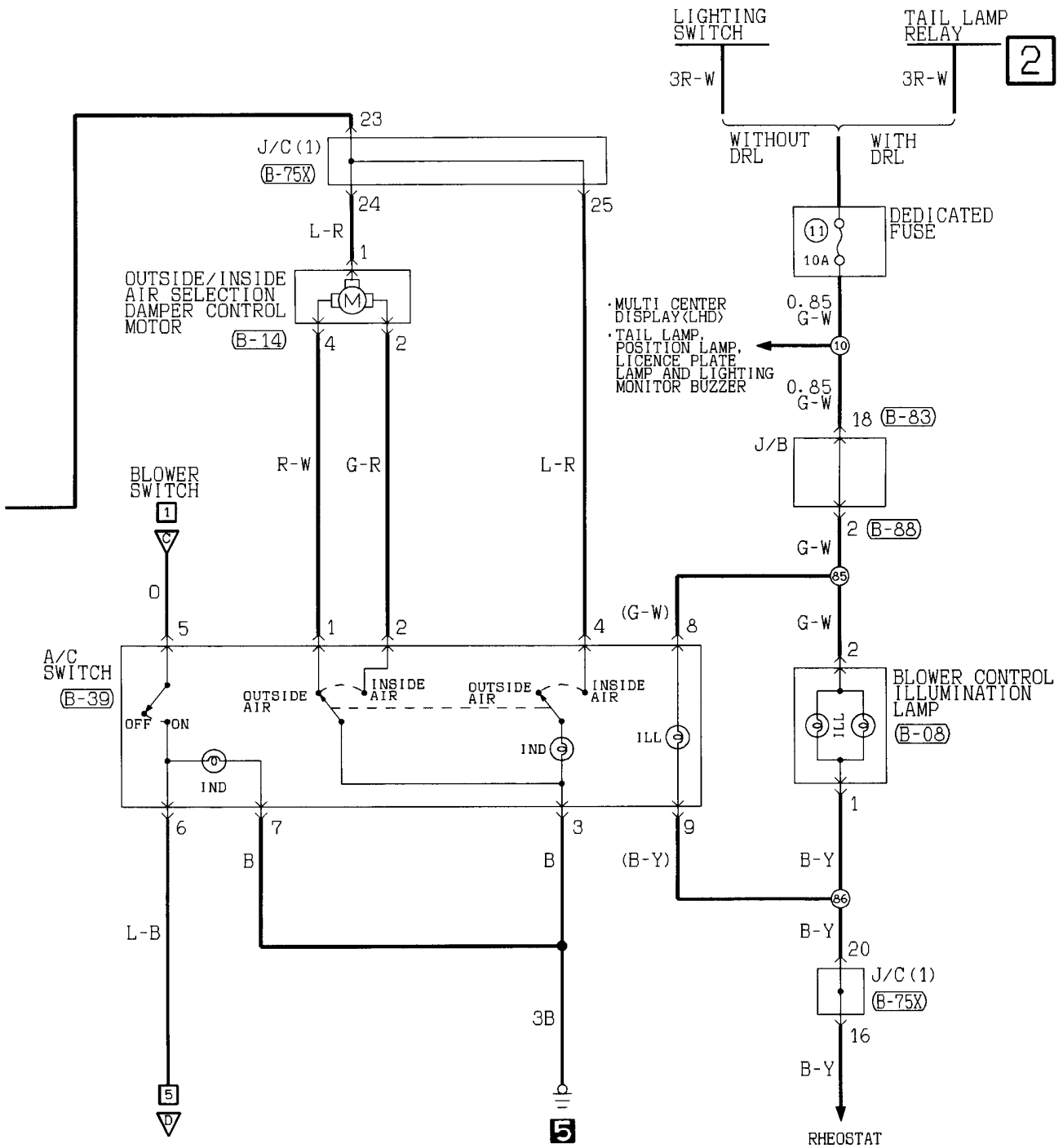

Wire colour code
 B : Black LG: Light green G : Green L : Blue W : White Y : Yellow SB: Sky blue
 BR: Brown O : Orange GR: Gray R : Red P : Pink V : Violet

MANUAL AIR CONDITIONER <Petrol-powered vehicles> (CONTINUED)

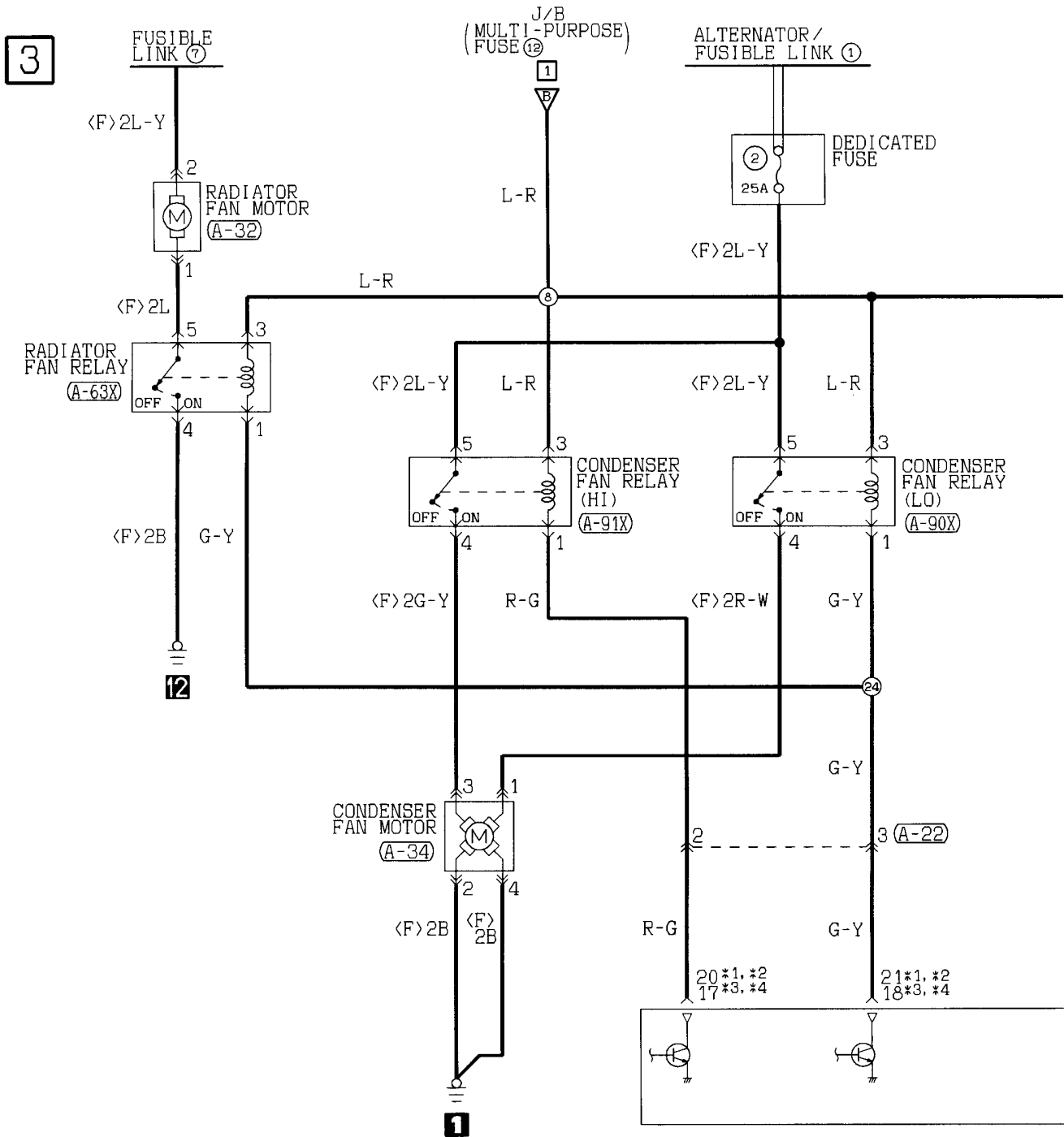

(A-22)
MU802355

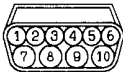

(A-32)
MU802601



(A-34)
MU802665



(A-63X)



(A-81)
MU802653



(A-90X)



(A-91X)



(A-92X)



(B-19) (MU803773)

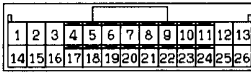

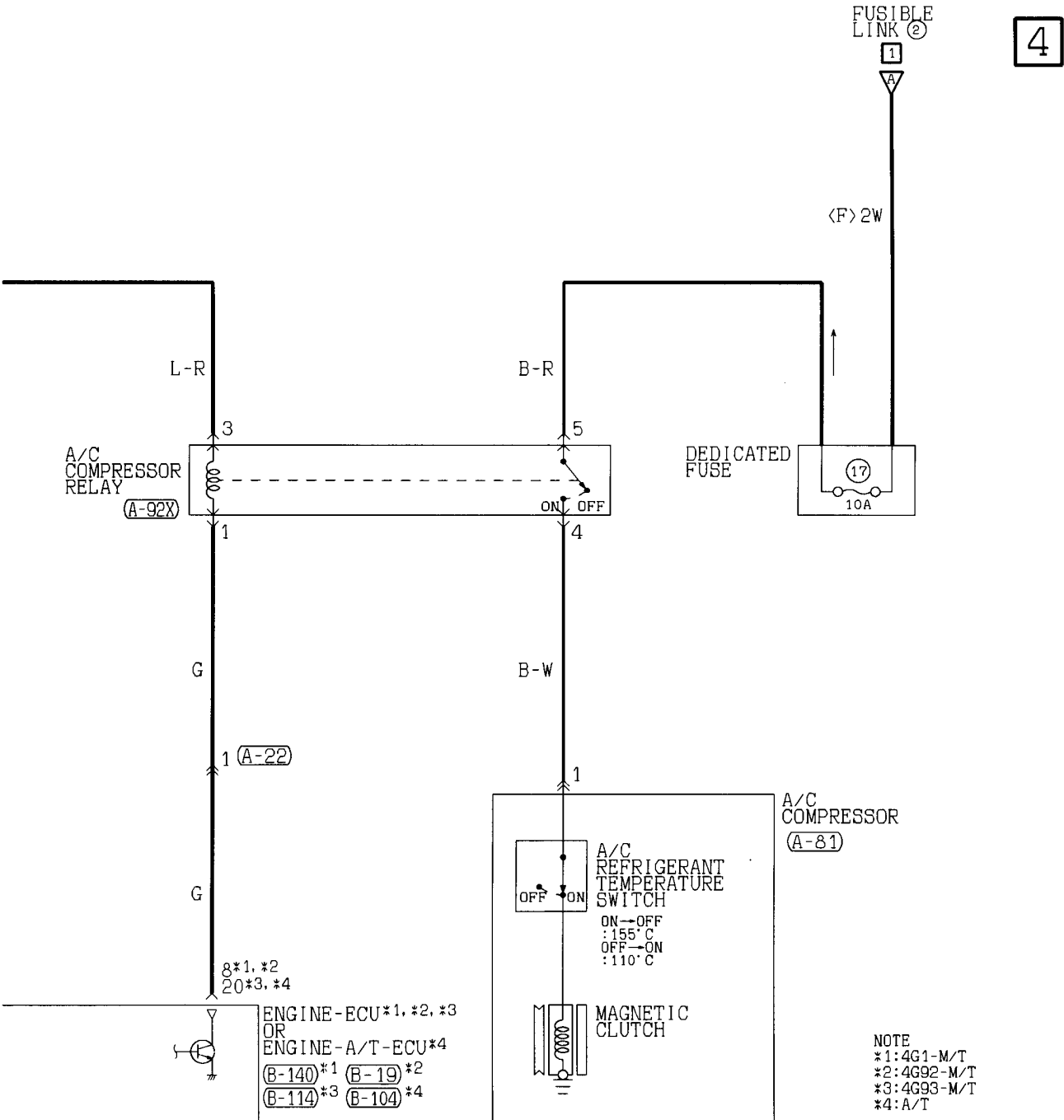

B-104 (MU803784)

1	2	3	4	5	6	7	8							
9	10	11	12	13	14	15	16	17	18	19	20	21	22	23
24	25	26	27	28	29	30	31	32	33	34	35			

B-114 (MU803784)

1	2	3	4	5	6	7	8							
9	10	11	12	13	14	15	16	17	18	19	20	21	22	23
24	25	26	27	28	29	30	31	32	33	34	35			

B-140 (MU801824)

1	2	3	4	5	6	7	8	9	10	11	12	13
14	15	16	17	18	19	20	21	22	23	24	25	26

Wire colour code
 B : Black LG: Light green G : Green L : Blue W : White Y : Yellow SB: Sky blue
 BR: Brown O : Orange GR: Gray R : Red P : Pink V : Violet

MANUAL AIR CONDITIONER <Petrol-powered vehicles> (CONTINUED)

5

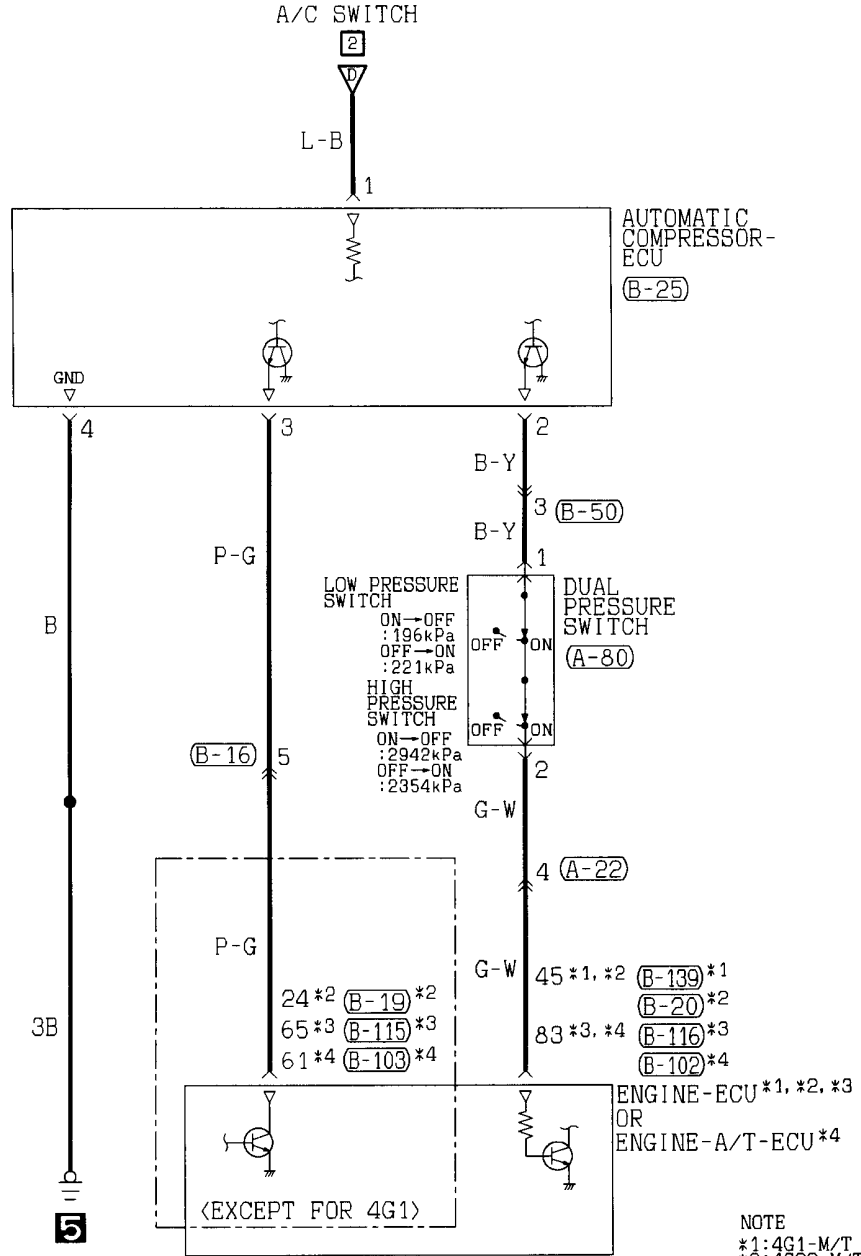

NOTE
 *1: 4G1-M/T
 *2: 4G92-M/T
 *3: 4G93-M/T
 *4: A/T

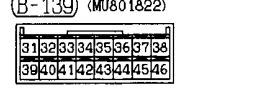
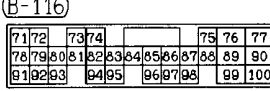
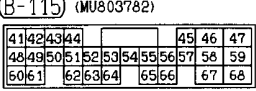
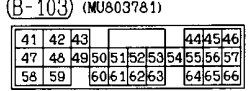
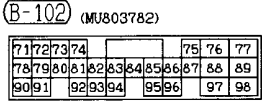
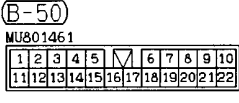
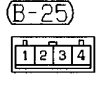
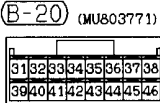
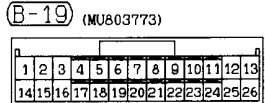
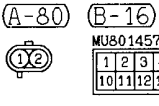
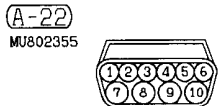

NOTES

AUTOMATIC AIR CONDITIONER

Petrol-powered vehicles

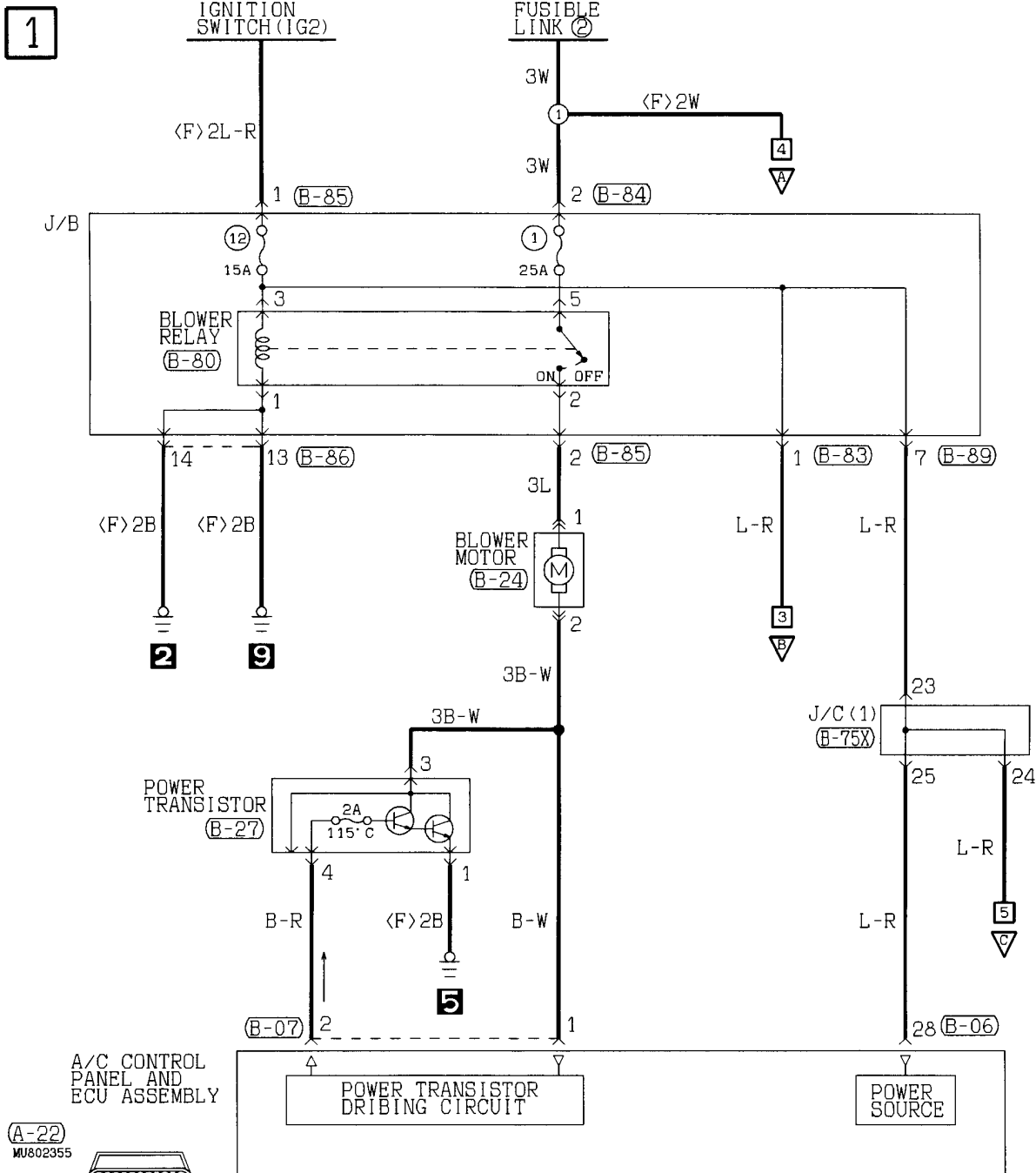

(A-22) MU802355

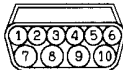

(A-69) MU802645

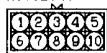

(A-80)



(B-06) (MU801584)

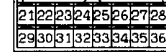

(B-07) (MU801585)

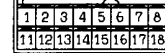

(B-16)

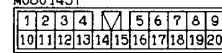

(B-19) (MU803773)

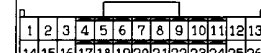

(B-85)



(B-86)

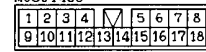

(B-88)

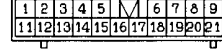

(B-89)

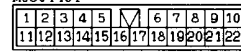

(B-102) (MU803782)

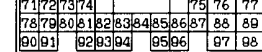

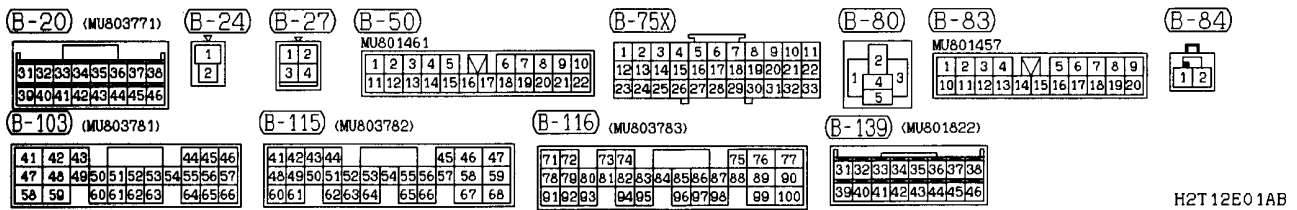
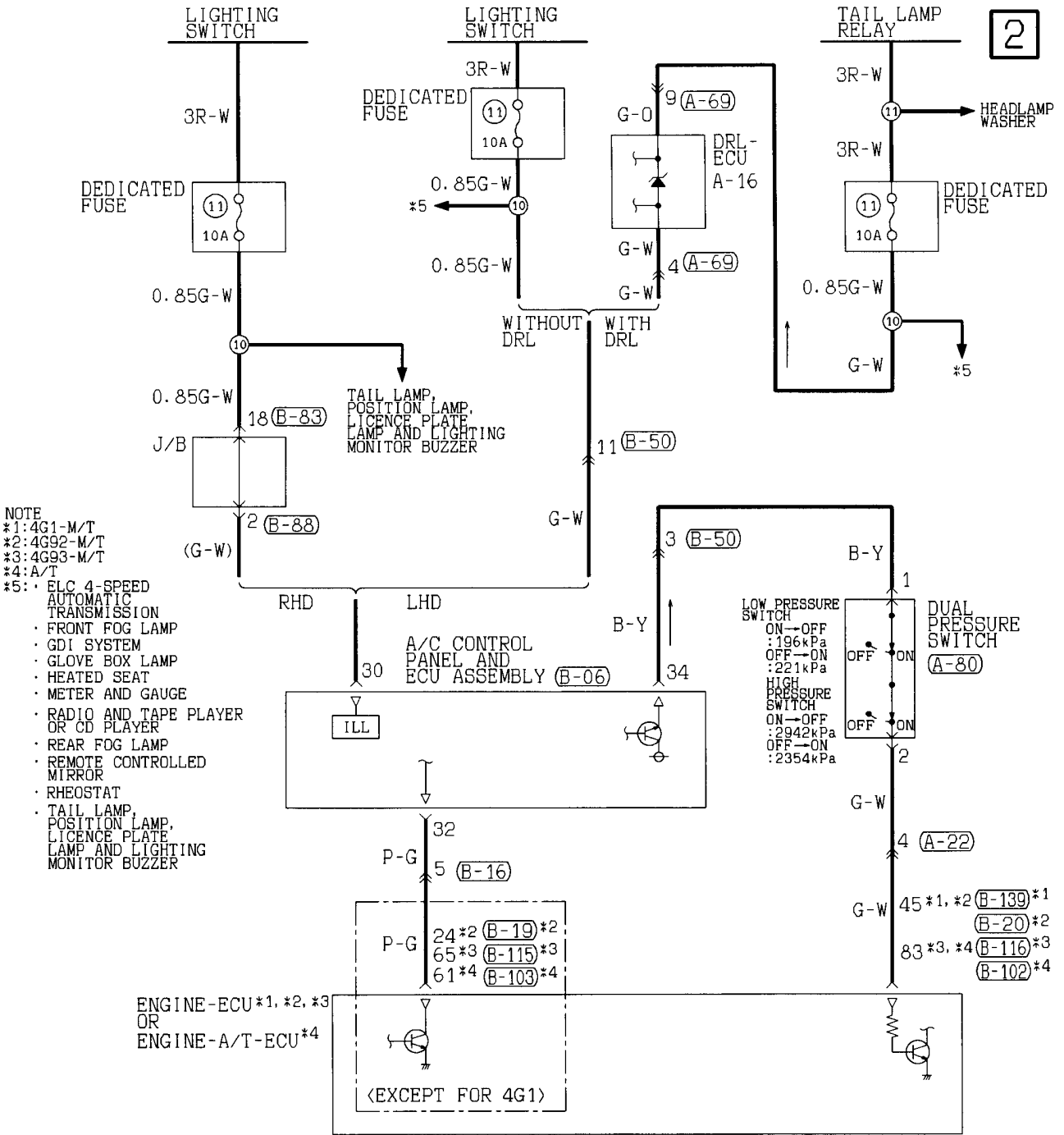

AUTOMATIC AIR CONDITIONER <Petrol-powered vehicles> (CONTINUED)

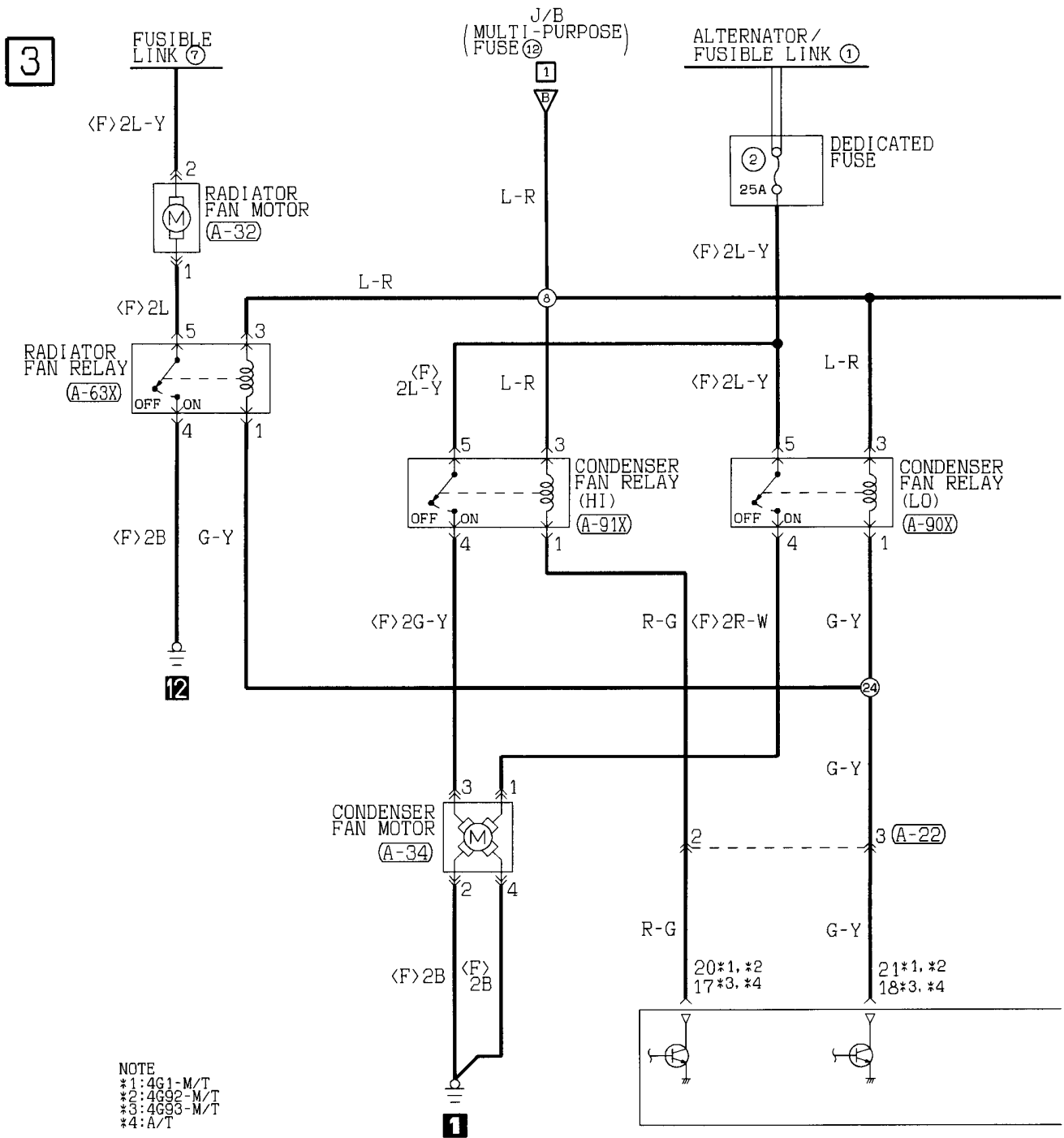

(A-22) MU802355

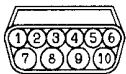

(A-32) MU802601



(A-34) MU802665



(A-63X)



(A-81) MU802653



(A-90X)



(A-91X)



(A-92X)



(B-19) (MU803773)

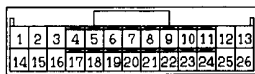

4

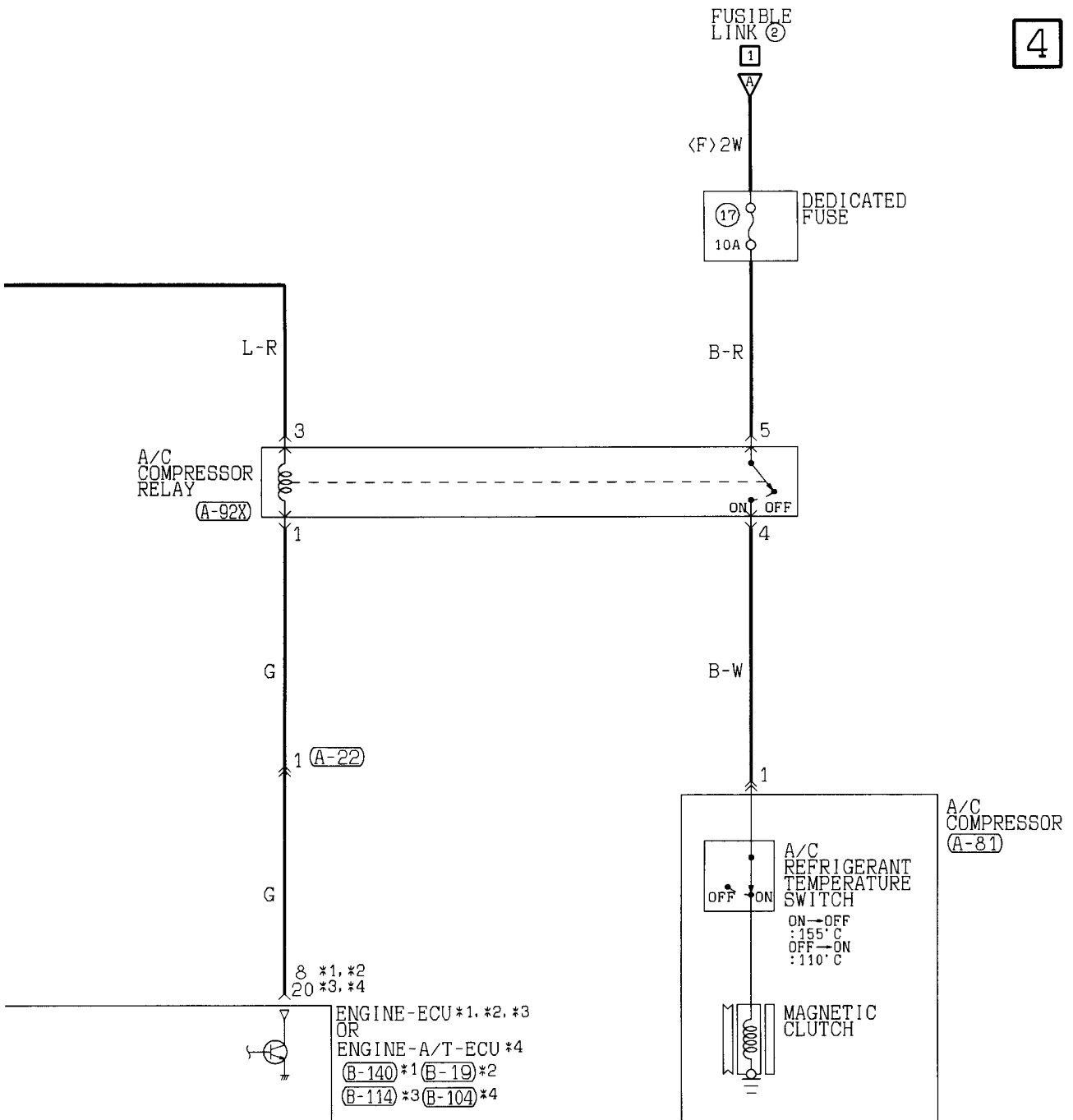

(B-104) (MU803784)

1	2	3	4	5	6	7	8
9	10	11	12	13	14	15	16
17	18	19	20	21	22	23	24
25	26	27	28	29	30	31	32
33	34	35					

(B-114) (MU803784)

1	2	3	4	5	6	7	8
9	10	11	12	13	14	15	16
17	18	19	20	21	22	23	24
25	26	27	28	29	30	31	32
33	34	35					

(B-140) (MU801824)

1	2	3	4	5	6	7	8
9	10	11	12	13	14	15	16
17	18	19	20	21	22	23	24
25	26						

Wire colour code
 B : Black LG : Light green G : Green L : Blue W : White Y : Yellow SB : Sky blue
 BR : Brown O : Orange GR : Gray R : Red P : Pink V : Violet

AUTOMATIC AIR CONDITIONER <Petrol-powered vehicles> (CONTINUED)

5

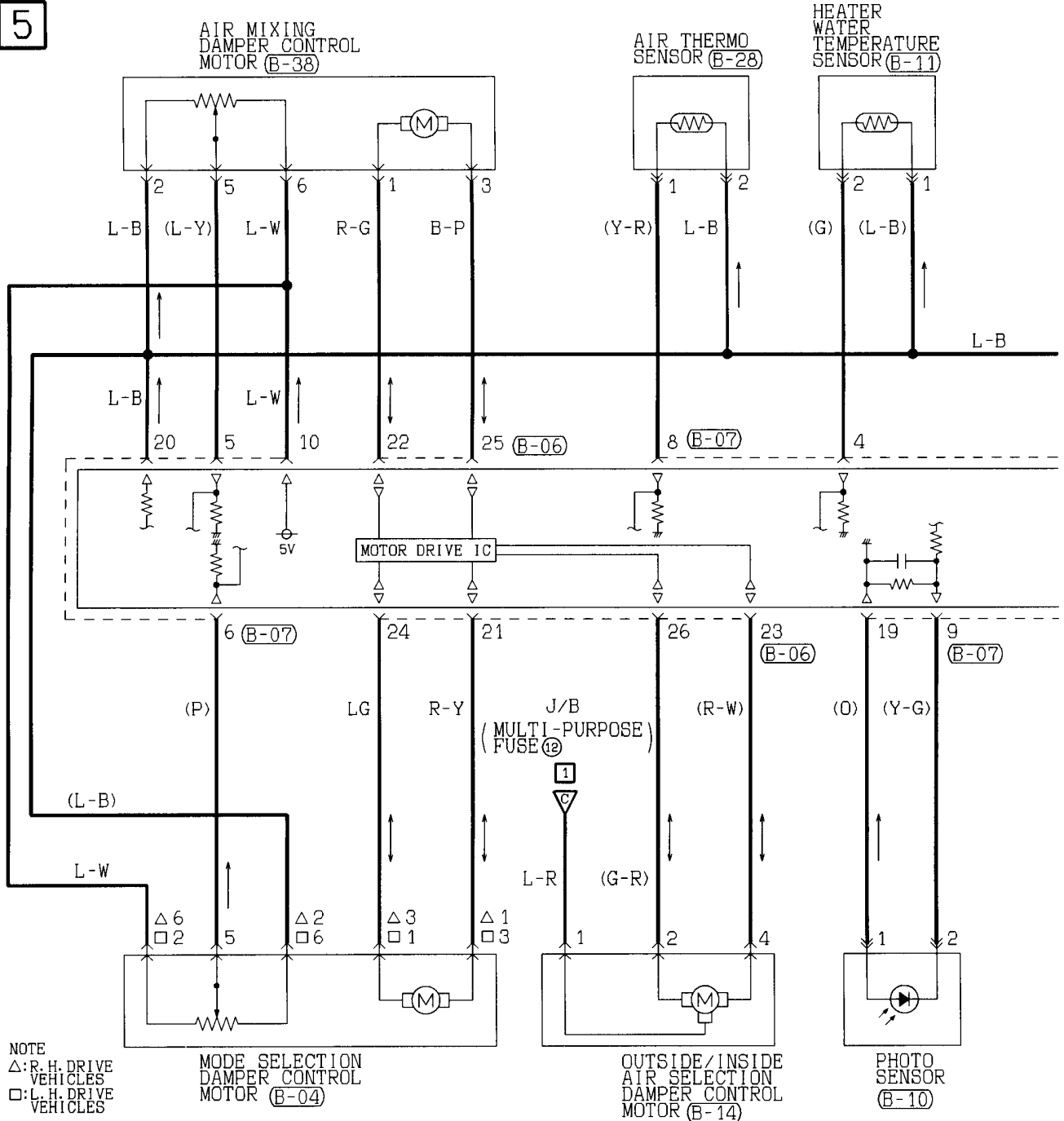

NOTE
 Δ: R. H. DRIVE VEHICLES
 □: L. H. DRIVE VEHICLES

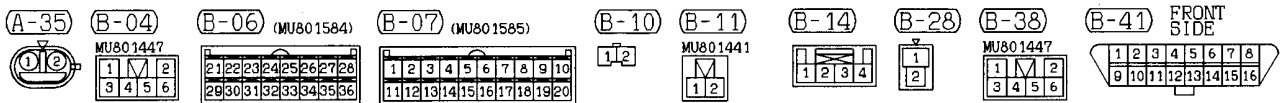

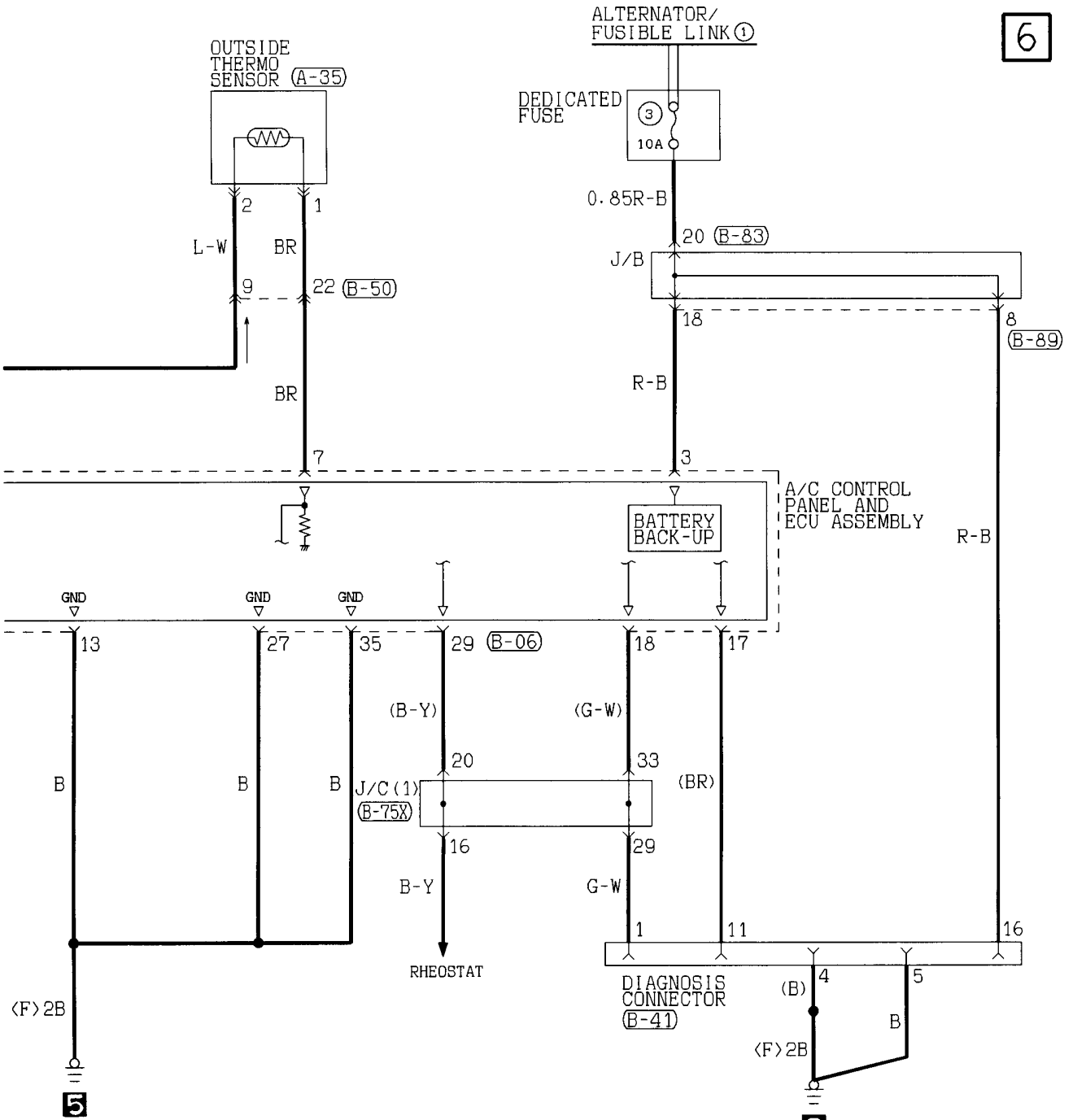

(B-50)

MU801461

1	2	3	4	5	6	7	8	9	10
11	12	13	14	15	16	17	18	19	20
21	22	23	24	25	26	27	28	29	30
31	32	33							

(B-75X)

MU801457

1	2	3	4	5	6	7	8	9	10
11	12	13	14	15	16	17	18	19	20
21	22	23	24	25	26	27	28	29	30
31	32	33							

(B-83)

MU801457

1	2	3	4	5	6	7	8	9	
10	11	12	13	14	15	16	17	18	19
20									

(B-89)

MU801461

1	2	3	4	5	6	7	8	9	10
11	12	13	14	15	16	17	18	19	20
21	22								

Wire colour code
 B : Black LG:Light green G :Green L :Blue W :White Y :Yellow SB:Sky blue
 BR:Brown O :Orange GR:Gray R :Red P :Pink V :Violet

AUTOMATIC AIR CONDITIONER <Petrol-powered vehicles> (CONTINUED)

7

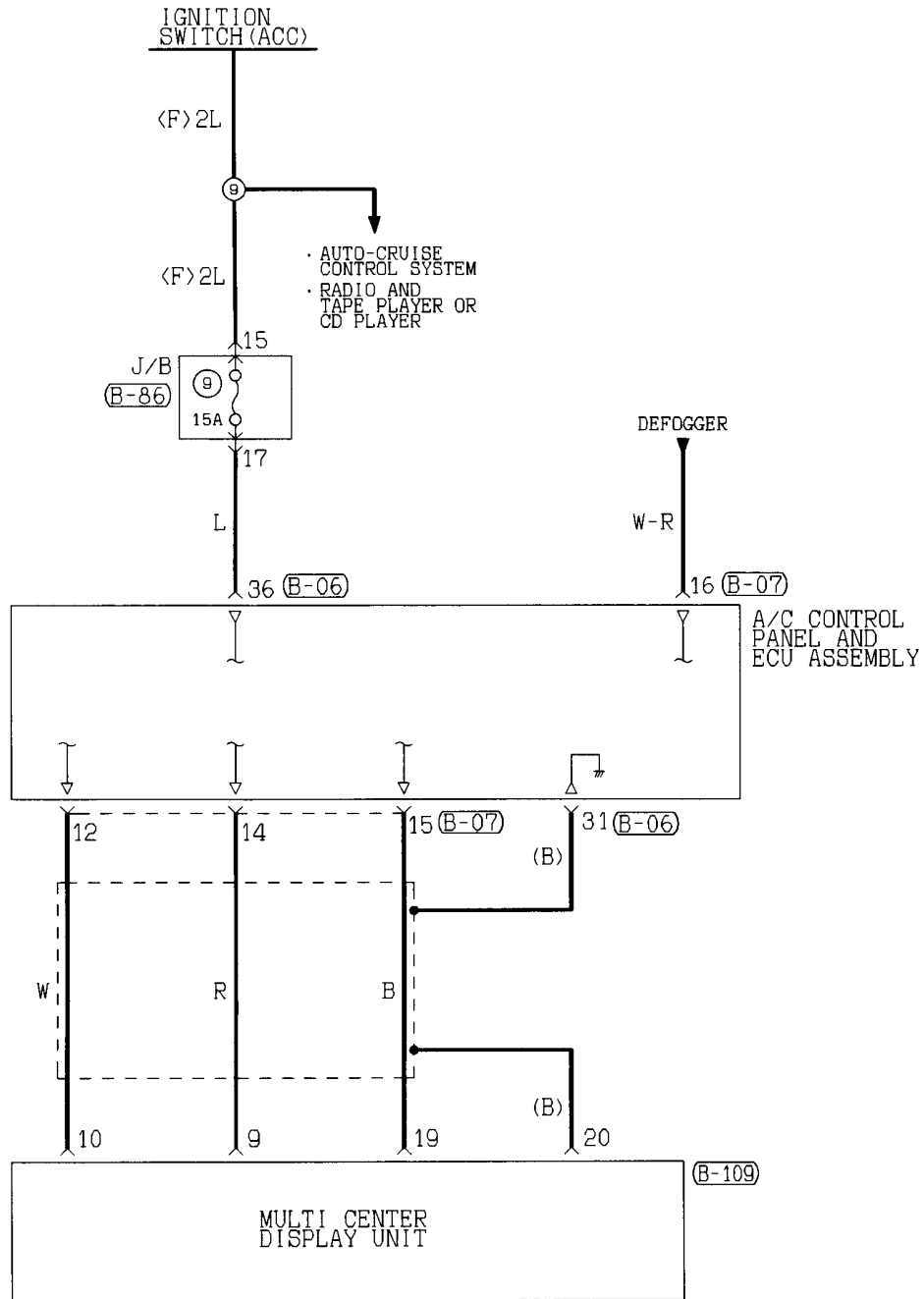

(B-06) (MU801584)

21	22	23	24	25	26	27	28
29	30	31	32	33	34	35	36

(B-07) (MU801585)

1	2	3	4	5	6	7	8	9	10
11	12	13	14	15	16	17	18	19	20

(B-86)

1	2	3	4	5	6	7	8		
9	10	11	12	13	14	15	16	17	18

(B-109) (MU801585)

1	2	3	4	5	6	7	8	9	10
11	12	13	14	15	16	17	18	19	20

Wire colour code
 B :Black LG:Light green G :Green L :Blue W :White Y :Yellow SB:Sky blue
 BR:Brown O :Orange GR:Gray R :Red P :Pink V :Violet

NOTES

MULTI CENTER DISPLAY

Petrol-powered vehicles

1

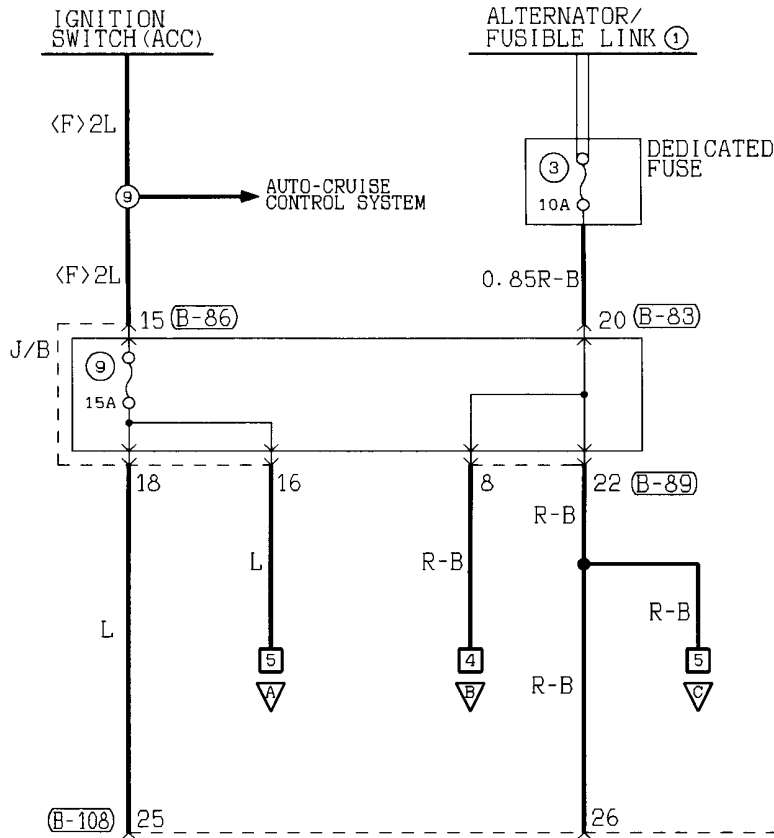

NOTE

- *: ELC 4-SPEED AUTOMATIC TRANSMISSION
- FRONT FOG LAMP
- GDI SYSTEM
- GLOVE BOX LAMP
- HEATED SEAT
- HEATER
- MANUAL AIR CONDITIONER
- METER AND GAUGE
- RADIO AND TAPE PLAYER OR CD PLAYER
- REAR FOG LAMP
- REMOTE CONTROLLED MIRROR
- RHEOSTAT
- TAIL LAMP, POSITION LAMP, LICENCE PLATE LAMP AND LIGHTING MONITOR BUZZER

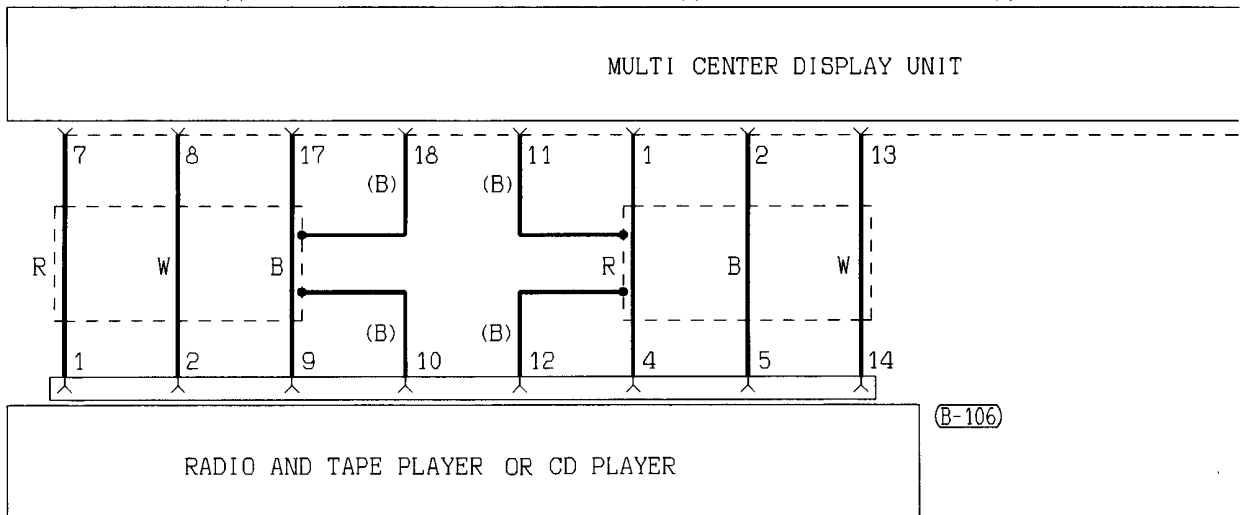
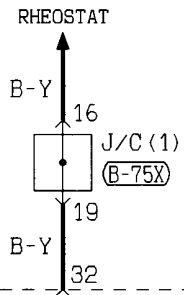

(B-106)

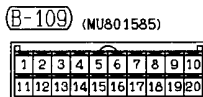
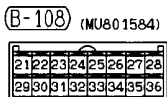
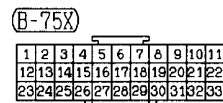
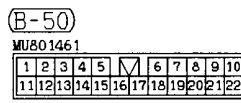
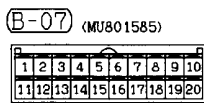
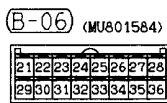
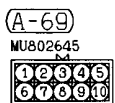

2

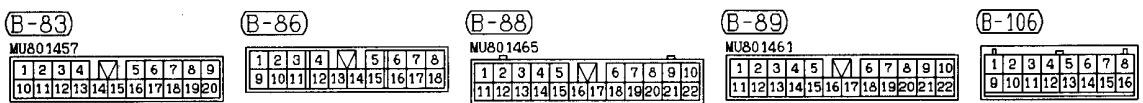
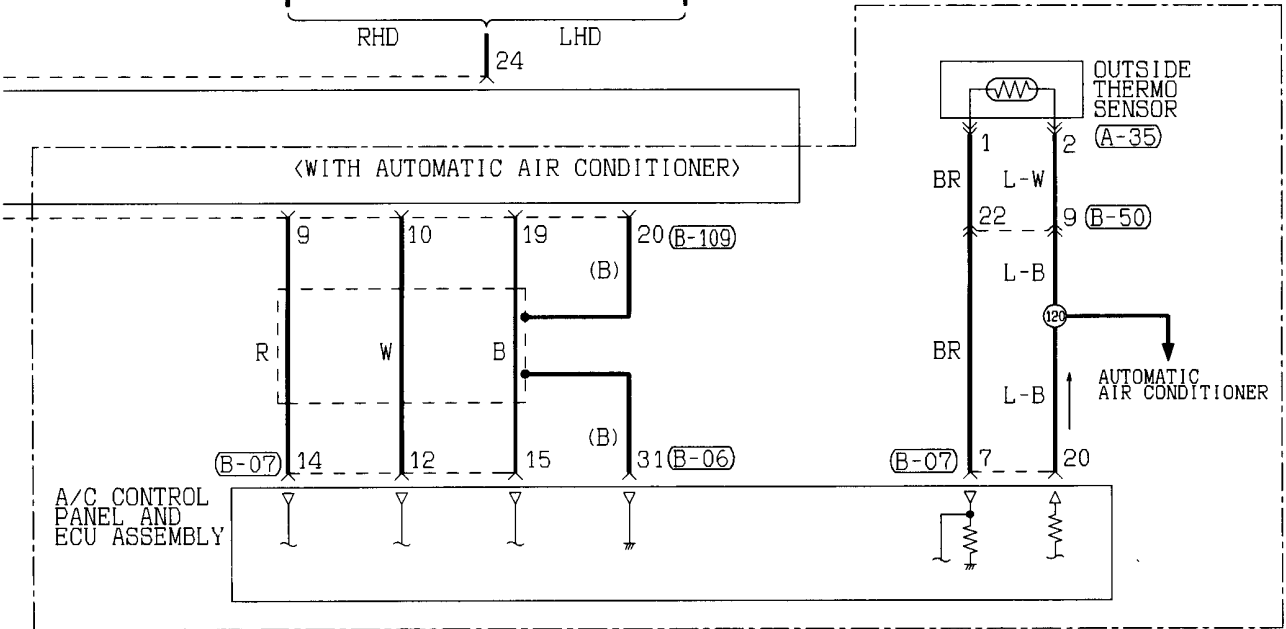
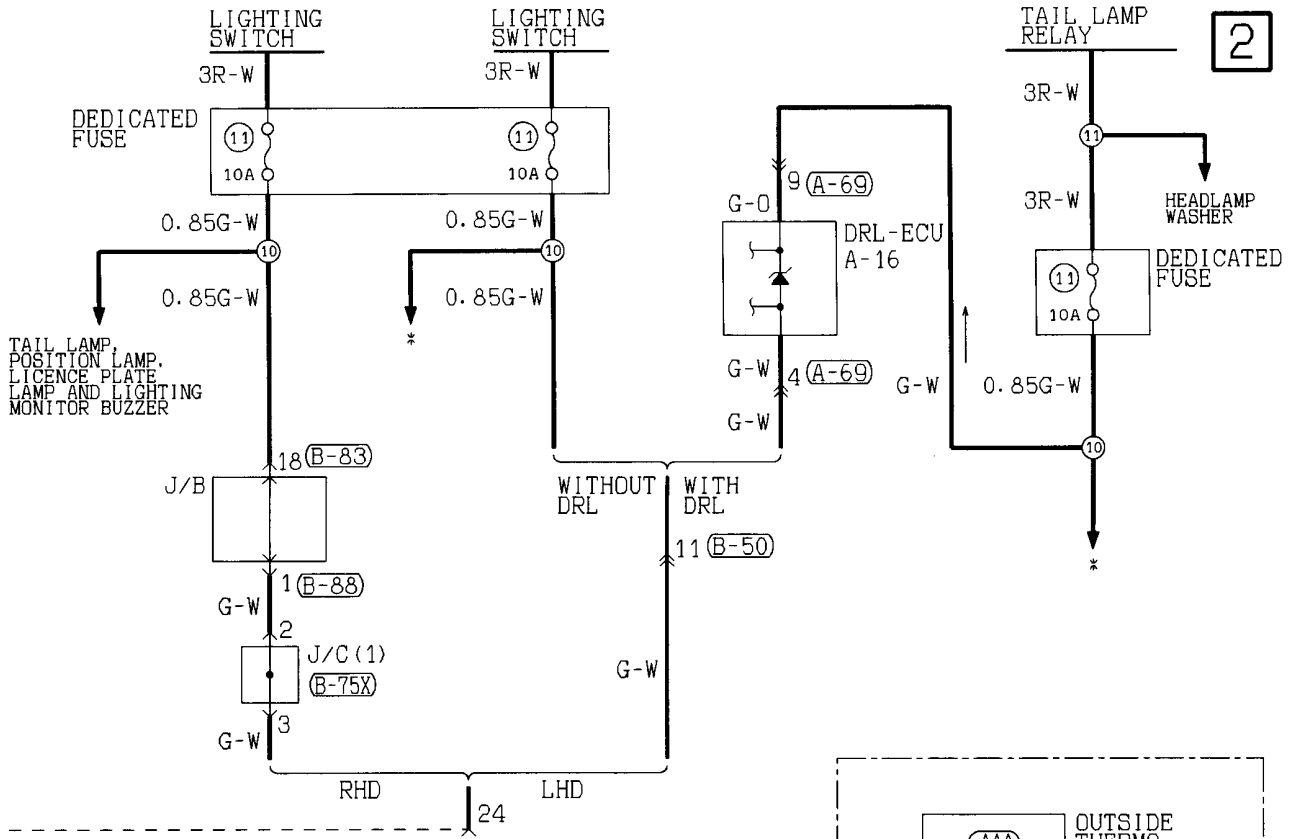

Wire colour code
 B:Black LG:Light green G:Green L:Blue W:White Y:Yellow SB:Sky blue
 BR:Brown O:Orange GR:Gray R:Red P:Pink V:Violet

MULTI CENTER DISPLAY <Petrol-powered vehicles> (CONTINUED)

3

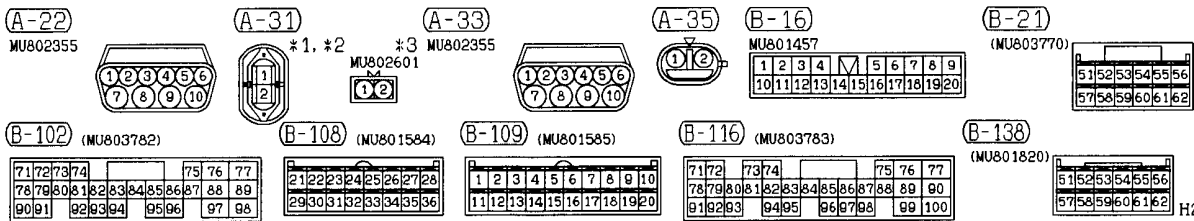
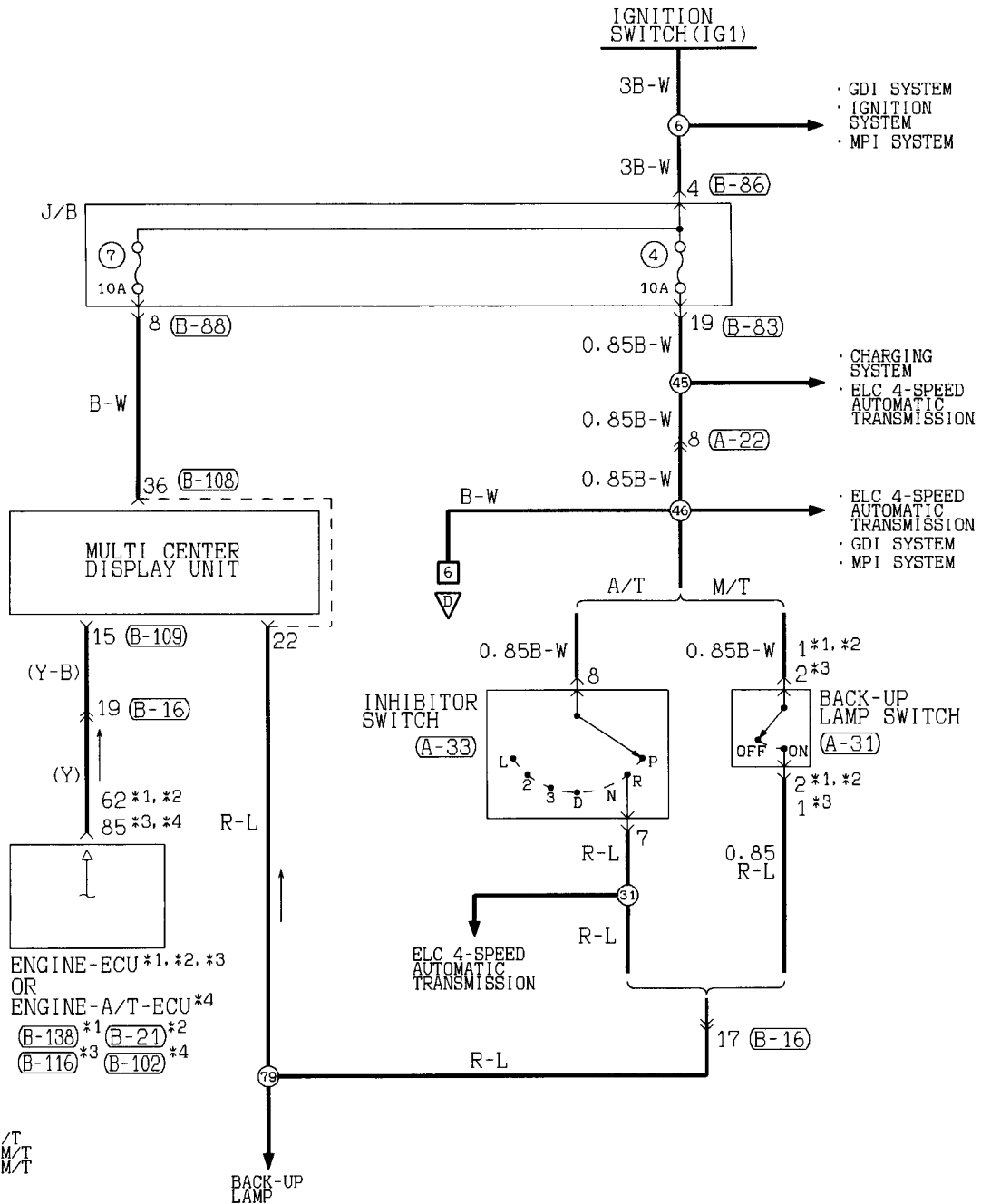

4

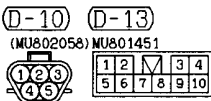
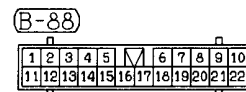
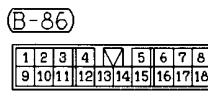
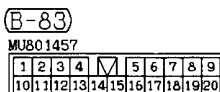
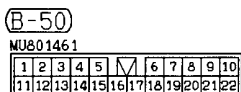
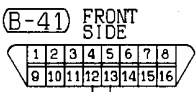
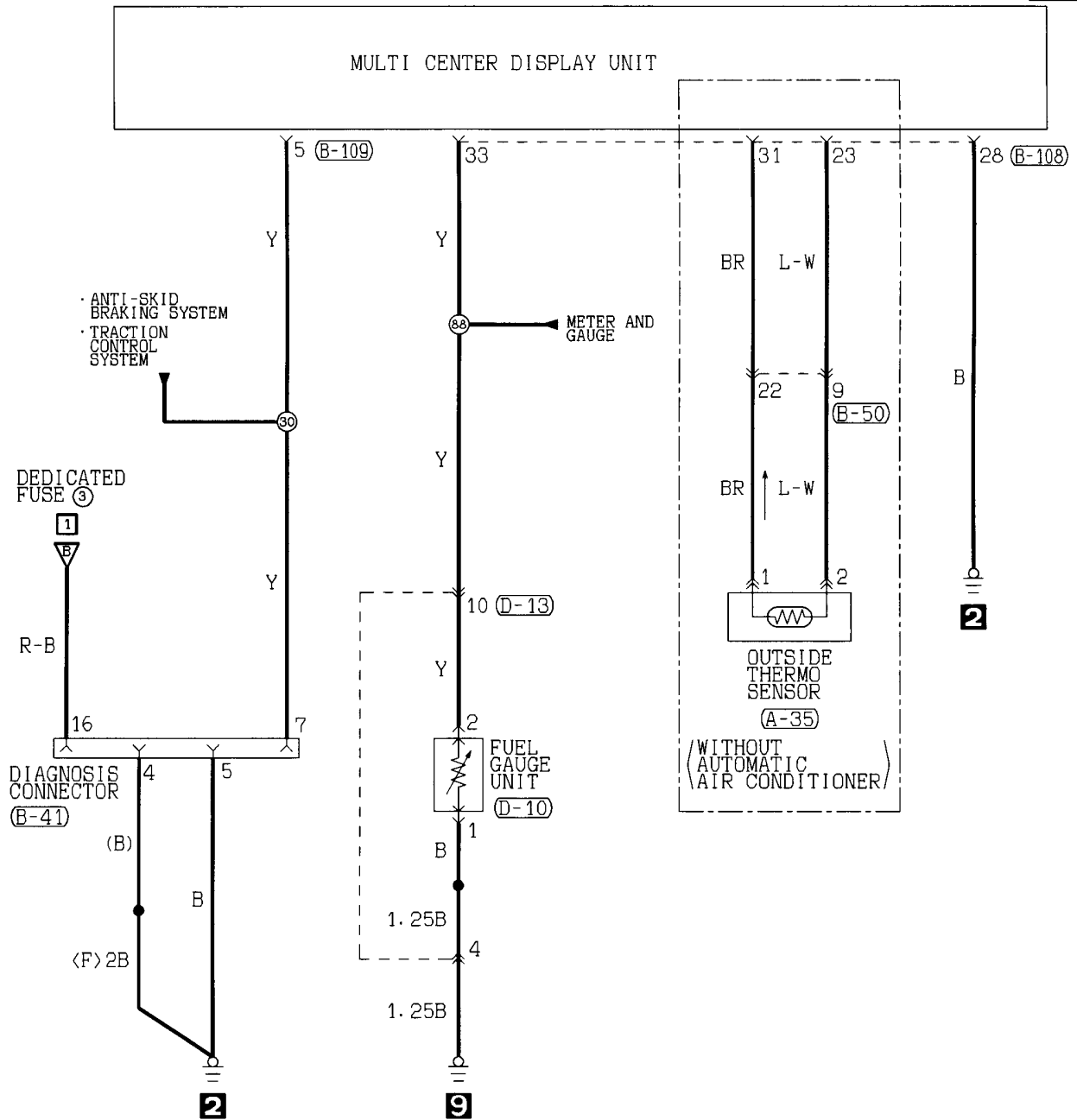

Wire colour code
 B : Black LG: Light green G : Green L : Blue W : White Y : Yellow SB: Sky blue
 BR: Brown O : Orange GR: Gray R : Red P : Pink V : Violet

MULTI CENTER DISPLAY <Petrol-powered vehicles> (CONTINUED)

5

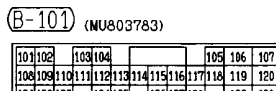
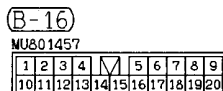
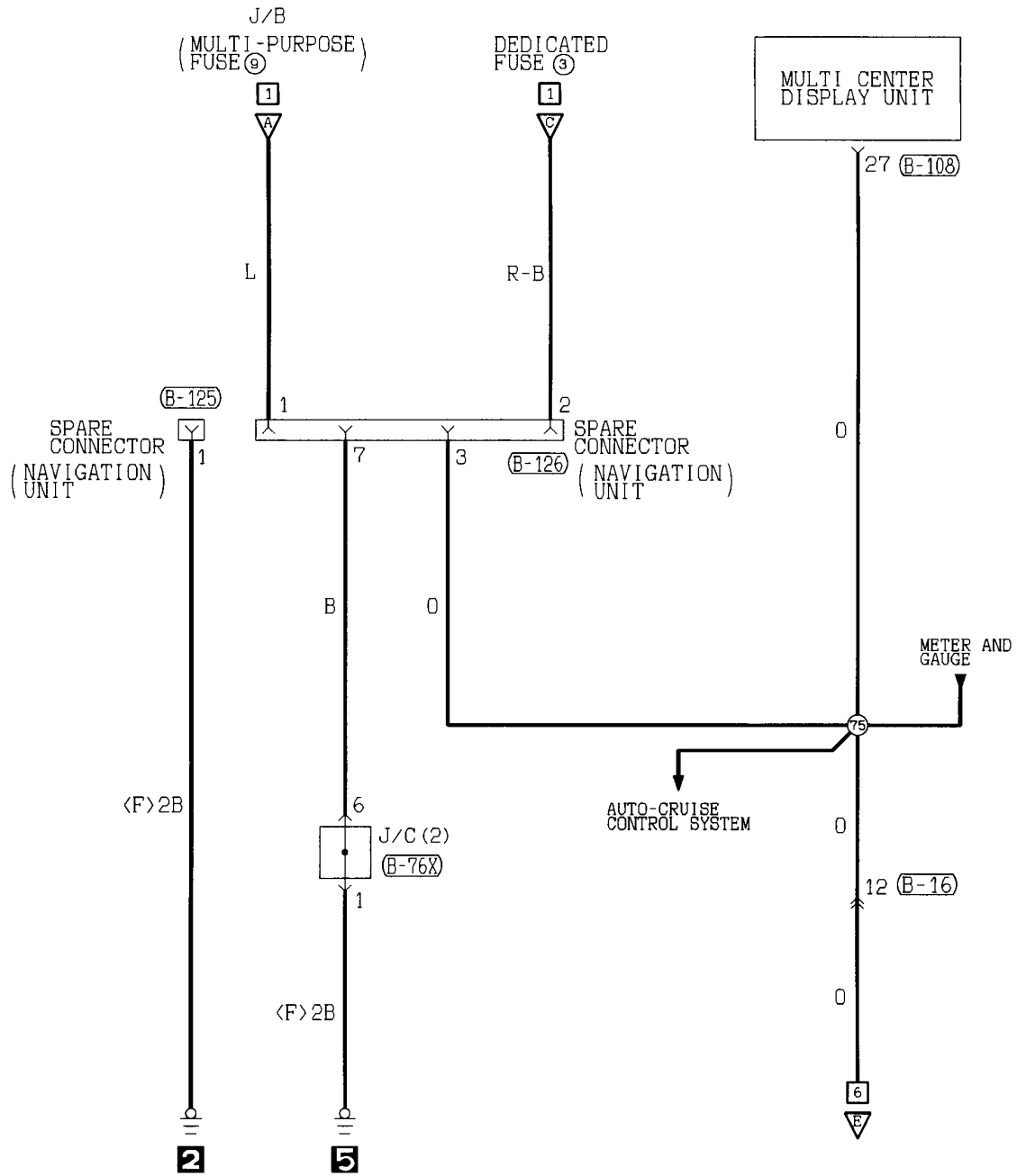

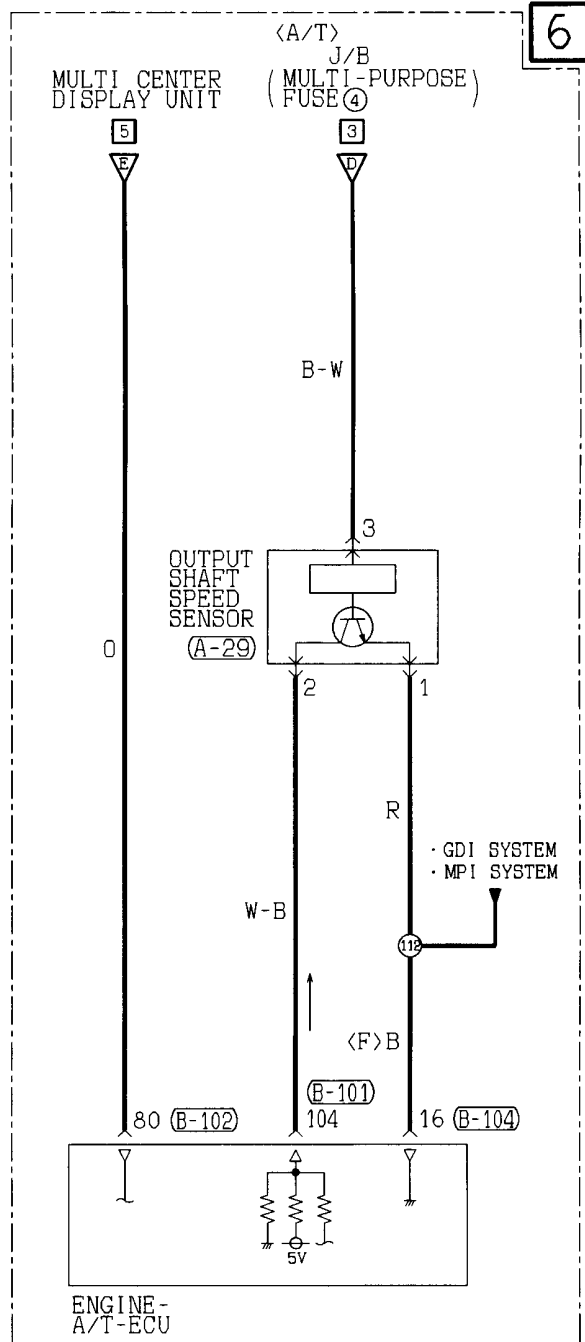
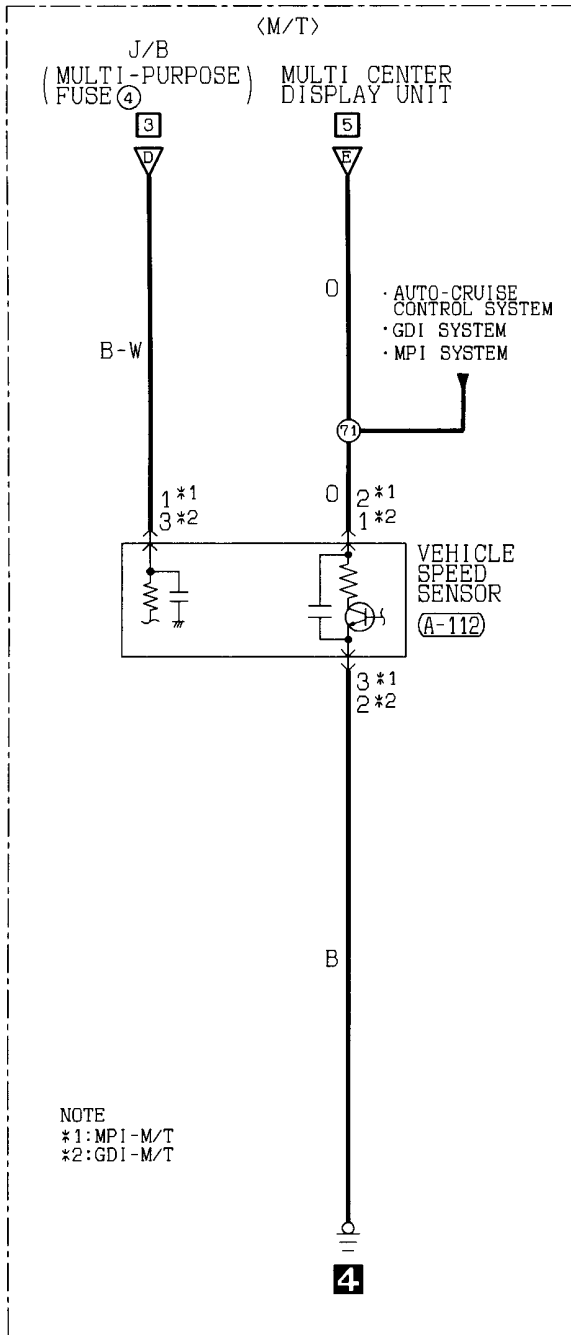

(B-104) (MU803784)

1	2	3	4	5	6	7	8
9	10	11	12	13	14	15	16
17	18	19	20	21	22	23	24
25	26	27	28	29	30	31	32
33	34	35					

(B-108) (MU801584)

1	2	3	4	5	6	7	8
9	10	11	12	13	14	15	16

(B-125)

1

(B-126)

1	2	3	4	5	6
7	8	9	10	11	12

Wire colour code
 B : Black LG : Light green G : Green L : Blue W : White Y : Yellow SB : Sky blue
 BR : Brown O : Orange GR : Gray R : Red P : Pink V : Violet

IMMOBILIZER SYSTEM

Petrol-powered vehicles

1

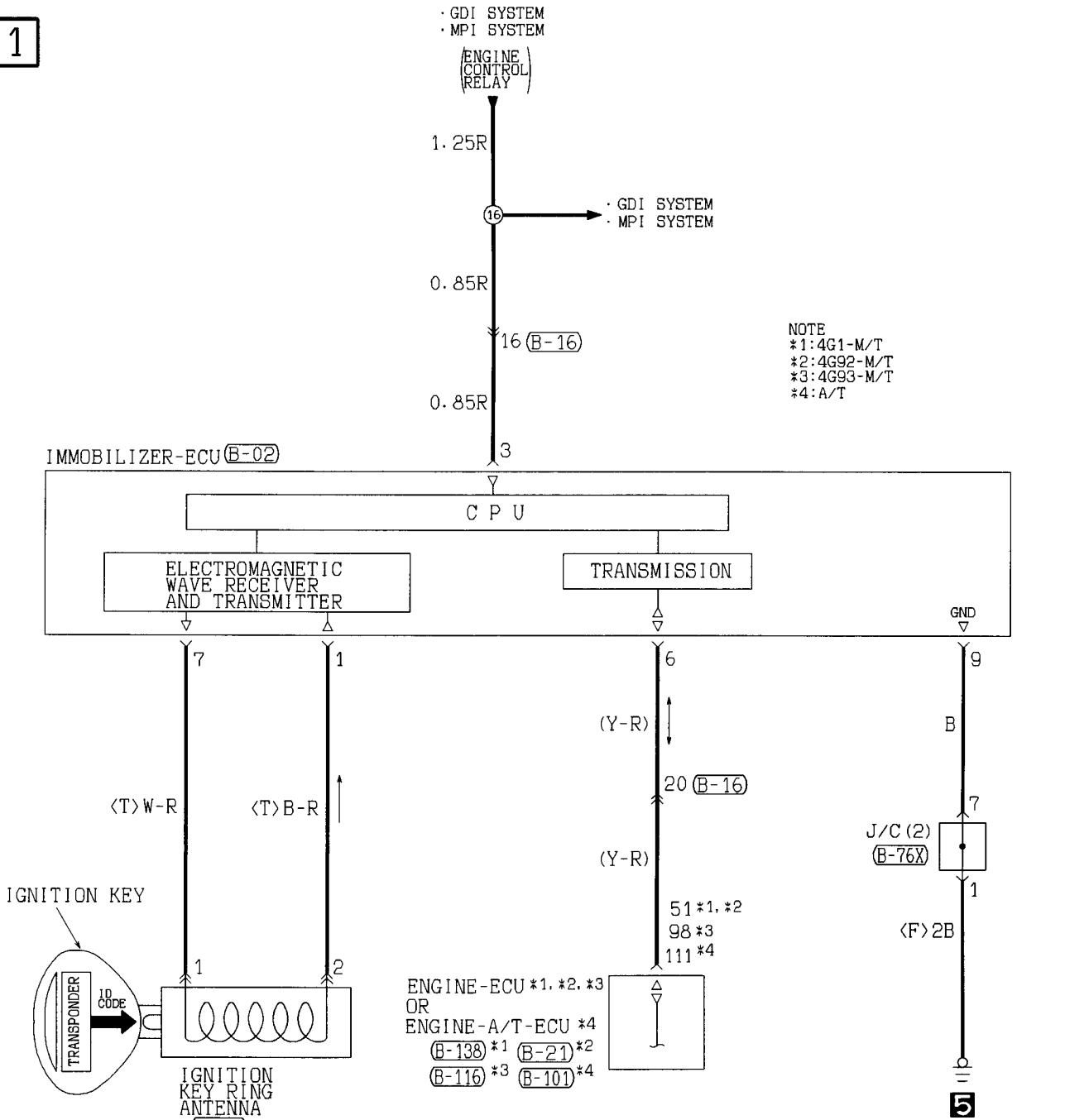

NOTE
*1: 4G1-M/T
*2: 4G92-M/T
*3: 4G93-M/T
*4: A/T

(B-02) (MU801583)

1	2	3	4	5	6
7	8	9	10	11	12

(B-16) (MU801457)

1	2	3	4	5	6	7	8	9		
10	11	12	13	14	15	16	17	18	19	20

(B-21) (MU803770)

51	52	53	54	55	56
57	58	59	60	61	62

(B-57) (MU801541)

1	2
---	---

(B-76X)

1	2	3	4	5	6	7	8	9	10	11
12	13	14	15	16	17	18	19	20	21	22
23	24	25	26	27	28	29	30	31	32	33

(B-101) (MU803783)

101	102	103	104	105	106	107						
108	109	110	111	112	113	114	115	116	117	118	119	120
121	122	123	124	125	126	127	128	129	130			

(B-116) (MU803783)

71	72	73	74	75	76	77						
78	79	80	81	82	83	84	85	86	87	88	89	90
91	92	93	94	95	96	97	98	99	100			

(B-138) (MU801820)

51	52	53	54	55	56
57	58	59	60	61	62

Wire colour code
 B : Black LG : Light green G : Green L : Blue
 BR : Brown O : Orange GR : Gray R : Red
 W : White SB : Sky blue P : Pink Y : Yellow
 V : Violet